



# ***BAE Bladder Accumulators***

*For working pressures up to 330 bar*

*Catalogue HY07-1235/UK  
February 2004*



**Introduction**

**Bladder Accumulators**

Liquids are practically incompressible and therefore cannot be used directly for storing energy. Hydro-pneumatic accumulators use the differing compressibility of liquid and gaseous media to enable energy to be stored in liquids under pressure.

Parker's hydro-pneumatic bladder accumulators provide a means of regulating the performance of a hydraulic system. Their simple, compact, design ensures dependable performance, maximum efficiency and long service life.

**Why use a Bladder Accumulator?**

- stores energy under pressure
- damps out pump pulsation and flow fluctuations
- improves system efficiency
- supplements pump delivery
- supplies power in emergency
- absorbs hydraulic shocks
- compensates for pressure changes in cases of thermal stress
- very contaminant tolerant
- suitable for use with low-lubricity fluids
- fast response times
- Safety – cannot disassemble under pressure

**Technical Data**

Standard volumes	1 – 50 litres
Operating pressure	Up to 330 bar, with $p_2 < 4 \times p_1$ where $p_1$ = minimum working pressure and $p_2$ = maximum working pressure
Precharge pressure	
– energy storage	90% of minimum working pressure
– pulsation dampening	60% of maximum working pressure
– shock suppression	60% of maximum pump pressure
Std. temperature range	Shell and ports: -40°C to +80°C Bladder and seals: -15°C to +80°C For use at other temperatures, please consult factory.
Fluid type	Mineral oil (standard compounds)

**Flow Rate** The maximum values listed in the selection table only apply in the case of vertical installation (fluid port facing downwards).

**Positioning** From vertical (fluid port downwards) to horizontal. Note that a minimum clearance of 200mm must be left above the gas valve for mounting the charging and gauging assembly – see page 5.

**Contents**

Technical Data	2
Design Features and Benefits	3
Models, Capacities and Dimensions	3
Repair Kits and Parts List	4
Bladder Compounds	5
Charging and Gauging Assemblies	5
Fluid Port Adapters	5
Mounting Accessories	6
How to Order	7

**Page**

**Index**

Approvals	3
Bladder Compounds	5
Charging and Gauging Assemblies	5
Dimensions	3
Features and Benefits	3
Flow Rates	3
Fluid Port Adapters	5
Model Numbers	7
Mounting Accessories	6
Ordering	7
Parts List	4
Repair Kits	4
Technical Data	2

**Page**

**Parker Hannifin Corporation . . .**

is a world leader in the manufacture of components and systems for motion control. Parker has more than 800 product lines for hydraulic, pneumatic and electro-mechanical applications in some 1200 industrial and aerospace markets. With over 45,000 employees and some 210 manufacturing plants and administrative offices around the world, Parker provides its customers with technical excellence and first class customer service. Parker Hannifin's Cylinder Division is

the world's largest supplier of hydraulic actuators and accumulators for industrial applications.

Catalogues describing our standard products are available from your nearest Parker sales office – please see the rear cover of this catalogue for addresses. Where an application demands a non-standard approach, special products can be designed to order – our engineers will be pleased to advise.



**Design Features and Benefits**

**1 Approvals**

Parker's BAE bladder accumulators are built to meet the requirements of the European Pressure Directive (PED) 97/23/EC. Bladder accumulators are marked with the CE logo and supplied with a declaration of conformity. Hydraulic accumulators fulfil the safety requirements for all member states of the European Union, as well as Iceland, Liechtenstein, Norway and Switzerland.

**2 Shell**

Parker's bladder accumulator shells are made from seamless chrome-molybdenum alloy steel with forged ends, for maximum strength. The standard shell is suitable for use at operating temperatures down to -40°C.

**3 Bladder**

The absence of dynamic sealing surfaces makes bladder accumulators tolerant of contamination and particularly suitable for low-lubricity fluids. Specially formulated for low permeability, Parker's bladders retain their high performance under a wide range of operating conditions including closed loop operation. Optional bladder compounds are available to suit all common fluids and operating temperatures.

**4 Gas Valve**

Accurate precharging of a bladder accumulator is the key to long and reliable service life. All Parker's bladder accumulators feature a robust gas valve, which is readily accessible for maintenance purposes. A charging and gauging assembly, described on page 5, allows precharging and monitoring to be carried out quickly and easily.

**5 Fluids and Fluid Ports**

Parker's bladder accumulators are supplied as standard for use with hydraulic mineral oil. They are also available for use with other media, such as bio-degradable hydraulic fluids, non-inflammable liquids, emulsions, etc. Fluid ports are made from high-strength alloy steel, for maximum durability. BSPP ports are fitted as standard. Other port styles are available.

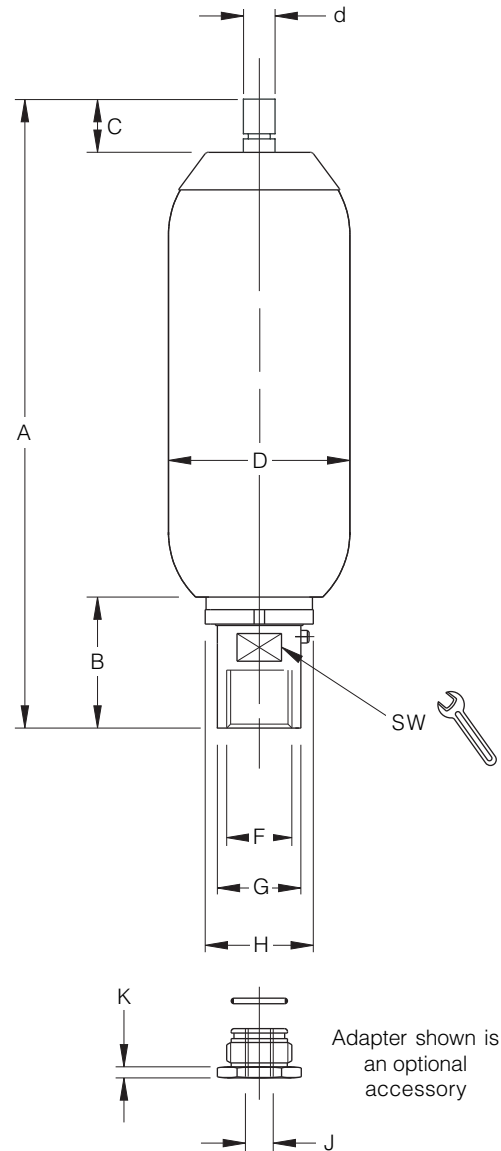

**Models, Capacities and Dimensions**

Model	Volume Litres	Mass Kg	Max flow l/min <sup>1</sup>	A max	B max	C max	ØD	Ød	F	ØG	ØH	SW	J	K
BAE01	1	5	240	305	50	55	115	36	G <sup>3</sup> / <sub>4</sub>	35	51	32	G <sup>3</sup> / <sub>8</sub>	8
BAE02	2.4	10	450	535	67	55	115	36	G1 <sup>1</sup> / <sub>4</sub>	53	75	50	G <sup>3</sup> / <sub>4</sub>	10
BAE04	3.7	13.5	450	417	67	55	170	36	G1 <sup>1</sup> / <sub>4</sub>	53	75	50	G <sup>3</sup> / <sub>4</sub>	10
BAE06	6.0	17.8	450	540	67	55	170	36	G1 <sup>1</sup> / <sub>4</sub>	53	75	50	G <sup>3</sup> / <sub>4</sub>	10
BAE10	9.2	29.5	900	559	93	51	223	36	G2	76	101	73	G1	13
BAE20	17.8	46	900	874	93	51	223	36	G2	76	101	73	G1	13
BAE24	22.5	53	900	1009	93	51	223	36	G2	76	101	73	G1	13
BAE32	34.6	73	900	1394	93	51	223	36	G2	76	101	73	G1	13
BAE50	50	101	900	1938	93	85	223	75	G2	76	101	73	G1	13

**Notes**

<sup>1</sup> A minimum liquid volume (10% of V<sub>0</sub>) must be maintained inside the accumulator.

All dimensions are subject to manufacturing tolerances. All dimensions are in millimetres unless otherwise stated.

In line with our policy of continuing product improvement, specifications in this catalogue are subject to change without notice.

**Spare Parts and Repair Kits**

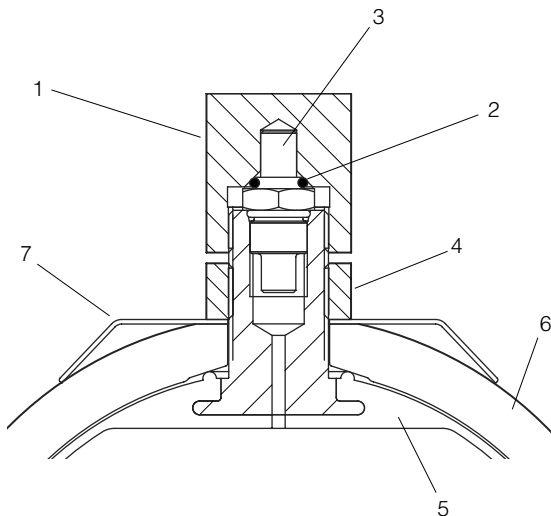

**Gas Valve Assembly**

**Parts List (All Models)**

- 1\* Protective cap
- 2\* O-ring – protective cap
- 3\* Gas valve
- 4\* Gas valve lock nut
- 5\* Bladder
- 6 Shell
- 7 Identification plate
- 8 Hydraulic port assembly
- 9\* Anti-extrusion ring moulding
- 10 Port spacer
- 11\* O-ring – hydraulic port
- 12\* O-ring back-up washer
- 13 Fluid port lock nut
- 14\* Bleed plug
- 15\* Sealing washer for bleed plug

\* – included in repair kit

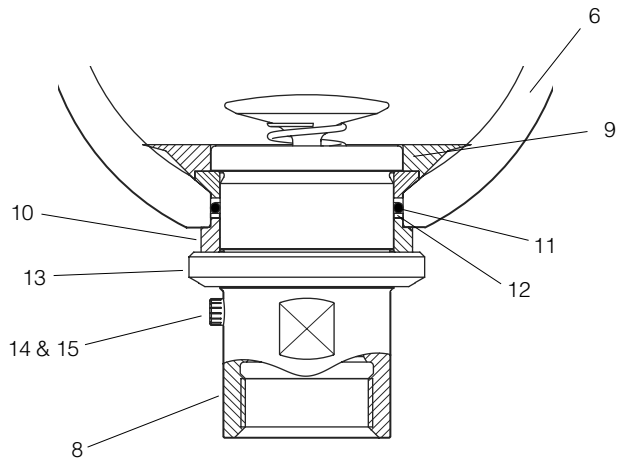

**Fluid Port Assembly – All Models**

**Repair Kits**

Repair kits are available for all accumulator models. When ordering repair kits, please supply the complete model number from the identification plate and specify the fluid type and the temperature at which the accumulator is to be used. The repair kit comprises those parts marked with an asterisk in the parts list. For a full description of the compound abbreviations, see 'Bladder Compounds' on page 5.

Model	Compound				
	NBR	IIR	FPM	EPDM	ECO
BAE01	BAE-BK01NBR	Consult Factory			
BAE02	BAE-BK02NBR				
BAE04	BAE-BK04NBR				
BAE06	BAE-BK06NBR				
BAE10	BAE-BK10NBR				
BAE20	BAE-BK20NBR				
BAE24	BAE-BK24NBR				
BAE32	BAE-BK32NBR				
BAE50	BAE-BK50NBR				

### Bladder Compounds

Parker offers bladders moulded from a variety of compounds, to suit a wide range of fluids and operating temperatures. Unless ordered specially, a Group 1 (nitrile) bladder will be supplied. The table lists the compounds in which bladders are available, their recommended operating temperature ranges,

and the types of fluids with which the different materials are generally compatible. Note that temperature ranges may vary depending on the fluid used in the hydraulic system. If in doubt, contact the factory with details of the application.

Group	Bladder Compound	Fluid Medium	Temperature Range
1	Nitrile (NBR)	General purpose, mineral oil-based fluids	-15°C to +80°C
		HFA and HFB fluids <sup>1</sup>	+5°C to + 55°C
		HFC fluids <sup>1</sup>	-15°C to +60°C
2	Low Temperature Nitrile (LT NBR)	Mineral oil-based fluids	-35°C to +75 °C
3	Butyl (IIR)	Most phosphate ester and some synthetic fluids	-15°C to +80°C
5	Fluorocarbon Elastomer (FPM)	High temperature and/or synthetic fluids	-20°C to +100°C <sup>2</sup>
7	Ethylene Propylene Diene (EPDM)	Phosphate ester-based fluids and water	-40°C to +80°C <sup>3</sup>
9	Epichlorohydrine (ECO)	General purpose fluids with enhanced low temperature performance	-32°C to +80°C <sup>3</sup>

<sup>1</sup> Check with fluid supplier that fluid is compatible with nitrile compounds

<sup>2</sup> For operating temperatures above 80°C, please consult the factory

<sup>3</sup> For operating temperatures below -20°C, please consult the factory

### Port Sizes

Fluid ports are made from high-strength alloy steel, for maximum durability. BSPP ports are fitted as standard. ISO 6149 and SAE ports are available on request.

Model	BSPP	ISO 6149-1	SAE-Thread	SAE Flange (ISO 6162)
BAE01	G <sup>3</sup> / <sub>4</sub>	M27x2	#12 1 <sup>1</sup> / <sub>16</sub> "-12	n/a
BAE02 - BAE06	G1 <sup>1</sup> / <sub>4</sub>	M42x2	#20 1 <sup>5</sup> / <sub>8</sub> "-12	1" 6000 psi Code 62
BAE10 - BAE50	G2	M60x2	#24 1 <sup>7</sup> / <sub>8</sub> "-12	1 <sup>1</sup> / <sub>2</sub> " 6000 psi Code 62

### Fluid Port Adapters

A range of adapters is available for use with Parker's bladder accumulators, to reduce the size of the fluid port. Adapters are supplied complete with a nitrile O-ring.

Model	Fluid Port Thread	Adapter Thread	Part No.
BAE01	G <sup>3</sup> / <sub>4</sub>	G <sup>3</sup> / <sub>8</sub>	BPA1
BAE02 - BAE06	G1 <sup>1</sup> / <sub>4</sub>	G <sup>3</sup> / <sub>4</sub>	BPA2
BAE10 - BAE50	G2	G1	BPA3

### Charging and Gauging Assembly

The charging and gauging assembly enables the user to charge Parker's bladder accumulators with nitrogen, and to test and alter the precharge pressure. It attaches to the accumulator's gas valve, and can be connected by hose to a standard commercial nitrogen bottle. Each kit contains:

- Test and filling apparatus incorporating gas valve key and bleed valve
- Filling hose, length 2.5m
- Protective case
- Gas valve adapters to fit all standard bladder accumulators
- 25 bar and 250 bar pressure gauges

Parker strongly recommends that the nitrogen bottle used should be fitted with a high pressure regulator.

Charging and Gauging Assembly with Adapter – All Models		
Territory	Gas Bottle Fitting	Part No.
UK	5/8 BSP (male)	UCA 02
France	W 21.7 x 1/14" (female)	UCA 04
Germany	W 24.32 x 1/14" (female)	UCA 01
Italy	W 21.7 x 1/14" (male)	UCA 05
US	0,960 x 1/14" (male)	UCA 03

**Accessories**

**Mounting Accessories**

Parker clamp and base brackets provide a simple and secure method of mounting the accumulator. The clamps and brackets are galvanised to resist damage from corrosion. Rubber inserts absorb vibration and resist deformation in high temperature environments.

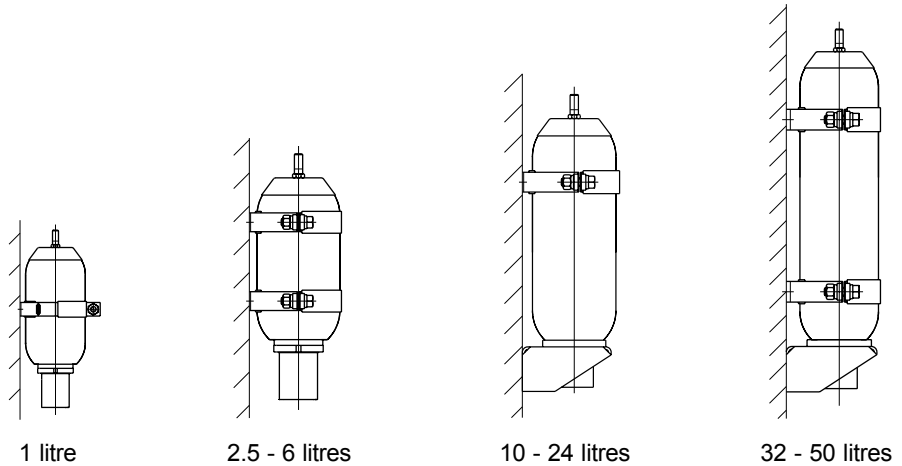

**Clamp Bracket Assembly**

Model	Nominal Volume (l)	Part No.	Quantity	See Figure	A	B	C	ØD	E	H	K	ØL	M
BAE01	1	CB1	1	1	138	100	159	114	-	73	30	9	14
BAE02	2.5												
BAE04	4	CB2	2	2	188	148	181	168	230	92	40	9	14
BAE06	6												
BAE10	10	CB3	1	3	270	216	241	226	290	123	40	15	21
BAE20	20												
BAE24	24												
BAE32	32												
BAE50	50												

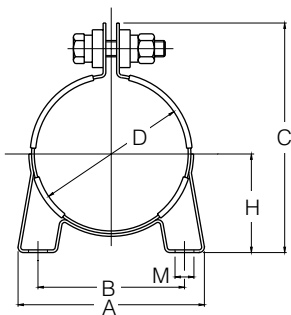

Fig. 1

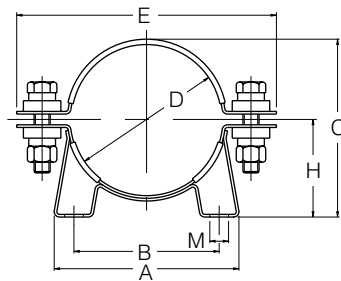
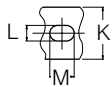

Fig. 2

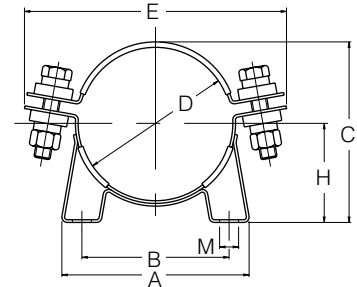
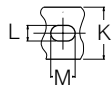
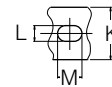
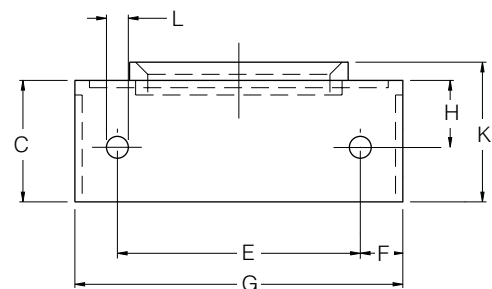
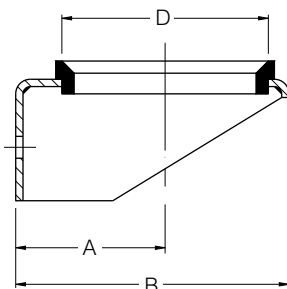

Fig. 3



**Base Bracket Assembly**

Model	Nominal Volume (l)	Part No.	A	B	C	D	E	F	G	H	K	L
BAE10 - BAE50	10 - 50	BB1	123	235	100	170	200	30	260	25	115	17



All dimensions are in mm unless otherwise stated

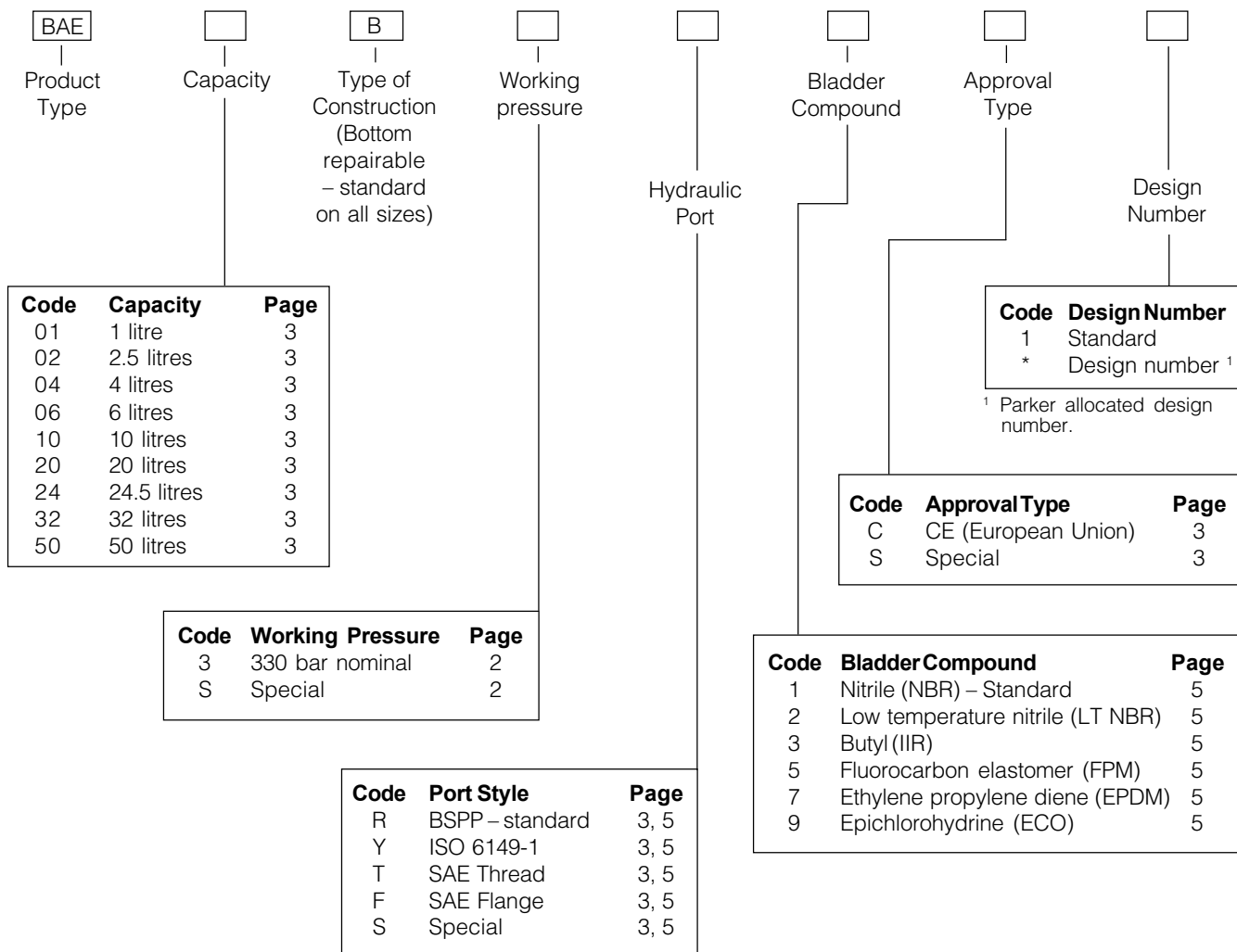

BAE Series bladder accumulators are supplied with a Declaration of Conformity in accordance with European Pressure Equipment Directive 97/23/EC, and with an operating manual and a drawing showing the main dimensions and materials.

# Hydraulics Group Sales Offices

## Europe

### Austria

#### Wiener Neustadt

Tel: +43 (0)2622 23501 970  
Fax: +43 (0)2622 23501 977

### Belgium

#### Nivelles

#### Parc Industriel Sud-Zone II

Tel: +32 (0)67 280 900  
Fax: +32 (0)67 280 999

### Czech Republic

#### Prague

Tel: +420 2 830 85 221  
Fax: +420 2 830 85 360

### Denmark

#### Ishøj

Tel: +45 4356 0400  
Fax: +45 4373 8431

### Finland

#### Vantaa

Tel: +358 (0)9 4767 31  
Fax: +358 (0)9 4767 3200

### France

#### Contamine-sur-Arve

Tel: +33 (0)450 25 80 25  
Fax: +33 (0)450 03 67 37

### Germany

#### Kaarst

Tel: +49 (0)2131 4016 0  
Fax: +49 (0)2131 4016 9199

### Hungary

#### Budapest

Tel: +36 (06)1 220 4155  
Fax: +36 (06)1 422 1525

### Ireland

#### Clonee

Tel: +353 (0)1 801 4010  
Fax: +353 (0)1 801 4132

### Italy

#### Corsico (MI)

Tel: +39 02 45 19 21  
Fax: +39 02 4 47 93 40

### The Netherlands

#### Oldenzaal

Tel: +31 (0)541 585000  
Fax: +31 (0)541 585459

### Norway

#### Ski

Tel: +47 64 91 10 00  
Fax: +47 64 91 10 90

### Poland

#### Warsaw

Tel: +48 (0)22 863 49 42  
Fax: +48 (0)22 863 49 44

### Portugal

#### Leca da Palmeira

Tel: +351 22 9997 360  
Fax: +351 22 9961 527

### Slovakia

#### Ref. Czech Republic

### Spain

#### Madrid

Tel: +34 91 675 73 00  
Fax: +34 91 675 77 11

### Sweden

#### Spånga

Tel: +46 (0)8 597 950 00  
Fax: +46 (0)8 597 951 10

### United Kingdom

#### Watford (industrial)

Tel: +44 (0)1923 492 000  
Fax: +44 (0)1923 256 059

#### Ossett (mobile)

Tel: +44 (0)1924 282 200  
Fax: +44 (0)1924 282 299

## International

### Australia

#### Castle Hill

Tel: +61 (0)2-9634 7777  
Fax: +61 (0)2-9899 6184

### Canada

#### Milton, Ontario

Tel: +1 905-693-3000  
Fax: +1 905-876-0788

### China

#### Beijing

Tel: +86 10 6561 0520  
Fax: +86 10 6561 0526

### Asia Pacific Group

#### Hong Kong, Kowloon

Tel: +852 2428 8008  
Fax: +852 2425 6896

### India

#### Mumbai

Tel: +91 22 7907081  
Fax: +91 22 7907080

### Japan

#### Tokyo

Tel: +(81) 3 6408 3900  
Fax: +(81) 3 5449 7201

### Latin America Group

#### Brazil

Tel: +55 12 3954-5100  
Fax: +55 12 3954-5266

### South Africa

#### Kempton Park

Tel: +27 (0)11-392 7280  
Fax: +27 (0)11-392 7213

### USA

#### Cleveland (industrial)

Tel: +1 216-896-3000  
Fax: +1 216-896-4031

#### Lincolnshire (mobile)

Tel: +1 847-821-1500  
Fax: +1 847-821-7600

**Parker Hannifin is the world's premier supplier of motion and control systems and solutions, with sales and manufacturing facilities throughout the world. For product information and details of your nearest Parker sales office, visit us at [www.parker.com](http://www.parker.com) or call free on 00800 2727 5374.**



Catalogue HY07-1235/3-UK  
2M 02/04 PD

© Copyright 2004  
Parker Hannifin Corporation  
All rights reserved.