

# RCG Remote Charging & Gauging Block

Safe, convenient gas pressure management for all Parker piston and bladder accumulators

## Introduction

Correctly maintained gas pressure in an accumulator protects system components and optimizes system performance. The RCG Remote Charging and Gauging Block enables the operator to monitor gas pressure in remote or inaccessible accumulators in a safe and convenient manner.

The RCG Block is designed for use with all Parker piston and bladder accumulators. It enables the operator to pre-charge a newly installed accumulator and to check and adjust the pre-charge of an existing unit, and is particularly valuable where access to the accumulator charge valve is restricted due to height or confined installation.

Initial filling of the gas pre-charge, and adjustment where necessary, is carried out using a UCA Charging and Gauging Assembly – see Bulletin HY07-1244-T/UK.

## Warning – use only with Nitrogen



All dimensions are in millimetres unless otherwise stated.

## Features, Advantages and Benefits

- Convenient monitoring and pressure adjustment helps maintain system at optimum performance
- Can be mounted in any accessible location, for greater operator safety
- Suitable for all piston and bladder accumulators up to 350 bar working pressure
- Steel construction ensures long, reliable service life
- Chromated surface guards against corrosion
- Steel gas valve cap protects against external impact

Figure 1 RCG Block – Dimensions

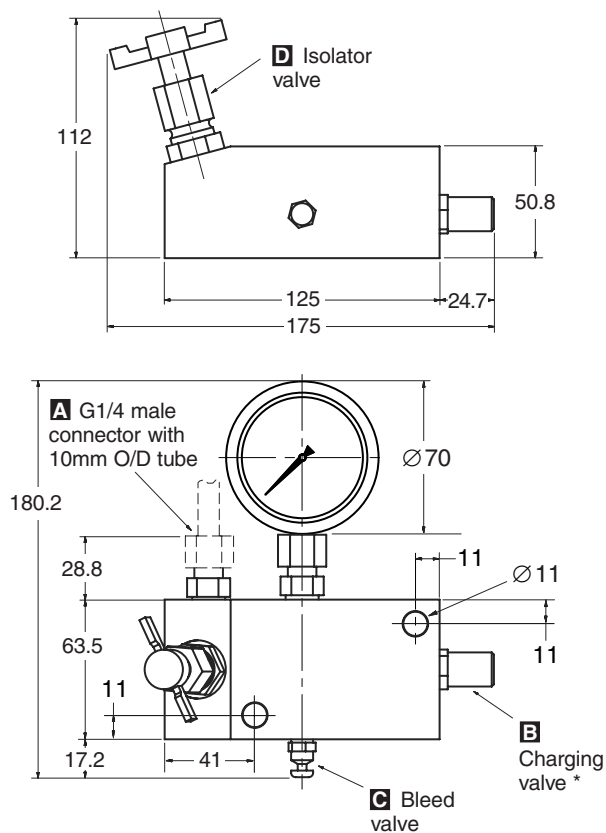

\* 200mm clearance should be allowed for connection of charging equipment

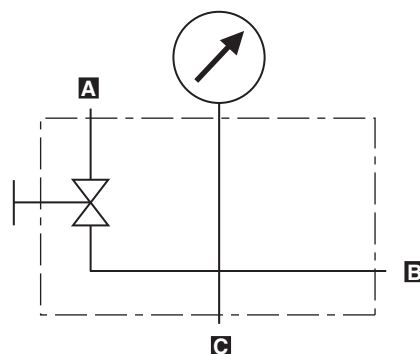

Figure 2 RCG Block – Circuit Diagram

**Construction and Specification**

Max. working pressure (block)	350 bar
Temperature range	-20°C to 80°C
Accumulator port (A)	G1/4
Gas valve	350 bar rated, cored type
Mass	3.4kg

**Preparation – Safe Practice****Never charge with air or oxygen**

Before working on any accumulator or associated equipment, read the operating instructions. If unavailable, please ask for a copy from your nearest Parker sales office.

A & AP Series Piston Accumulator Operating Instructions

– bulletin HY07-1240-T

BAE Series Bladder Accumulator Operating Instructions

– bulletin HY07-1235-T

UCA Series Charging and Gauging Kit

– bulletin HY07-1244-T

**Installation Fig. 1****Safety – Gas Pressure and Hydraulic Fluid**

The accumulator **must** be isolated from the hydraulic system and the fluid discharged completely. Once the fluid is discharged, all gas pressure from the accumulator must be discharged using the charging and gauging kit. **Do not** attempt to release gas pressure in the accumulator manually.

Remove the protective cap from the charging valve B and connect a UCA charging and gauging kit to the valve according to the instructions supplied with the kit. Discharge the gas side of the accumulator, then remove the UCA assembly.

Ensure that the RCG Block is securely fastened to a rigid part of the machine structure using the two mounting holes provided, as close to the accumulator as is practicable. Remove the charging valve from the accumulator and fit a suitable pipe-fitting in its place. Using suitably rated steel pipe, connect the accumulator to the RCG Block via port A, and ensure that all connections are gas tight.

**Operation Fig. 1****Pre-charging an Accumulator**

Refer to the instructions given in Bulletin HY07-1244-T/UK. Ensure that the nitrogen bottle is closed before making the connections. Remove the protective cover from the charging valve B, then use the charging and gauging kit to connect the nitrogen bottle to the RCG Block.

To charge through the RCG Block, first close bleed valve C and open isolator valve D. Charge to the required pressure and, once the pressure has stabilised and is correct, remove the charging and gauging kit from valve B according to the instructions in Bulletin HY07-1244-T/UK. The pre-charge pressure will now be displayed on the gauge.

During system operation, the pressure gauge should be isolated from the accumulator. Close the isolator valve D and unscrew the bleed valve C until pressure discharges. When the gauge reads zero, retighten bleed valve C and replace the protective cap on charging valve B.

**Checking Pre-Charge**

Before taking any readings or adjusting the pre-charge pressure, the accumulator **must** be isolated from the hydraulic system and the fluid side discharged in order to depressurize it.

Ensure that bleed valve C is fully closed. Open the isolator valve D and read the gas pressure on the gauge. If the pressure requires adjustment, follow the instructions for pre-charging an accumulator above.

If the pressure is correct, close the isolator valve D then release the pressure from the gauge using bleed valve C. Close the bleed valve when the gauge reads zero.

**Ordering Information**

Parker Hannifin UK Sales

Tachbrook Park Drive

Tachbrook Park

Warwick CV34 6TU

Tel. 01926 833800 Fax. 01926 833827

**Need a Parker part?**

Call Parker's European Product Information Centre on 00800 27 27 5374

Visit us at [www.parker.com/eu](http://www.parker.com/eu)

**Warning**

FAILURE OR IMPROPER SELECTION OR IMPROPER USE OF THE PRODUCTS AND/OR SYSTEMS DESCRIBED HEREIN OR RELATED ITEMS CAN CAUSE DEATH, PERSONAL INJURY AND PROPERTY DAMAGE.

This document and other information from Parker Hannifin Corporation, its subsidiaries and authorized distributors provide product and/or system options for further investigation by users having technical expertise. It is important that all aspects of the application are analysed and the information concerning the product or system in the current product catalogue is reviewed. Due to the variety of operating conditions and applications for these products or systems, the user, through its own analysis and testing, is solely responsible for making the final selection of the products and systems and assuring that all performance, safety and warning requirements of the application are met.

The products described herein, including without limitation, product features, specifications, designs, availability and pricing, are subject to change by Parker Hannifin Corporation and its subsidiaries at any time without notice.