

High Pressure Filters

15P/30P Series

MAX 200 l/min - 207 bar



High Pressure Filters

15P/30P Series

Features & Benefits

Features	Advantages	Benefits
Compact aluminium housing	Light weight but still robust design	Reliable and continuous operation both in mobile and industrial applications
Two head sizes and two bowl lengths	Optimised sizing	Efficient filtration
		Right filter for each application
Large ports and wide flow paths	Low differential pressure across housing and element	Higher flow rates possible
		Less lost energy
Microglass III replacement elements	Multi-layered design produced high capacity and efficiency	Great performance value
	Wire support reduces pleat bunching, keeps performance consistent	Reliable performance throughout element life
Visual, electrical and electronic indicators available	Check element condition at a glance	Optimise element life, prevent bypassing
	Right style for the application	Matches your system electrical connections

Typical Applications

- Saw mills
- Aircraft ground support equipment
- Asphalt pavers
- Hydraulic fan drives
- Power steering circuits
- Domestic refuse vehicles
- Cement trucks
- Servo control protection
- Logging equipment



The Parker Filtration 15P/30P Series High Pressure Filters.

These application examples have one thing in common...the need for clean hydraulic fluid.

Modern high pressure hydraulic systems are demanding. Better controls and long component life are expected. To deliver the high standards of performance, hydraulic components are built with tighter tolerances which increases their sensitivity to contamination.

That's where Parker pressure filters come into play. They filter out ingress contamination before it jams a valve or scores a cylinder. They block pump generated debris before it gets to servo or proportional valves. Parker pressure filters are a key ingredient in meeting today's system demands.

Put your hydraulic systems in the care of Parker Filtration. We are committed to designing and building the best filters available to industry.

Specification

Pressure ratings:

Maximum allowable operating pressure 207 bar.
Filter housing pressure pulse fatigue tested: 138 bar.

Connections:

Inlet and outlet connections are threaded.

Connection style	Model	
BSPF(G)	15P	30P
ISO 6149	3/4"	1"
	M27	M33

Filter housing:

Head material extruded aluminium (anodised 6061-T6).
Bowl material impacted aluminium (anodised 6061-T6).

Seal material:

Nitrile or Fluoroelastomer.

Operating temperature range:

-20°C to +100°C.

Bypass valve:

Opening pressure 3.5 bar.

Filter element:

Degree of filtration:

Determined by multipass-test according to ISO 16889, see Box 3 in the product configurator.

Flow fatigue characteristics:

Filter media is supported so that the optimal fatigue life is achieved (ISO 3724).

Microglass III:

Supported with epoxy coated metal wire mesh, end cap material reinforced composite and metal inner core. Collapse rating 24 bar (ISO 2941).

High collapse elements:

High collapse elements available. For details please contact Parker Filtration.

Indicator options:

Indicating differential pressure: 2.5 ± 0.2 bar.

- visual M3.
 - electrical T1.
 - electronic F1 (PNP).
 - electronic F2 (NPN).
- For indicator details see catalogue section 6.

Weights (kg):

Model	Length 1	Length 2
15P	1.6	2.1
30P	2.9	3.9

Fluid compatibility:

Suitable for use with mineral and vegetable oils, and some synthetic oils. For other fluids, please consult Parker Filtration.

Installation Details

15P Series

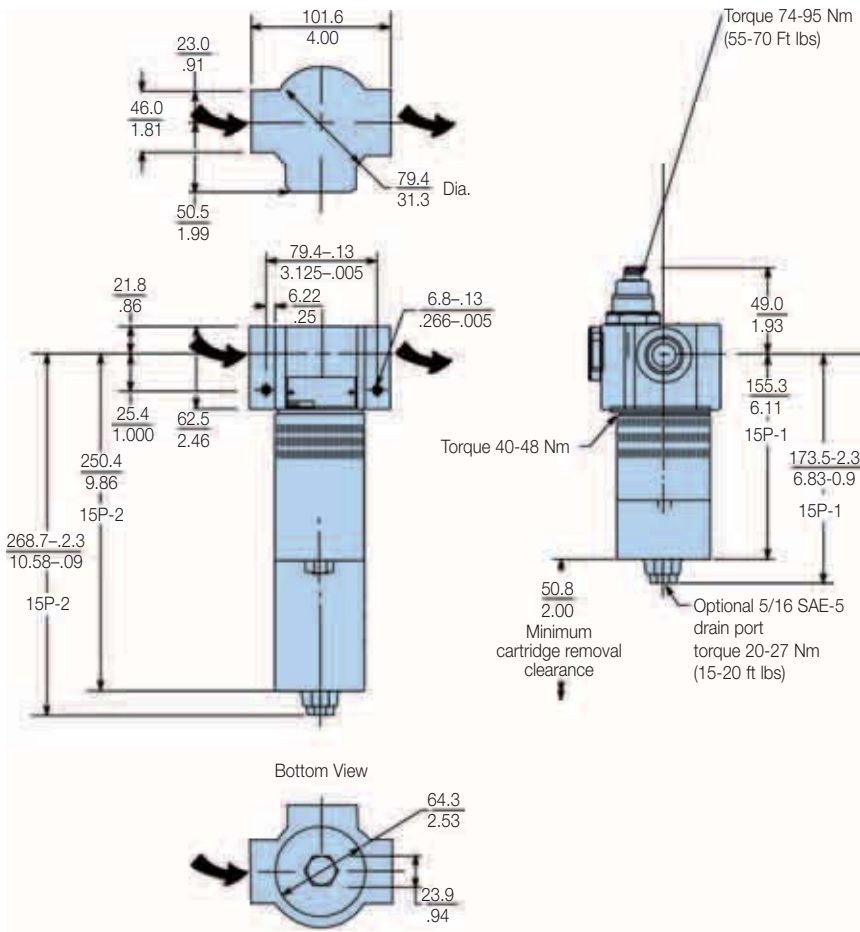

15P/30P Series

Installation Details (cont.)

30P Series

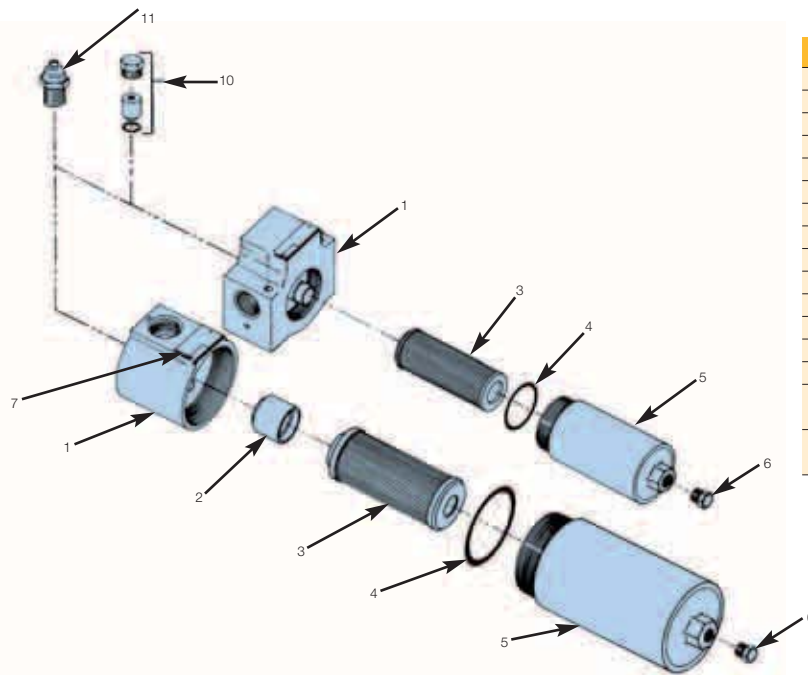
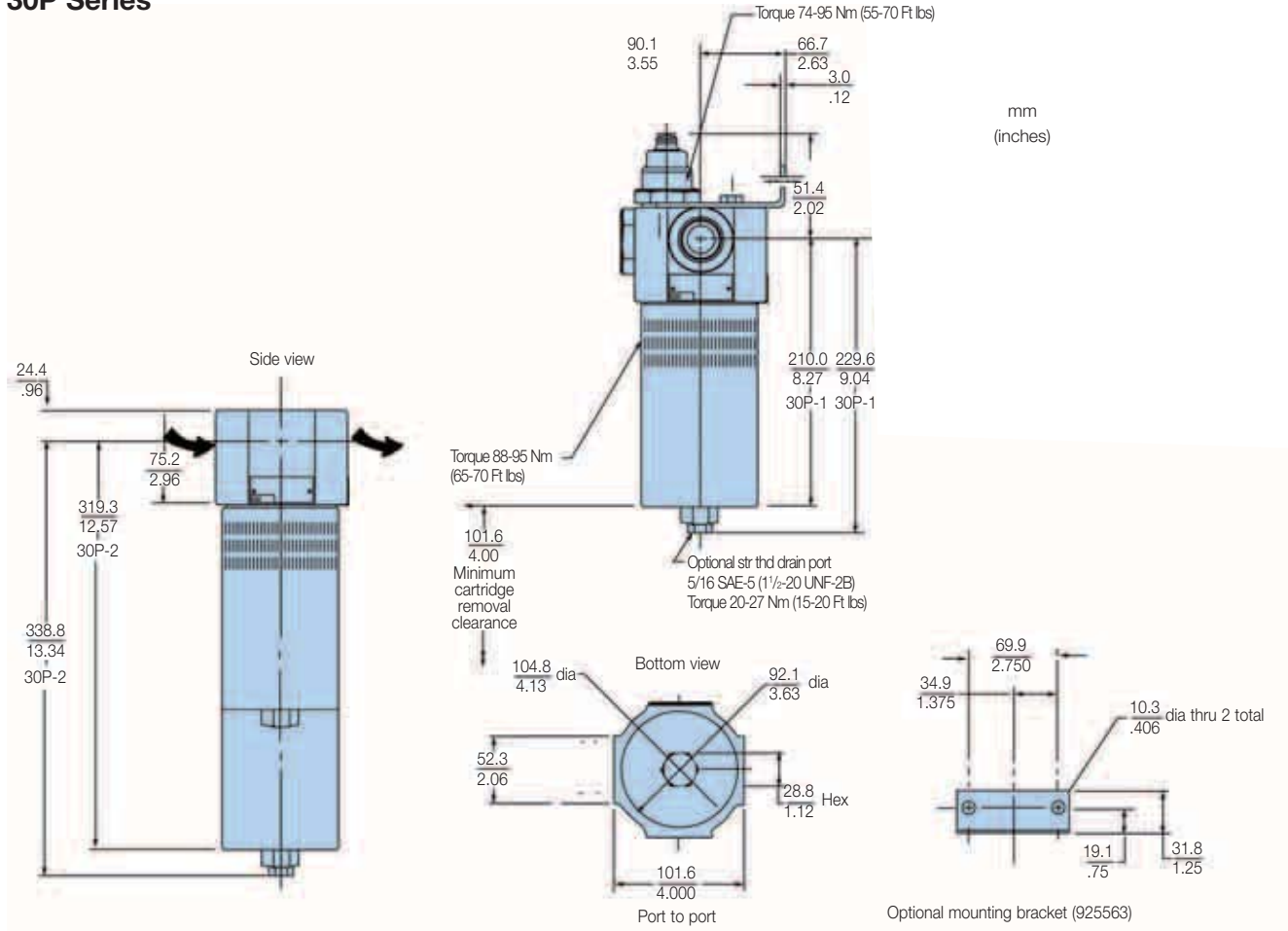

Index	Description	15P	30P
1	Head		
2	Bypass assembly		
3	Element	See chart in product configurator	
4	Bowl O-ring – buna	N92138	N92151
	Bowl O-ring – fluoroelastomer	V92138	V92151
5	Bowl		
6	Drain plug – c/w buna seal		
	Drain plug – c/w Fluoroelastomer seal		
7	Nameplate		
10	Blank indicator kit		
11	Indicators		
	M3 – Visual auto reset indicator	FMUM3KVAU14M	
	T1 – Electrical indicator	FMUT1KVAU14M	
	F1 – Electronic indicator PNP with 4 LED	FMUF1KVAU14M	
	F2 – Electronic indicator NPN with 4 LED	FMUF2KVAU14M	

Pressure Drop Curves

The recommended level of the initial pressure drop is max. 1.2 bar.

If the medium used has a viscosity different from 30 cSt, pressure drop over the filter can be estimated as follows:

$$\Delta p = (\Delta p_{30} \times \text{viscosity of medium used}) / 30 \text{ cSt.}$$

15P Empty Housing

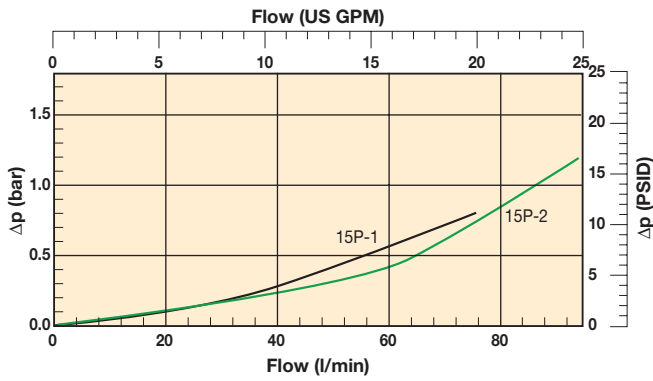

30P Empty Housing

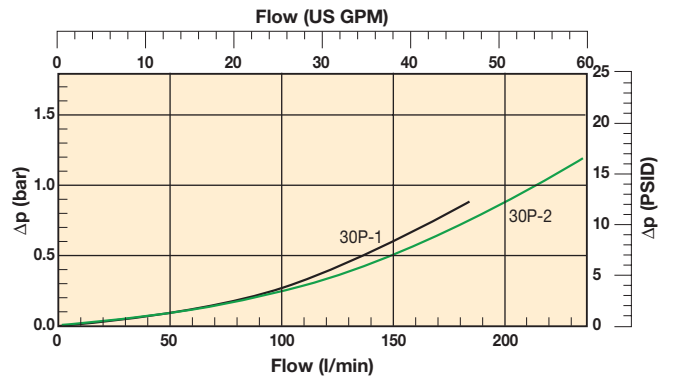

15P-1 Elements

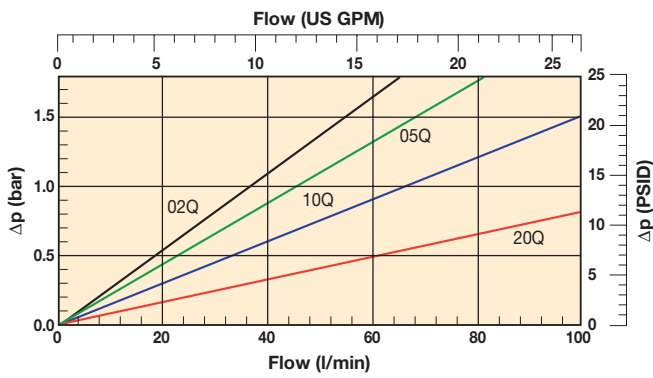

30P-1 Elements

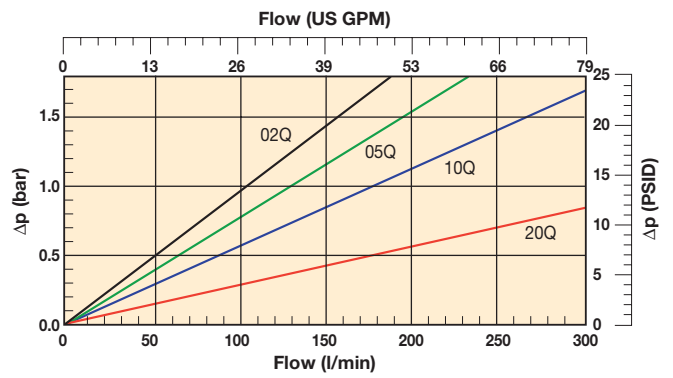

15P-2 Elements

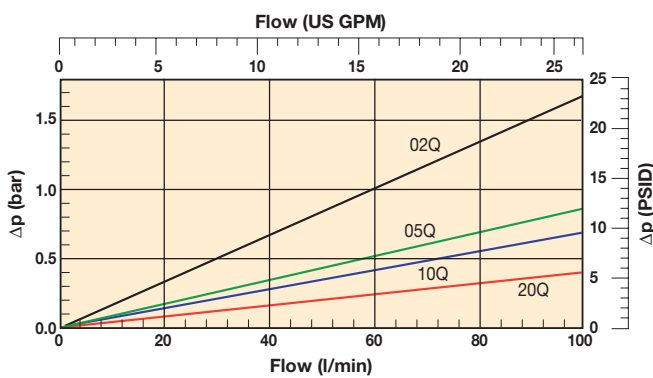

30P-2 Elements

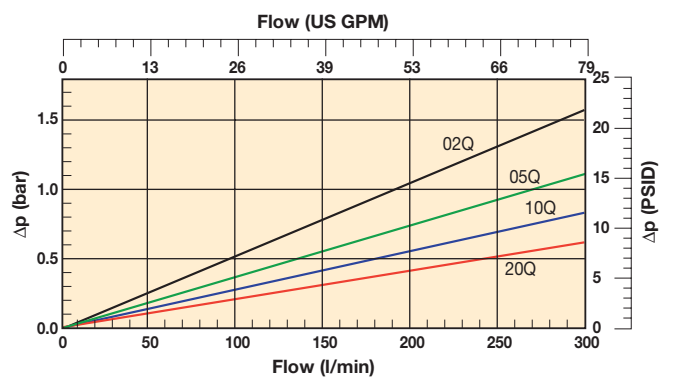

15P/30P Series

Ordering Information

Standard products table

Part number	Supersedes	Flow (l/min)	Model number	Element length	Media rating (µ)	Seals	Indicator	Bypass settings	Ports	Replacement elements
15P110QBM3KG121	15P-1-10Q-M2-50-B2B2-1	45	15P	Length 1	10	Nitrile	Visual	3.5 bar	G ³ / ₄ "	939102Q
15P110QBT1KG121	15P-1-10Q-TW3-50-B2B2-1	45	15P	Length 1	10	Nitrile	Electrical	3.5 bar	G ³ / ₄ "	939102Q
15P210QBM3KG121	15P-2-10Q-M2-50-B2B2-1	70	15P	Length 2	10	Nitrile	Visual	3.5 bar	G ³ / ₄ "	939106Q
15P210QBT1KG121	15P-2-10Q-TW3-50-B2B2-1	70	15P	Length 2	10	Nitrile	Electrical	3.5 bar	G ³ / ₄ "	939106Q
30P110QBM3KG161	30P-1-10Q-M2-50-C2C2-1	120	30P	Length 1	10	Nitrile	Visual	3.5 bar	G1"	939110Q
30P110QBT1KG161	30P-1-10Q-TW3-50-C2C2-1	120	30P	Length 1	10	Nitrile	Electrical	3.5 bar	G1"	939110Q
30P210QBM3KG161	30P-2-10Q-M2-50-C2C2-1	170	30P	Length 2	10	Nitrile	Visual	3.5 bar	G1"	939114Q
30P210QBT1KG161	30P-2-10Q-TW3-50-C2C2-1	170	30P	Length 2	10	Nitrile	Electrical	3.5 bar	G1"	939114Q

Note: Filter assemblies ordered from the product configurator below are on extended lead times. Where possible, please make your selection from the table above.

Note 1: Part numbers featured with bold highlighted codes will ensure a 'standard' product selection.

Note 2: Alternate displayed part number selection will require you to contact Parker Filtration for availability.

Product configurator

Box 1	Box 2	Box 3	Box 4	Box 5	Box 6	Box 7	Box 8
15P	1	10Q	B	M3	K	G12	1

Box 1

Code	
Model	Code
High pressure filter, T-port	15P
High pressure filter, T-port	30P

Highlights Key (Denotes part number availability)

123	Item is standard
123	Item is standard with "green" options
123	Item is semi standard
123	Item is non standard

Note: Standard items are in stock, semi standard items are available within four weeks

Box 2

Filter type	
Length	Code
Length 1	1
Length 2	2

Box 3

Degree of filtration				
Element media	Glass fibre			
	2µ media	5µ media	10µ media	20µ media
Microglass III element	02Q	05Q	10Q	20Q

Box 4

Seal type	
Seal material	Code
Nitrile	B
Fluoroelastomer	V

Box 5

Indicator	
	Code
Plugged with steel plug	P
Visual indicator	M3
Electrical indicator	T1
No indicator port	N
Electronic 4 LED, PNP, N.O.	F1
Electronic 4 LED, NPN, N.O.	F2
Electronic 4 LED, PNP, N.C.	F3
Electronic 4 LED, NPN, N.C.	F4

Box 6

Bypass and indicator settings		
Bypass valve	Indicator	Code
3.5 bar	2.5 bar	K

When filter includes a bypass valve but not an indicator, code denotes bypass setting.

Box 7

Filter connection	
Connections	Code
15P: Thread G ¹ / ₂	G12
Thread M27, ISO 6149	M27
30P: Thread G 1	G16
Thread M33, ISO 6149	M33

Box 8

Options	
Options	Code
Standard	1
Drain port on bowl	4

Replacement elements with nitrile seals				
Media	15P-1	15P-2	30P-1	30P-2
02Q	939100Q	939104Q	939108Q	939112Q
05Q	939101Q	939105Q	939109Q	939113Q
10Q	939102Q	939106Q	939110Q	939114Q
20Q	939103Q	939107Q	939111Q	939115Q

Nominal flow (l/min) at viscosity 30 cSt

Filter model	02Q	05Q	10Q	20Q
15P-1	25	30	45	70
15P-2	40	60	70	90
30P-1	70	90	120	170
30P-2	120	150	170	200

Degree of filtration						Code	
Average filtration beta ratio β (ISO 16889) / particle size µm [c]							
βx(c)=2	βx(c)=10	βx(c)=75	βx(c)=100	βx(c)=200	βx(c)=1000	Disposable Microglass III	
% efficiency, based on the above beta ratio (βx)							02Q
50.0%	90.0%	98.7%	99.0%	99.5%	99.9%		
N/A	N/A	N/A	N/A	N/A	4.5	05Q	
N/A	N/A	4.5	5	6	7		
N/A	6	8.5	9	10	12	10Q	
6	11	17	18	20	22		

High Pressure Filters

100P Series

MAX 1000 l/min - 414 bar



100P Series

Features & Benefits

Features	Advantages	Benefits
High 414 bar pressure rating	Strong and robust housing for heavy duty applications	Reliable and continuous operation for open and closed loop applications
Flow rates up to 1000 l/min	Pressure filtration possible for high flow rates	Excellent protection of high performance machinery
Optional reverse flow valve	Allows reverse flow and prevents back wash of element	Ideal for applications where back flow is expected
Bottom access bowl	Only bottom of the bowl must be opened for element change	Easy service
Microglass III replacement elements	Multi-layered design produced high capacity and efficiency	Great performance value
	Wire support reduces pleat bunching, keeps performance consistent	Reliable performance throughout element life
Visual and electrical indicators available	Check element condition at a glance	Reduces downtime, maximises element life
	Right style for the application	Optimises element life, prevents bypassing
		Matches your system electrical connections

Typical Applications

- Drilling rigs
- Power packs
- Oil/gas industry
- Flight simulators
- Test rigs

The Parker Filtration Model 100P High Pressure Filters.

The 100P Series is designed to meet the growing demand for high-pressure filters with a flow rate capacity of up to 1000 l/min at 414 bar working pressure. For systems where reverse flow can be expected, an optional integrated reverse flow valve avoids back wash of contamination. When changing the element, only the end cap of the bowl has to be removed. The filter is ideal for applications where space is at a premium. The filter media used in the elements is high quality Microglass III glass fibre.



100P Series

Additional Information

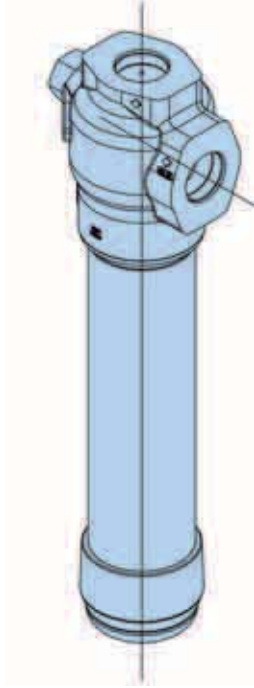

Filter with Reverse Flow Valve

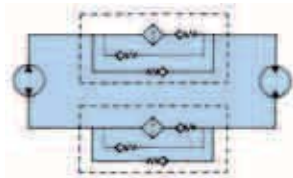

Circuit symbol

Normal Flow Condition

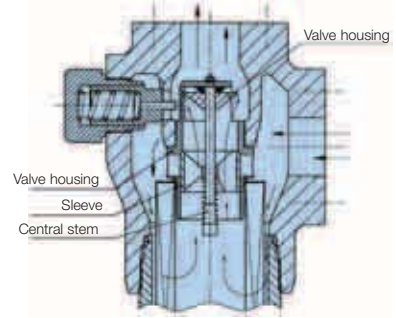

Reverse Flow Condition

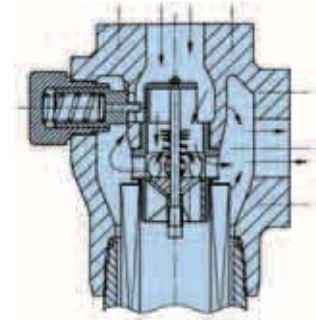

Pressure Drop Curves

The recommended level of the initial pressure drop is max. 2.3 bar.
 If the medium used has a viscosity different from 30 cSt, pressure drop can be estimated as follows:
 The total $\Delta p = \text{housing } \Delta p_h + (\text{element } \Delta p_e \times \text{working viscosity}/30)$.

100P-1 Empty Housing (G1½", SAE 24, SAE 1½")

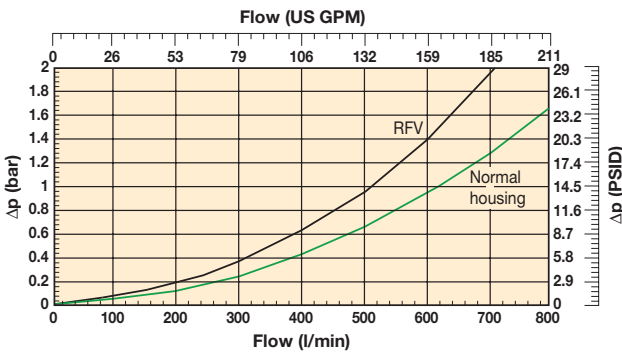

100P-2 Empty Housing (G2", SAE 32, SAE 2")

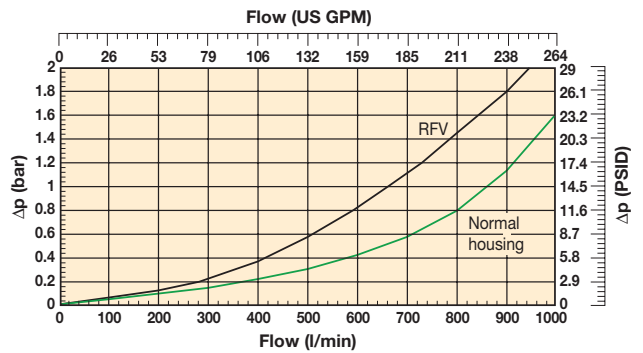

100P-1 Elements

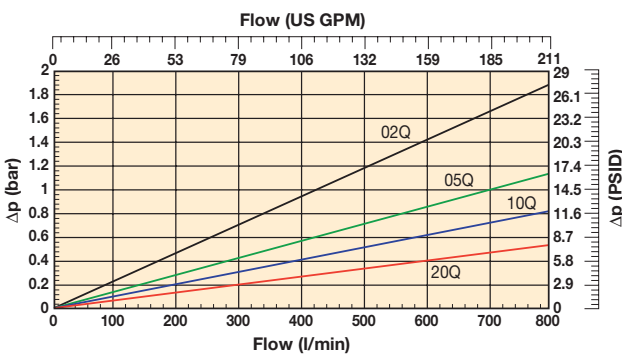

100P-2 Elements

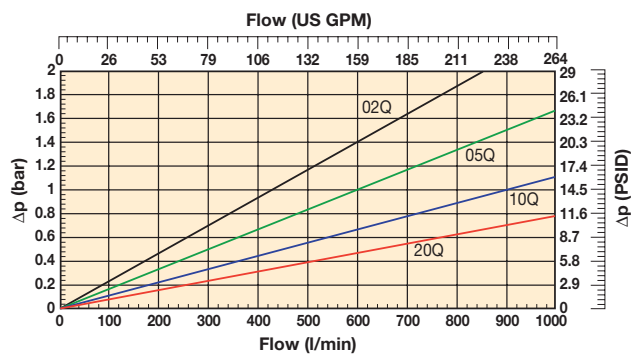

Ordering Information

Standard products table

Part number	Supersedes	Flow (l/min)	Model number	Element length	Media rating (µ)	Seals	Indicator	Bypass settings	Ports	Replacement elements	Supersedes
100P105QBM4MF241	1074A.2HN70.FZ1210	600	100P	Length 1	5	Nitrile	Visual	7.0 bar	SAE flange 1 1/2" 6000	939061Q	1070Z121A
100P110QBM4MF241	1074A.2HN70.FZ1220	700	100P	Length 1	10	Nitrile	Visual	7.0 bar	SAE flange 1 1/2" 6000	939062Q	1070Z122A
100P120QBM4MF241	1074A.2HN70.FZ1230	800	100P	Length 1	20	Nitrile	Visual	7.0 bar	SAE flange 1 1/2" 6000	939063Q	1070Z123A
100P205QBM4MF321	1074A.2HN70.TZ2210	840	100P	Length 2	5	Nitrile	Visual	7.0 bar	SAE flange 2" 6000	939065Q	1070Z221A
100P210QBM4MF321	1074A.2HN70.TZ2220	920	100P	Length 2	10	Nitrile	Visual	7.0 bar	SAE flange 2" 6000	939066Q	1070Z222A
100P220QBM4MF321	1074A.2HN70.TZ2230	1000	100P	Length 2	20	Nitrile	Visual	7.0 bar	SAE flange 2" 6000	939067Q	1070Z223A

Note: Filter assemblies ordered from the product configurator below are on extended lead times. Where possible, please make your selection from the table above.

Product configurator

Box 1	Box 2	Box 3	Box 4	Box 5	Box 6	Box 7	Box 8
100P	2	10Q	B	M4	M	F32	1

Box 1

Code	
Model	Code
Large HP filter, L-port	100P

Box 2

Filter type	
Length	Code
Length 1	1
Length 2	2

Box 3

Degree of filtration				
Element media		Glass fibre		
		2µ media	5µ media	10µ media
		20µ media		
Microglass III element	02Q	05Q	10Q	20Q

Box 4

Seal type	
Seal material	Code
Nitrile	B
Fluoroelastomer	V

Box 5

Indicator	
	Code
No indicator port	N
Visual indicator	M4
Electrical indicator	T2
Electrical indicator with red lamp 28 Vdc, N.O.	T3
Electrical indicator with red lamp 110 VAC, N.O.	T4
Electrical indicator with red lamp 250 VAC, N.O.	T5

Box 6

Bypass and indicator settings		
Bypass valve	Indicator	Code
7.0 bar	5.0 bar	M

When filter includes a bypass valve but not an indicator, code denotes bypass setting.

Box 7

Filter connection	
Connections	Code
Thread G 1 1/2	G24
Thread G 2	G32
Thread SAE 24	S24
Thread SAE 32	S32
SAE flange 1 1/2" 6000	F24
SAE flange 1 1/2" 6000-M	H24
SAE flange 2" 6000	F32
SAE flange 2" 6000-M	H32

Box 8

Options	
Options	Code
Standard	1
Reverse flow valve	3

Replacement elements with nitrile seals		
Media	Length 1	Length 2
02Q	939060Q	939064Q
05Q	939061Q	939065Q
10Q	939062Q	939066Q
20Q	939063Q	939067Q

Nominal flow (l/min) at viscosity 30 cSt				
Filter port size	02Q	05Q	10Q	20Q
100P-1, 1 1/2"	540	600	700	800
100P-2, 2"	700	840	920	1000

Highlights Key (Denotes part number availability)

123	Item is standard
123	Item is standard with "green" options
123	Item is semi standard
123	Item is non standard

Note: Standard items are in stock, semi standard items are available within four weeks

Seal kit (nitrile) order code: 8069000070
Mounting clamp order code: 84.47.265.01

Note 1: Part numbers featured with bold highlighted codes will ensure a 'standard' product selection.
Note 2: Alternate displayed part number selection will require you to contact Parker Filtration for availability.

Degree of filtration						Code
Average filtration beta ratio β (ISO 16889) / particle size µm [c]						
βx(c)=2	βx(c)=10	βx(c)=75	βx(c)=100	βx(c)=200	βx(c)=1000	Disposable Microglass III
% efficiency, based on the above beta ratio (βx)						
50.0%	90.0%	98.7%	99.0%	99.5%	99.9%	
N/A	N/A	N/A	N/A	N/A	4.5	05Q
N/A	N/A	4.5	5	6	7	10Q
N/A	6	8.5	9	10	12	20Q
6	11	17	18	20	22	

High Pressure Filters

18/28/38P Series

MAX 700 l/min - 414 bar



High Pressure Filters

18/28/38P Series

Features & Benefits

Features	Advantages	Benefits
Fatigue tested to full pressure rating	Strong and robust housing for heavy duty applications	Reliable and continuous operation both in mobile and industrial applications
Several head sizes	Optimised sizing	Efficient filtration Covers wide flow range
Several connection options	Easy mounting	Global design, global acceptance Right filter for each application
Microglass III replacement elements	Multi-layered design produced high capacity and efficiency	Great performance value
	Wire support reduces pleat bunching, keeps performance consistent	Reliable performance throughout element life Reduces downtime, maximises element life
Visual, electrical and electronic indicators available	Check element condition at a glance	Optimises element life, prevents bypassing
	Right style for the application	Matches your system electrical connections

Typical Applications

- Injection moulding
- Die casting
- Servo controls
- Machine tools
- Mobile equipment

The Parker Filtration 18/28/38P Series High Pressure Filters

Parker Filtration engineered the 18/28/38P series of high pressure filters to satisfy demanding applications in the mobile and industrial markets throughout the world. With metric mounting and optional ISO 6149 ports, this new series is truly a global design.

Installed downstream of the pump, this new series with their wide range of high capacity Microglass III elements, offer excellent protection to system components.

Standard filters come complete with industry proven spool type bypass valve. For more critical applications such as servo or proportional controls, a no bypass high strength element combination ensures maximum protection.

The modular low hysteresis differential pressure indicator fitted to this series is unrivaled in its performance. Tests prove its accuracy and foolproof design to be a major advance in indicator technology.

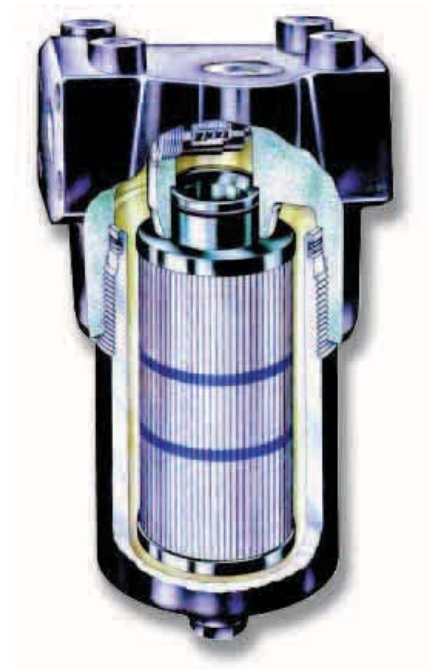

Specification

Pressure ratings:

Maximum allowable operating pressure 414 bar.
Filter housing pressure pulse fatigue tested: 10⁶ pulses 0 - 414 bar.

Connections:

Inlet and outlet connections are threaded internally or flange faced.

Connection style	Model		
	18P	28P	38P
BSPF(G)	3/4"	1"	1 1/4", 1 1/2"
SAE	12	16	20, 24
ISO 6149	M27	M33	M42, M48
Flange SAE 6000	3/4"	1"	1 1/4"
Flange SAE 6000-M*	3/4"	1"	1 1/4"

*6000-M is a SAE style with appropriate metric fixing threads.

Filter housing:

Head material cast iron (GSI).
Bowl material steel.

Seal material:

Nitrile or Fluoroelastomer.

Operating temperature range:

-20°C to +100°C.

Bypass valve & indicator settings:

Table below gives bypass valve and corresponding indicator setting.

Bypass	Indicator
3.5 bar	2.5 bar
7.0 bar	5.0 bar

Filter element:

Degree of filtration:

Determined by multipass-test according to ISO 16889, see Box 3 in the product configurator.

Flow fatigue characteristics:

Filter media is supported so that the optimal fatigue life is achieved (ISO 3724).

Microglass III:

Supported with epoxy coated metal wire mesh, end cap material reinforced composite and metal inner core. Collapse rating 20 bar (ISO 2941).

High collapse elements:

(to be used when no bypass function in filter housing).

Microglass III media supported with epoxy coated metal wire mesh on upstream and stainless steel on downstream, end cap material steel. Strong metal inner core. Collapse rating 210 bar (ISO 2941).

Indicator options:

Indicating differential pressure: 2.5 ± 0.2 bar or 5.0 ± 0.4 bar.

- visual M3.
- electrical T1.
- electronic F1(PNP).
- electronic F2(NPN).

For indicator details see catalogue section 6.

Weights (kg):

Model	Length 1	Length 2
18P	4.2	5.7
28P	6.7	9.2
38P	15.8	20.3

Fluid compatibility:

Suitable for use with mineral and vegetable oils, and some synthetic oils. For other fluids, please consult Parker Filtration.

Model	A	B	C	D	E (A/F)	F	G	H	J	K	L	M	N	P	
18P-1	198 (7.79)	32 (1.26)	26 (1.02)	75 (2.95)	24 (0.94)	100 (3.94)	98 (3.86)	40 (1.57)	20 (0.79)	80 (3.15)	40 (1.57)	55 (2.16)	110 (4.33)	M8 x 1.25 x12 deep	
18P-2	293 (11.53)														120 (4.72)
28P-1	228 (8.97)	40 (1.57)	29 (1.14)	93 (3.66)	24 (0.94)		160 (6.30)	50 (1.97)	25 (0.98)	120 (4.72)	60 (2.36)	81 (3.19)	162 (6.38)		M10 x 1.5 x11 deep
28P-2	337 (13.26)														
38P-1	329 (12.95)	44 (1.73)	35 (1.38)	128 (5.04)	36 (1.42)		160 (6.30)	50 (1.97)	25 (0.98)	120 (4.72)	60 (2.36)	81 (3.19)	162 (6.38)		
38P-2	448 (17.64)					120 (4.72)								55 (2.16)	

18P

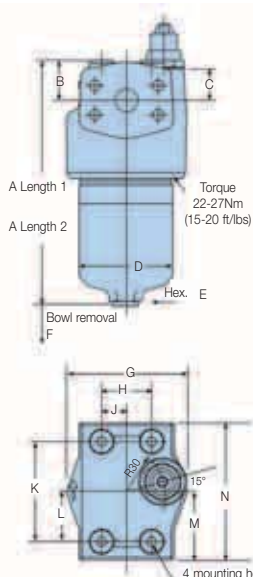

28P

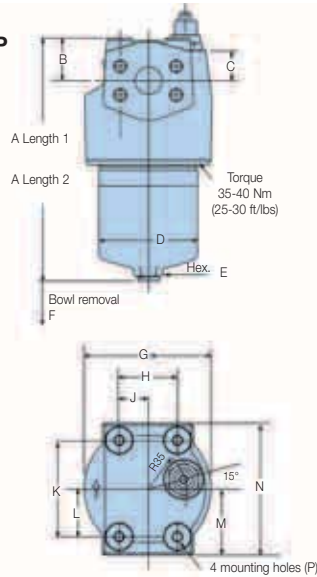

38P

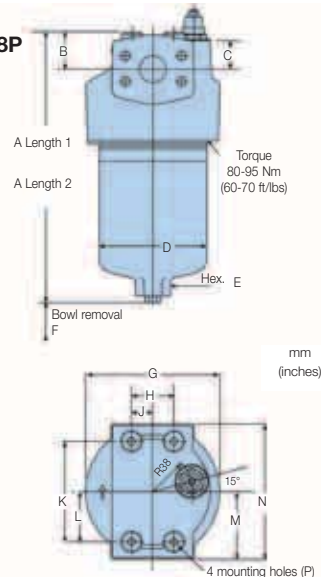

High Pressure Filters

18/28/38P Series

Flange Face Details

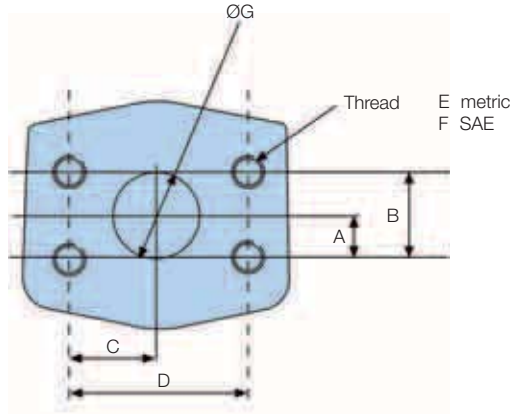

Model mm (inches)	A	B	C	D	E	F	G
18P (3/4")	11.9 (0.47)	23.8 (0.94)	25.4 (1.00)	50.8 (2.0)	M10 x 1.5-6H x 18 Deep	3/8-16 UNC-2B x 18 deep	19.0 (0.75)
28P (1")	14 (0.55)	27.8 (1.09)	28.0 (1.10)	57.1 (2.25)	M12 x 1.75-6H x 20 Deep	7/16-14 UNC-2B x 20 deep	25.4 (1.0)
38P (1 1/4")	15.7 (0.62)	31.7 (1.25)	33.0 (1.30)	66.7 (2.62)	M14 x 2-6H x 20 Deep	1/2-13 UNC-2B x 20 deep	31.8 (1.25)

Pressure Drop Curves

With 3.5 bar bypass the recommended initial pressure drop is max 1.2 bar.

With 7.0 bar bypass the recommended initial pressure drop is max 2.3 bar.

If the medium used has a viscosity different from 30 cSt, pressure drop over the filter can be estimated as follows:

The total $\Delta p = \text{housing } \Delta p_h + (\text{element } \Delta p_e \times \text{working viscosity}/30)$.

18P-1 Elements

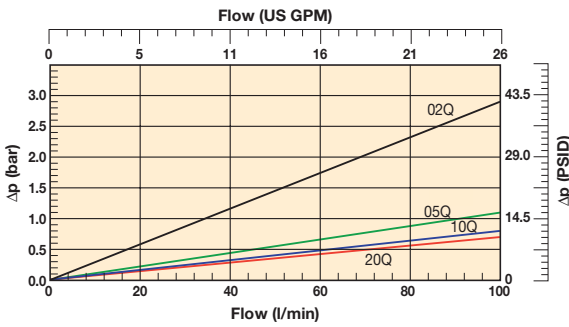

18P-2 Elements

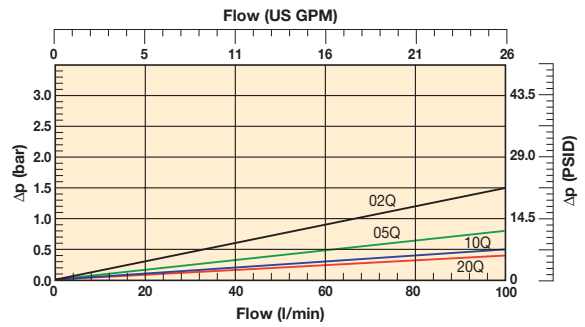

18P-1 Empty Housing and High Collapse

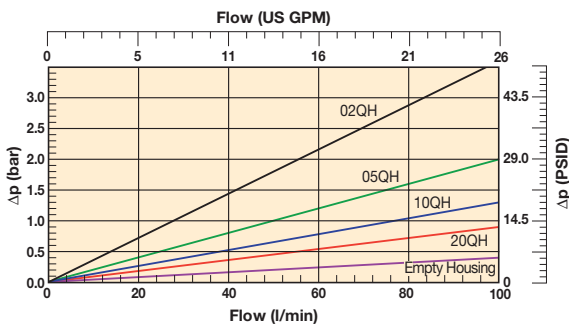

18P-2 High Collapse Elements

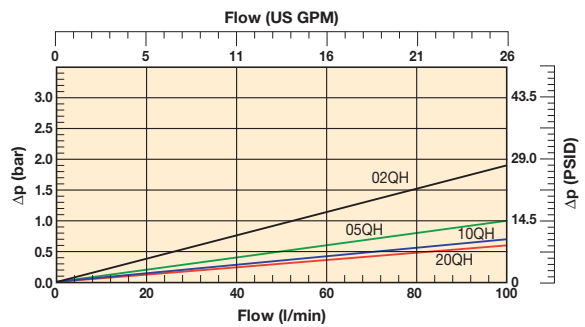

28P-1 Elements

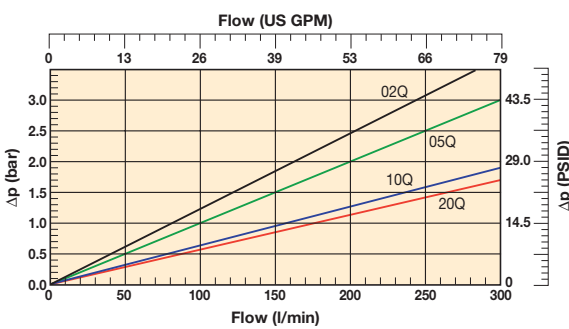

28P-2 Elements

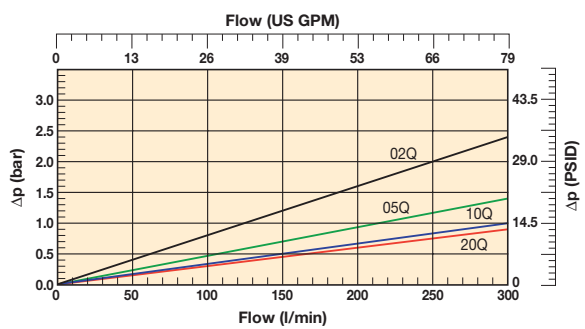

28P-1 Empty Housing and High Collapse

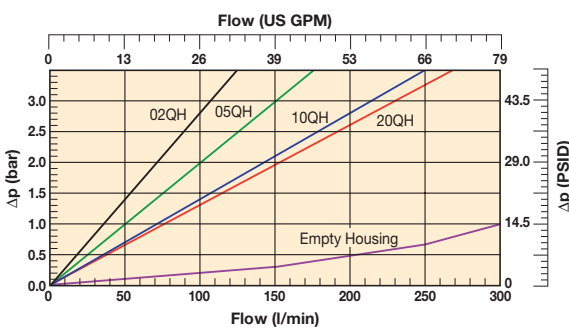

28P-2 High Collapse Elements

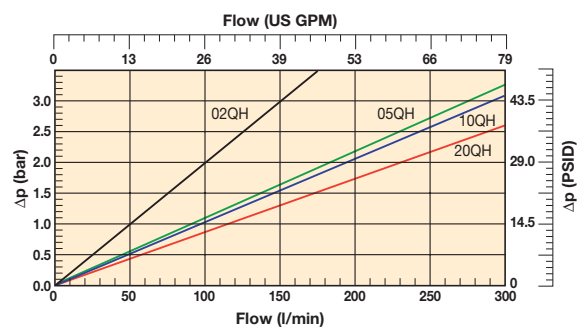

18/28/38P Series

Pressure Drop Curves (cont.)

38P-1 Elements

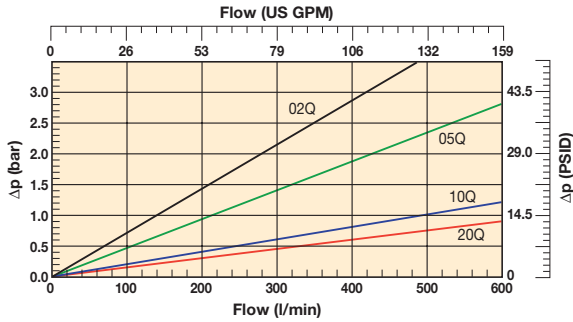

38P-2 Elements

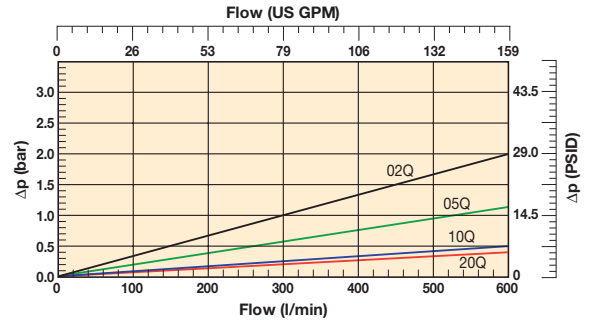

38P-1 Empty Housing and High Collapse

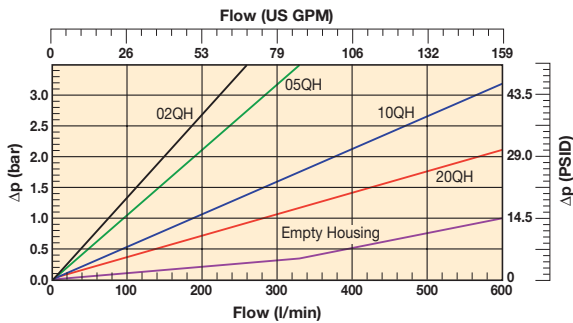

38P-2 High Collapse Elements

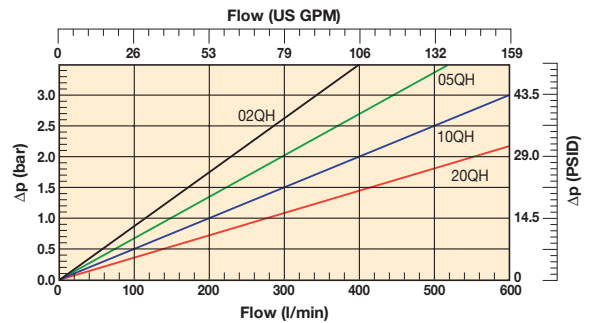

Element Service

- A. Stop the system's power unit.
- B. Relieve any system pressure in the filter line.
- C. Drain the filter bowl if drain port option is provided.
- D. Rotate the bowl clockwise (left) and remove.
- E. Remove element by pulling downward with a slight twisting motion and discard.
- F. Check bowl o-ring and anti-extrusion ring for damage and replace if necessary.
- G. Lubricate element o-ring with system fluid and locate element in filter head.
- H. Install bowl by rotating counter-clockwise (right) and tighten to specified torque.
 - 18P – 22-27 Nm
 - 28P – 35-40 Nm
 - 38P – 80-95 Nm
- I. Confirm there are no leaks after powering the system.

Parts List

Index	Description	Part number
1	Head Assembly	
2	Element	see table on next page
3	Bowl	
	Indicators	
4	M3 – Visual auto reset; 2.5 bar	
	M3 – Visual auto reset; 5.0 bar	
5	T1 – Electrical; 2.5 bar with DIN 43650 Connector	
	T1 – Electrical; 5.0 bar with DIN 43650 Connector	
	F1 – Electronic PNP; 2.5 bar with 4 LED	
	F2 – Electronic NPN; 2.5 bar with 4 LED	
	F1 – Electronic PNP; 5.0 bar with 4 LED	
	F2 – Electronic NPN; 5.0 bar with 4 LED	
6	Bowl Seal	
7	Bowl Anti-extrusion Ring	
	Seal Kits	
	Seal kit 18P (std) – Nitrile	S04350
	Seal kit 18P (F3) – Fluoroelastomer	S04351
	Seal kit 28P (std) – Nitrile	S04352
	Seal kit 28P (F3) – Fluoroelastomer	S04353
	Seal kit 38P (std) – Nitrile	S04354
	Seal Kit 38P (F3) – Fluoroelastomer	S04355

Element Service (cont.)

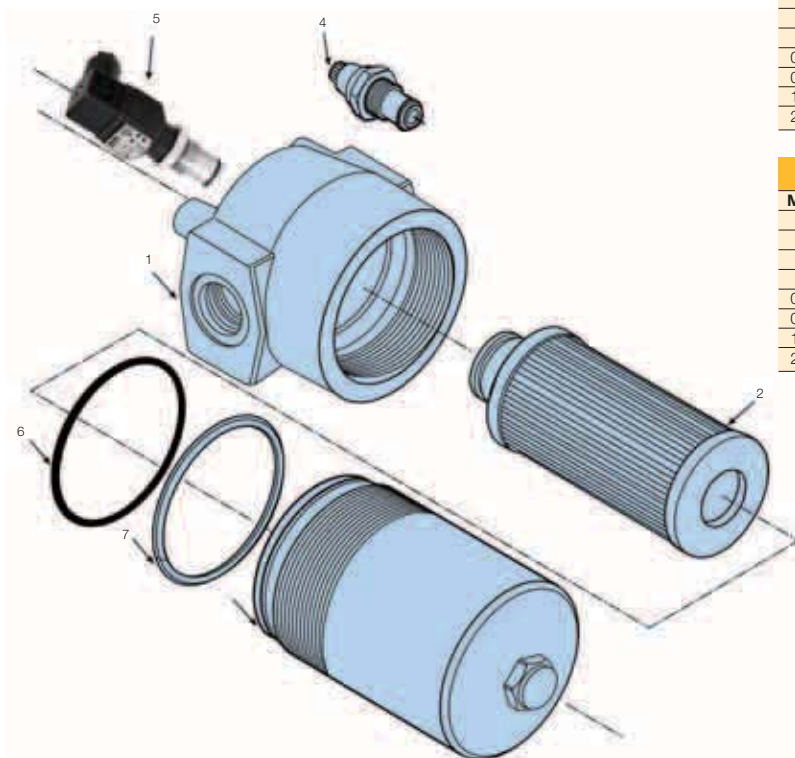

Replacement element part numbers

Elements with Nitrile seals						
Model	18P-1	18P-2	28P-1	28P-2	38P-1	38P-2
02Q	G04242	G04250	G04258	G04266	G04274	G04282
05Q	G04243	G04251	G04259	G04267	G04275	G04283
10Q	G04244	G04252	G04260	G04268	G04276	G04284
20Q	G04245	G04253	G04261	G04269	G04277	G04285
02QH	G04290	G04298	G04306	G04314	G04322	G04330
05QH	G04291	G04299	G04307	G04315	G04323	G04331
10QH	G04292	G04300	G04308	G04316	G04324	G04332
20QH	G04293	G04301	G04309	G04317	G04325	G04333

Elements with Fluoroelastomer seals						
Model	18P-1	18P-2	28P-1	28P-2	38P-1	38P-2
02Q	G04236	G04254	G04262	G04270	G04278	G04286
05Q	G04237	G04255	G04263	G04271	G04279	G04287
10Q	G04238	G04256	G04264	G04272	G04280	G04288
20Q	G04239	G04257	G04265	G04273	G04281	G04289
02QH	G04294	G04202	G04310	G04318	G04326	G04334
05QH	G04295	G04203	G04311	G04319	G04327	G04335
10QH	G04296	G04304	G04312	G04320	G04328	G04336
20QH	G04297	G04305	G04313	G04321	G04329	G04337

Ordering Information

Standard products table

Part number	Supersedes	Flow (l/min)	Model number	Element length	Media rating (µ)	Seals	Indicator	Bypass settings	Ports	Replacement elements
18P110QBT1MG121	18P-1-10Q-TW6-98-B2B2-1	80	18P	Length 1	10	Nitrile	Electrical	7.0 bar	G $\frac{3}{4}$ "	G04244
18P110QBM3MG121	18P-1-10Q-M2-98-B2B2-1	80	18P	Length 1	10	Nitrile	Visual	7.0 bar	G $\frac{3}{4}$ "	G04244
18P120QBT1MG121	18P-1-20Q-TW6-98-B2B2-1	100	18P	Length 1	20	Nitrile	Electrical	7.0 bar	G $\frac{3}{4}$ "	G04245
18P120QBM3MG121	18P-1-20Q-M2-98-B2B2-1	100	18P	Length 1	20	Nitrile	Visual	7.0 bar	G $\frac{3}{4}$ "	G04245
18P210QBT1MG121	18P-2-10Q-TW6-98-B2B2-1	130	18P	Length 2	10	Nitrile	Electrical	7.0 bar	G $\frac{3}{4}$ "	G04252
18P210QBM3MG121	18P-2-10Q-M2-98-B2B2-1	130	18P	Length 2	10	Nitrile	Visual	7.0 bar	G $\frac{3}{4}$ "	G04252
18P220QBT1MG121	18P-2-20Q-TW6-98-B2B2-1	150	18P	Length 2	20	Nitrile	Electrical	7.0 bar	G $\frac{3}{4}$ "	G04253
18P220QBM3MG121	18P-2-20Q-M2-98-B2B2-1	150	18P	Length 2	20	Nitrile	Visual	7.0 bar	G $\frac{3}{4}$ "	G04253
28P110QBT1MG161	28P-1-10Q-TW6-98-C2C2-1	120	28P	Length 1	10	Nitrile	Electrical	7.0 bar	G1"	G04260
28P110QBM3MG161	28P-1-10Q-M2-98-C2C2-1	120	28P	Length 1	10	Nitrile	Visual	7.0 bar	G1"	G04260
28P120QBT1MG161	28P-1-20Q-TW6-98-C2C2-1	150	28P	Length 1	20	Nitrile	Electrical	7.0 bar	G1"	G04261
28P120QBM3MG161	28P-1-20Q-M2-98-C2C2-1	150	28P	Length 1	20	Nitrile	Visual	7.0 bar	G1"	G04261
28P210QBT1MG161	28P-2-10Q-TW6-98-C2C2-1	250	28P	Length 2	10	Nitrile	Electrical	7.0 bar	G1"	G04268
28P210QBM3MG161	28P-2-10Q-M2-98-C2C2-1	250	28P	Length 2	10	Nitrile	Visual	7.0 bar	G1"	G04268
38P110QBT1MG201	38P-1-10Q-TW6-98-D2D2-1	340	38P	Length 1	10	Nitrile	Electrical	7.0 bar	G1 $\frac{1}{2}$ "	G04276
38P110QBM3MG201	38P-1-10Q-M2-98-D2D2-1	340	38P	Length 1	10	Nitrile	Visual	7.0 bar	G1 $\frac{1}{2}$ "	G04276
38P120QBT1MG201	38P-1-20Q-TW6-98-D2D2-1	420	38P	Length 1	20	Nitrile	Electrical	7.0 bar	G1 $\frac{1}{2}$ "	G04277
38P120QBM3MG201	38P-1-20Q-M2-98-D2D2-1	420	38P	Length 1	20	Nitrile	Visual	7.0 bar	G1 $\frac{1}{2}$ "	G04277
38P210QBT1MG201	38P-2-10Q-TW6-98-D2D2-1	560	38P	Length 2	10	Nitrile	Electrical	7.0 bar	G1 $\frac{1}{2}$ "	G04284
38P210QBM3MG201	38P-2-10Q-M2-98-D2D2-1	560	38P	Length 2	10	Nitrile	Visual	7.0 bar	G1 $\frac{1}{2}$ "	G04284
38P220QBT1MG201	38P-2-20Q-TW6-98-D2D2-1	700	38P	Length 2	20	Nitrile	Electrical	7.0 bar	G1 $\frac{1}{2}$ "	G04285
38P220QBM3MG201	38P-2-20Q-M2-98-D2D2-1	700	38P	Length 2	20	Nitrile	Visual	7.0 bar	G1 $\frac{1}{2}$ "	G04285

Note: Filter assemblies ordered from the product configurator on the next page are on extended lead times. Where possible, please make your selection from the table above.

High Pressure Filters

18/28/38P Series

Ordering Information (cont.)

Product configurator

Box 1	Box 2	Box 3	Box 4	Box 5	Box 6	Box 7	Box 8
38P	1	10Q	B	M3	M	G20	1

Box 1

Code	
Model	Code
Small size high pressure filter, T-port	18P
Medium size high pressure filter, T-port	28P
Large size high pressure filter, T-port	38P

Highlights Key (Denotes part number availability)

123	Item is standard
123	Item is standard with "green" options
123	Item is semi standard
123	Item is non standard

Note: Standard items are in stock, semi standard items are available within four weeks

Box 2

Filter type	
Length	Code
Length 1	1
Length 2	2

Box 3

Degree of filtration				
Element media	Glass fibre			
	2µ media	5µ media	10µ media	20µ media
Microglass III element	02Q	05Q	10Q	20Q
High collapse element	02QH	05QH	10QH	20QH

Box 4

Seal type	
Seal material	Code
Nitrile	B
Fluoroelastomer	V

Box 5

Indicator	
	Code
No indicator port	N
Visual indicator	M3
Electrical indicator	T1
Plugged with steel plug	P
Electronic 4 LED, PNP, N.O.	F1
Electronic 4 LED, NPN, N.O.	F2
Electronic 4 LED, PNP, N.C.	F3
Electronic 4 LED, NPN, N.C.	F4

Box 6

Bypass and indicator settings		
Bypass valve	Indicator	Code
3.5 bar	2.5 bar	K
7.0 bar	5.0 bar	M
No bypass	5.0 bar	M
No bypass	No indicator	X

+ Box 8: code 2

+ Box 8: code 2

When filter includes a bypass valve but not an indicator, code denotes bypass setting.

Box 7

Filter connection	
Ports	Code
18P: Thread G 3/4	G12
Thread SAE 12	S12
Thread M27, ISO 6149	M27
SAE flange 3/4" 6000-M	H12
SAE flange 3/4" 6000	F12
28P: Thread G 1	G16
Thread SAE 16	S16
Thread M33, ISO 6149	M33
SAE flange 1" 6000-M	H16
SAE flange 1" 6000	F16
38P: Thread G 1 1/4	G20
Thread G 1 1/2	G24
Thread SAE 20	S20
Thread SAE 24	S24
Thread M42, ISO 6149	M42
Thread M48, ISO 6149	M48
SAE flange 1 1/4" 6000-M	H20
SAE flange 1 1/4" 6000	F20

Box 8

Options	
Options	Code
Standard	1
No bypass	2

Nominal flow (l/min) at viscosity 30 cSt

Filter model	02Q	05Q	10Q	20Q
18P-1	35	60	80	100
18P-2	70	110	130	150
28P-1	80	100	120	150
28P-2	140	200	250	300
38P-1	140	220	340	420
38P-2	320	440	560	700

Degree of filtration						Code	
Average filtration beta ratio β (ISO 16889) / particle size µm [c]							
βx(c)=2	βx(c)=10	βx(c)=75	βx(c)=100	βx(c)=200	βx(c)=1000		
% efficiency, based on the above beta ratio (βx)							
50.0%	90.0%	98.7%	99.0%	99.5%	99.9%		
N/A	N/A	N/A	N/A	N/A	4.5	02Q	02QH
N/A	N/A	4.5	5	6	7	05Q	05QH
N/A	6	8.5	9	10	12	10Q	10QH
6	11	17	18	20	22	20Q	20QH

Note 1: Part numbers featured with bold highlighted codes will ensure a 'standard' product selection.

Note 2: Alternate displayed part number selection will require you to contact Parker Filtration for availability.

High Pressure Filters

70/70 Eco Series

MAX 450 l/min - 420 bar

FEATURING
EC GLASS III



70/70 Eco Series

Features & Benefits

Features	Advantages	Benefits
Fatigue tested to full pressure rating	Strong and robust housing for heavy duty applications	Reliable and continuous operation both in mobile and industrial applications
Several head options and connection sizes	Easy mounting	Reduced space and piping Right filter for each application
Several bowl lengths	Optimised sizing	Efficient filtration
Microglass III replacement elements	Multi-layered design produced high capacity and efficiency Wire support reduces pleat bunching, keeps performance consistent	Great performance value Reliable performance throughout element life Reduces downtime, maximises element life
Coreless Ecoglass III replacement elements	No metal content in element Reduced overall weight of 50% Easy compaction of used elements Eco adaptors available	Environmentally friendly disposal by incineration Lower element replacement costs Lower disposal costs Retrofit coreless design to housings already installed
Visual, electrical and electronic indicators available	Check element condition at a glance Right style for the application	Optimise element life, prevent bypassing Matches your system electrical connections

Typical Applications

- Forestry equipment
- Industrial power units
- Pulp and paper
- Port handling equipment
- Mining and quarrying equipment

The Parker Filtration 70/70 Eco Series High Pressure Filters.

High quality 420 bar in-line pressure filters designed to offer high levels of protection at flows up to 450 l/min.

Dirt sensitive systems can be protected with confidence using the 70 Series high pressure filters.

The 70 Series also available with environmentally friendly Ecoglass III elements.



Specification

Pressure ratings:

Maximum allowable operating pressure 420 bar.
Filter housing pressure pulse fatigue tested: 10^6 pulses 0 - 414 bar.

Connections:

Threads G1, G1 $\frac{1}{4}$, G1 $\frac{1}{2}$ (ISO 228/1).
or flanges 1 $\frac{1}{4}$ " SAE 3000-M, 1 $\frac{1}{2}$ " SAE 3000-M, 1 $\frac{1}{4}$ " SAE 6000-M, 1 $\frac{1}{2}$ " SAE 6000-M.

Filter housing:

Head material cast iron (GSI).
Bowl material steel. Max torque 40 Nm.

Seal material:

Nitrile or Fluoroelastomer.

Operating temperature range:

- 20°C to +100°C.

Bypass valve:

Opening pressure 3.5 bar.

Filter element:

Degree of filtration:

Determined by Multipass-test according to ISO 16889, see Box 3 in the product configurator.

Flow fatigue characteristics:

Filter media is supported so that the optimal fatigue life is achieved (ISO 3724).

Microglass III:

Supported with epoxy coated metal wire mesh, end cap material reinforced composite and metal inner core.
Collapse rating 20 bar (ISO 2941).

Ecoglass III:

Supported with plastic net, end cap material reinforced composite.
No metal parts.

Collapse rating 10 bar (ISO 2941).

Filter element can only be used together with reusable FEA Eco-adapter.

Note: Ecoglass III contributes to ISO 14001 quality.

High collapse elements:

(To be used when no bypass function in filter housing).

Microglass III media supported with epoxy coated metal wire mesh on upstream and stainless steel on downstream, end cap material steel. Strong metal inner core. Collapse rating 210 bar (ISO 2941).

Indicator options:

Indicating differential pressure: 2.5 ± 0.2 bar or 7.0 ± 0.5 bar.
2.5 bar indicators to be used with 3.5 bar bypass valve and 7.0 bar indicators with no bypass function.

- visual M3.
- electrical T1.
- electronic F1 (PNP).
- electronic F2 (NPN).

For indicator details see catalogue section 6.

Fluid compatibility:

Suitable for use with mineral and vegetable oils, and some synthetic oils. For other fluids, please consult Parker Filtration.

70/70 Eco Series

Specification

70B

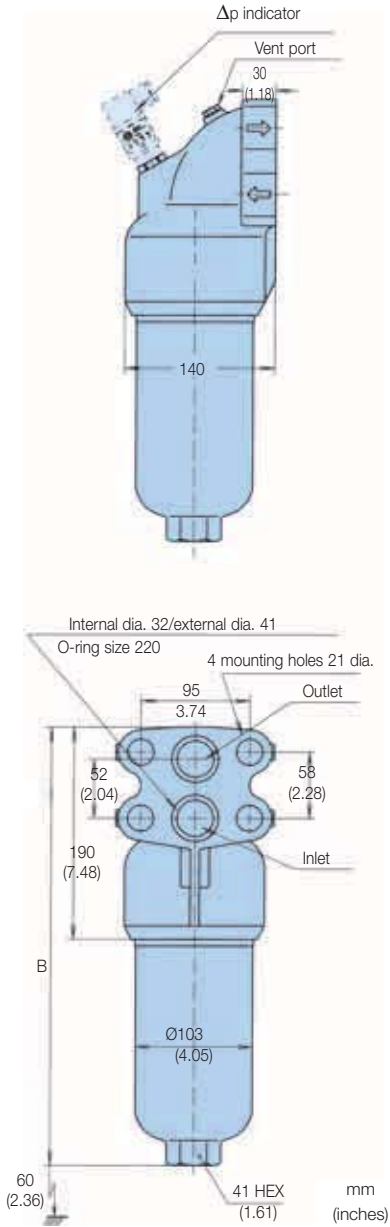

70T

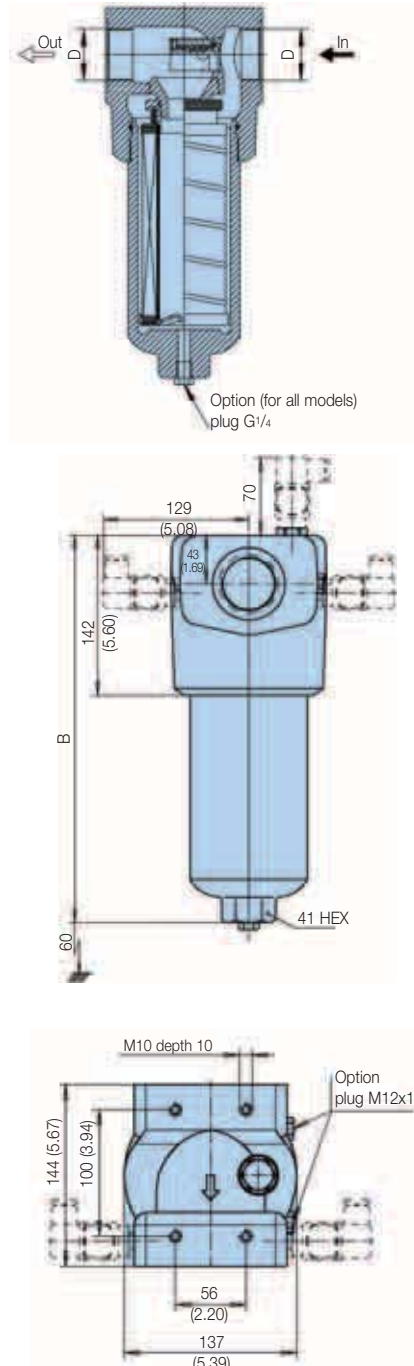

70L

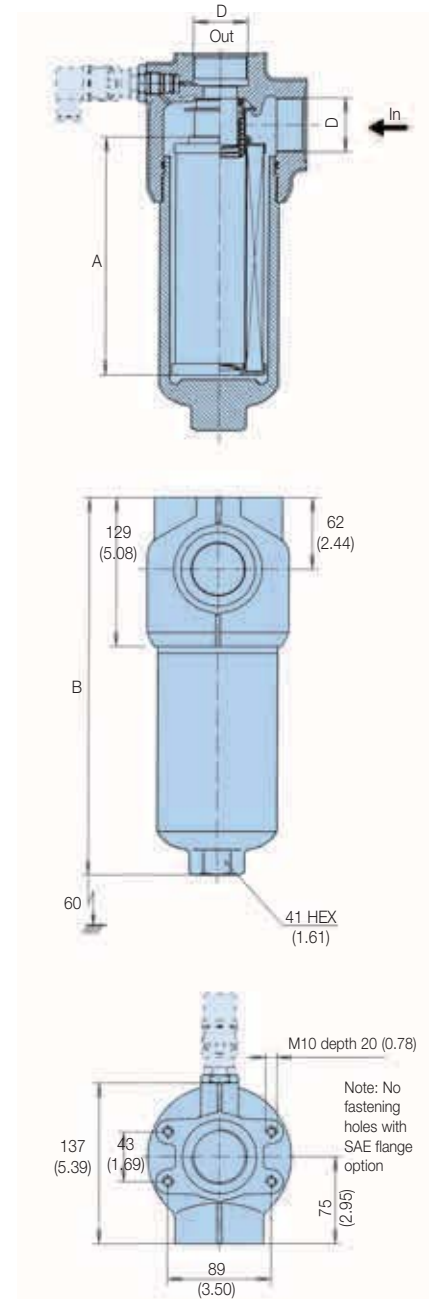

Weights (kg)

Type	70T	70L	70B
Length 1	14	10.5	11.5
Length 2	16.5	13	14
Length 3	19	15.5	16.5
Length 4	22	18.5	19.5

Type	A	B 70T	B 70B	B 70L	Max working pressure	Port D
Length 1	116 (4.57)	249 (9.80)	295 (11.61)	235 (9.25)	420 bar	G1, G1¼ or G1½ Flange 1½ SAE 3000-M Flange 1¼ SAE 3000-M Flange 1½ SAE 6000-M Flange 1¼ SAE 6000-M
Length 2	208 (8.19)	342 (13.46)	390 (15.35)	330 (13.00)		
Length 3	329 (12.95)	462 (18.19)	510 (20.08)	450 (17.72)		
Length 4	428 (16.85)	562 (22.12)	610 (24.01)	550 (21.65)	350 bar	

Pressure Drop Curves

With 3.5 bar bypass the recommended initial pressure drop is max 1.2 bar.

If the medium used has a viscosity different from 30 cSt, pressure drop over the filter can be estimated as follows:

The total $\Delta p = \text{housing } \Delta p_h + (\text{element } \Delta p_e \times \text{working viscosity}/30)$.

70 Series Empty Housing

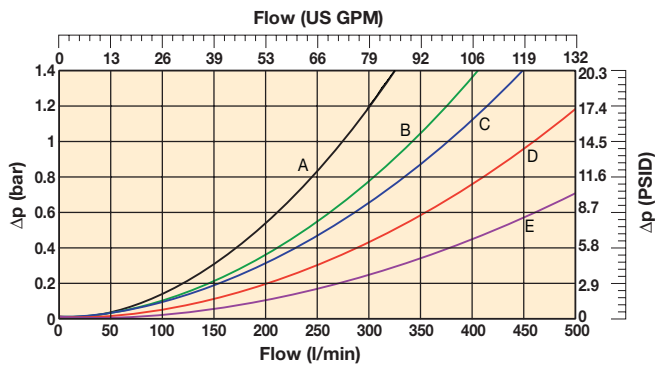

- A: 70T with G16 connections
- B: 70T with G20 connections
- C: 70L with G16 connections
- D: 70T with G20 connections
- E: 70L with G24 connections

70-1 Elements with Microglass III

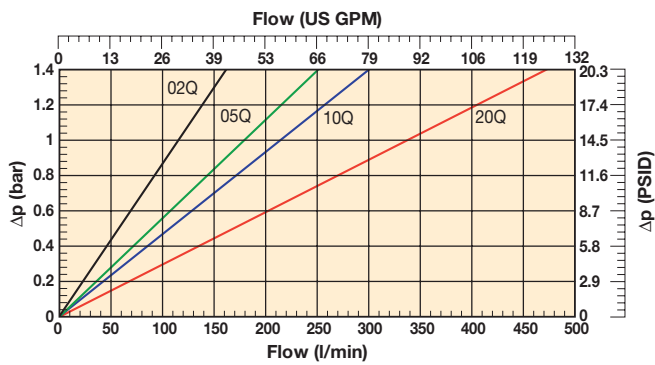

70-2 Elements with Microglass III

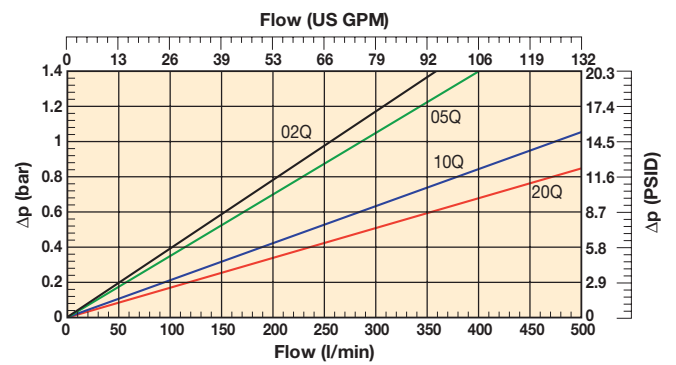

70-3 Elements with Microglass III

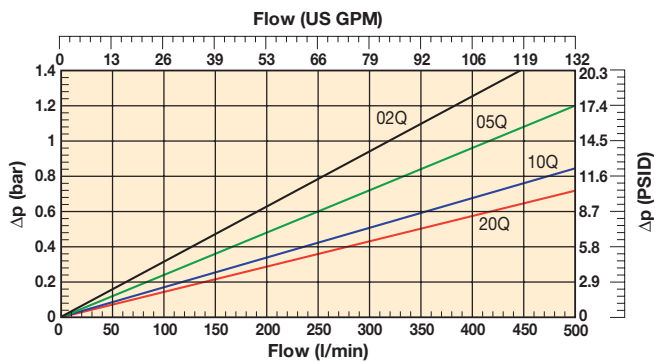

70-4 Elements with Microglass III

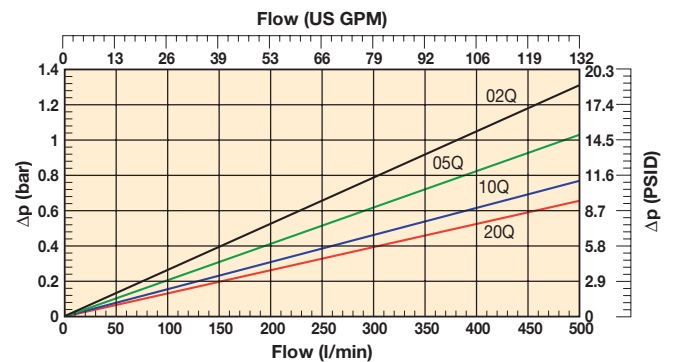

70/70 Eco Series

Pressure Drop Curves (cont.)

70-1 Elements with Ecoglass III

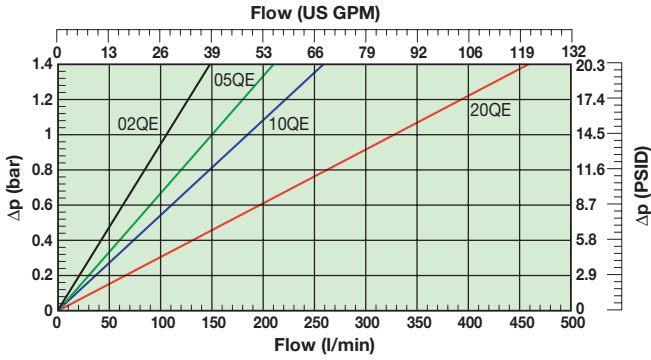

70-2 Elements with Ecoglass III

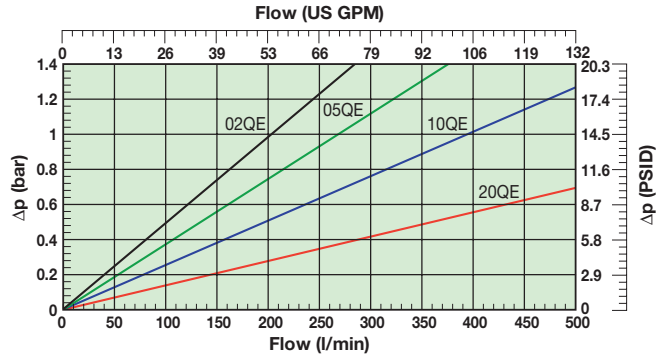

70-3 Elements with Ecoglass III

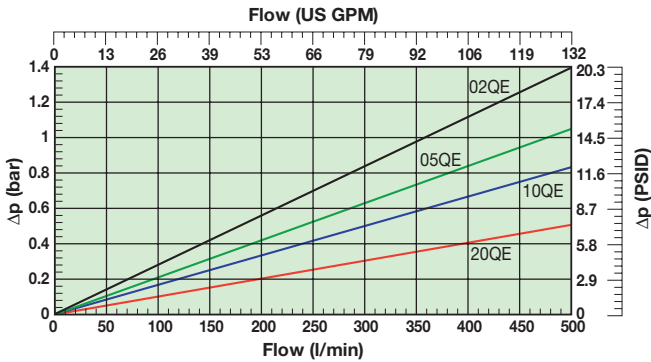

70-4 Elements with Ecoglass III

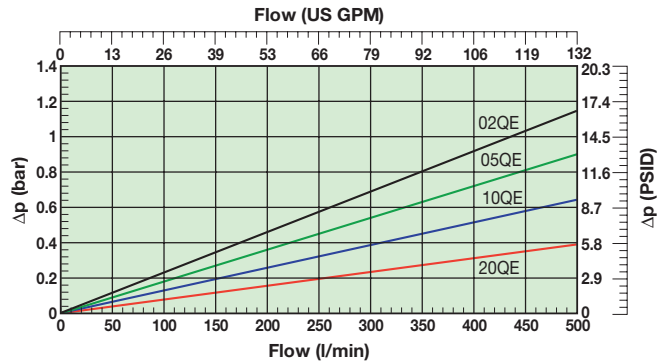

Ordering Information

Standard products table

Part number	Supersedes	Flow (l/min)	Model number	Element length	Media rating (µ)	Seals	Indicator	Bypass settings	Ports	Replacement elements	Supersedes
70L110QBPKG161	FF7005.Q010.BS35.GL16	150	70L	1	10	Nitrile	Plugged	3.5 bar	G1"	938773Q	FC7005.Q010.BK
70L120QBPKG161	FF7005.Q020.BS35.GL16	230	70L	1	20	Nitrile	Plugged	3.5 bar	G1"	938774Q	FC7005.Q020.BK
70L210QBPKG201	FF7006.Q010.BS35.GL20	280	70L	2	10	Nitrile	Plugged	3.5 bar	G1 1/4"	938777Q	FC7006.Q010.BK
70L220QBPKG201	FF7006.Q020.BS35.GL20	300	70L	2	20	Nitrile	Plugged	3.5 bar	G1 1/4"	938778Q	FC7006.Q020.BK
70L310QBPKG241	FF7007.Q010.BS35.GL24	400	70L	3	10	Nitrile	Plugged	3.5 bar	G1 1/2"	938781Q	FC7007.Q010.BK
70L320QBPKG241	FF7007.Q020.BS35.GL24	430	70L	3	20	Nitrile	Plugged	3.5 bar	G1 1/2"	938782Q	FC7007.Q020.BK
70L410QBPKG241	FF7008.Q010.BS35.GL24	430	70L	4	10	Nitrile	Plugged	3.5 bar	G1 1/2"	938785Q	FC7008.Q010.BK
70L420QBPKG241	FF7008.Q020.BS35.GL24	450	70L	4	20	Nitrile	Plugged	3.5 bar	G1 1/2"	938786Q	FC7008.Q020.BK
70L110QEBPKG161	FF7005.QE10.BS35.GL16	150	70L	1	10	Nitrile	Plugged	3.5 bar	G1"	938789Q	FC7005.QE10.BK
70L120QEBPKG161	FF7005.QE20.BS35.GL16	230	70L	1	20	Nitrile	Plugged	3.5 bar	G1"	938790Q	FC7005.QE20.BK
70L210QEBPKG201	FF7006.QE10.BS35.GL20	280	70L	2	10	Nitrile	Plugged	3.5 bar	G1 1/4"	938793Q	FC7006.QE10.BK
70L220QEBPKG201	FF7006.QE20.BS35.GL20	300	70L	2	20	Nitrile	Plugged	3.5 bar	G1 1/4"	938794Q	FC7006.QE20.BK
70L310QEBPKG241	FF7007.QE10.BS35.GL24	400	70L	3	10	Nitrile	Plugged	3.5 bar	G1 1/2"	938797Q	FC7007.QE10.BK
70L320QEBPKG241	FF7007.QE20.BS35.GL24	430	70L	3	20	Nitrile	Plugged	3.5 bar	G1 1/2"	938798Q	FC7007.QE20.BK
70L410QEBPKG241	FF7008.QE10.BS35.GL24	430	70L	4	10	Nitrile	Plugged	3.5 bar	G1 1/2"	938801Q	FC7008.QE10.BK
70L420QEBPKG241	FF7008.QE20.BS35.GL24	450	70L	4	20	Nitrile	Plugged	3.5 bar	G1 1/2"	938802Q	FC7008.QE20.BK
70T110QBPKG161	FF7005.Q010.BS35.GT16	150	70T	1	10	Nitrile	Plugged	3.5 bar	G1"	938773Q	FC7005.Q010.BK
70T120QBPKG161	FF7005.Q020.BS35.GT16	200	70T	1	20	Nitrile	Plugged	3.5 bar	G1"	938774Q	FC7005.Q020.BK
70T210QBPKG201	FF7006.Q010.BS35.GT20	260	70T	2	10	Nitrile	Plugged	3.5 bar	G1 1/4"	938777Q	FC7006.Q010.BK
70T220QBPKG201	FF7006.Q020.BS35.GT20	280	70T	2	20	Nitrile	Plugged	3.5 bar	G1 1/4"	938778Q	FC7006.Q020.BK
70T310QBPKG241	FF7007.Q010.BS35.GT24	360	70T	3	10	Nitrile	Plugged	3.5 bar	G1 1/2"	938781Q	FC7007.Q010.BK
70T320QBPKG241	FF7007.Q020.BS35.GT24	380	70T	3	20	Nitrile	Plugged	3.5 bar	G1 1/2"	938782Q	FC7007.Q020.BK
70T410QBPKG241	FF7008.Q010.BS35.GT24	360	70T	4	10	Nitrile	Plugged	3.5 bar	G1 1/2"	938785Q	FC7008.Q010.BK
70T420QBPKG241	FF7008.Q020.BS35.GT24	380	70T	4	20	Nitrile	Plugged	3.5 bar	G1 1/2"	938786Q	FC7008.Q020.BK
70T110QEBPKG161	FF7005.QE10.BS35.GT16	150	70T	1	10	Nitrile	Plugged	3.5 bar	G1"	938789Q	FC7005.QE10.BK
70T120QEBPKG161	FF7005.QE20.BS35.GT16	200	70T	1	20	Nitrile	Plugged	3.5 bar	G1"	938790Q	FC7005.QE20.BK
70T210QEBPKG201	FF7006.QE10.BS35.GT20	260	70T	2	10	Nitrile	Plugged	3.5 bar	G1 1/4"	938793Q	FC7006.QE10.BK
70T220QEBPKG201	FF7006.QE20.BS35.GT20	280	70T	2	20	Nitrile	Plugged	3.5 bar	G1 1/4"	938794Q	FC7006.QE20.BK
70T310QEBPKG241	FF7007.QE10.BS35.GT24	360	70T	3	10	Nitrile	Plugged	3.5 bar	G1 1/2"	938797Q	FC7007.QE10.BK
70T320QEBPKG241	FF7007.QE20.BS35.GT24	380	70T	3	20	Nitrile	Plugged	3.5 bar	G1 1/2"	938798Q	FC7007.QE20.BK
70T410QEBPKG241	FF7008.QE10.BS35.GT24	360	70T	4	10	Nitrile	Plugged	3.5 bar	G1 1/2"	938801Q	FC7008.QE10.BK
70T420QEBPKG241	FF7008.QE20.BS35.GT24	380	70T	4	20	Nitrile	Plugged	3.5 bar	G1 1/2"	938802Q	FC7008.QE20.BK

Note: Filter assemblies ordered from the product configurator on next page are on extended lead times. Where possible, please make your selection from the table above.

70/70 Eco Series

Ordering Information (cont.)

Product configurator

Box 1	Box 2	Box 3	Box 4	Box 5	Box 6	Box 7	Box 8
70L	3	10Q	B	M3	K	G24	1

Box 1		Box 2		Box 3					
Code		Filter type		Degree of filtration					
Model	Code	Length	Code	Element media	Glass fibre				
High pressure filter with L-port	70L	Length 1	1		2µ media	5µ media	10µ media	20µ media	
High pressure filter with T-port	70T	Length 2	2	Microglass III element	02Q	05Q	10Q	20Q	
High pressure filter with side manifold mounting	70B	Length 3	3	Ecoglass III element	02QE	05QE	10QE	20QE	
		Length 4	4	High collapse element	02QH	05QH	10QH	20QH	

Note: When using Ecoglass III elements reusable Eco-adaptor is required

Box 4		Box 5		Box 6		
Seal type		Indicator		Bypass and indicator settings		
Seal material	Code		Code	Bypass valve	Indicator	Code
Nitrile	B	Plugged with steel plug	P	3.5 bar	2.5 bar	K
Fluoroelastomer	V	Visual indicator	M3	No bypass	7.0 bar	N
		Electrical indicator	T1	No bypass	No indicator (P)	X
		Electronic 4 LED, PNP, N.O.	F1	+ Box 8: code 2		
		Electronic 4 LED, NPN, N.O.	F2	+ Box 8: code 2		
		Electronic 4 LED, PNP, N.C.	F3			
		Electronic 4 LED, NPN, N.C.	F4			

When filter includes a bypass valve but not an indicator, code denotes bypass setting.

Box 7					
Filter connection					
Connections	Code	Length 1	Length 2	Length 3	Length 4
Thread G 1	G16	S	S	x	x
Thread G 1 1/4	G20	S	S	S	S
Thread G 1 1/2	G24	x	S	S	S
SAE flange 1 1/4" 3000-M	R20	x	x	x	x
SAE flange 1 1/2" 3000-M	R24	x	x	x	x
SAE flange 1 1/4" 6000-M	H20	x	x	x	x
SAE flange 1 1/2" 6000-M	H24	x	x	x	x
Side manifold (70B only)	X32	x	x	x	x

Availability: **S** = standard product
x = non-standard, ask for availability

Box 8	
Options	
Options	Code
Standard	1
No bypass	2
70T: side indicator ports	6
70T: options 2 + 6	8

Options 6 and 8: in 70T model there is an option for 2 x indicator ports on filter outlet flange (standard indicator port not machined)
P: both side indicator ports plugged with steel plug
M3 or other indicator chosen: right side (in flow direction) port plugged with a plastic plug, left with a steel plug

Nominal flow (l/min) at viscosity 30 cSt							
Filter length	Media	G16 L-port & G20 T-port		G20 L-port & Side manifold		G24 T-port & G24 L-port	
		G16 L-port & G20 T-port	G20 L-port & Side manifold	G20 L-port & Side manifold	G24 T-port	G24 L-port	
Length 1	02Q/02QE	80	80	80	80	80	80
	05Q/05QE	120	120	120	120	120	120
	10Q/10QE	150	150	150	150	150	150
	20Q/20QE	200	230	230	230	230	230
Length 2	02Q/02QE	160	160	160	160	160	160
	05Q/05QE	180	200	200	200	200	200
	10Q/10QE	220	260	280	300	320	320
	20Q/20QE	240	280	300	330	350	350
Length 3	02Q/02QE	200	220	220	220	220	220
	05Q/05QE	220	250	280	280	280	280
	10Q/10QE	240	280	300	350	400	400
	20Q/20QE	250	300	320	380	430	430
Length 4	02Q/02QE	220	250	270	270	270	270
	05Q/05QE	230	260	300	330	330	330
	10Q/10QE	250	280	330	360	430	430
	20Q/20QE	260	300	350	380	450	450

Replacement elements with nitrile seals				
Media	Length 1	Length 2	Length 3	Length 4
02Q	938771Q	938775Q	938779Q	938783Q
05Q	938772Q	938776Q	938780Q	938784Q
10Q	938773Q	938777Q	938781Q	938785Q
20Q	938774Q	938780Q	938782Q	938786Q
02QE	938787Q	938791Q	938795Q	938799Q
05QE	938788Q	938792Q	938796Q	938800Q
10QE	938789Q	938793Q	938797Q	938801Q
20QE	938790Q	938794Q	938798Q	938802Q
02QH	938803Q	938807Q	938811Q	938815Q
05QH	938804Q	938808Q	938812Q	938816Q
10QH	938805Q	938809Q	938813Q	938817Q
20QH	938806Q	938810Q	938814Q	938818Q

Highlights Key (Denotes part number availability)

123	Item is standard
123	Item is standard with "green" options
123	Item is semi standard
123	Item is non standard

Note: Standard items are in stock, semi standard items are available within four weeks

Degree of filtration						Code		
Average filtration beta β (ISO 16889) / particle size µm [c]						Disposible Microglass III	Metal free Ecoglass III	High collapse element
βx(c)=2	βx(c)=10	βx(c)=75	βx(c)=100	βx(c)=200	βx(c)=1000			
% efficiency, based on the above beta ratio (βx)								
50.0%	90.0%	98.7%	99.0%	99.5%	99.9%	02Q	02QE	02QH
N/A	N/A	N/A	N/A	N/A	4.5	05Q	05QE	05QH
N/A	N/A	4.5	5	6	7	10Q	10QE	10QH
N/A	6	8.5	9	10	12	20Q	20QE	20QH
6	11	17	18	20	22			

Note 1: Part numbers featured with bold highlighted codes will ensure a 'standard' product selection.
Note 2: Alternate displayed part number selection will require you to contact Parker Filtration for availability.

High Pressure Duplex Filters

22PD/32PD Series

MAX 260 l/min - 210 bar



High Pressure Duplex Filters

22PD/32PD Series

Features & Benefits

Features	Advantages	Benefits
Duplex design	Element service possible during operation	Allows to keep machine running with full contamination protection
Integrated balancing valve	No external piping required	Safety and reliability
Vent ports	Purges all trapped air in filter	Get the maximum performance from the elements Prevents a "flabby" system
Microglass III replacement elements	Multi-layered design produced high capacity and efficiency	Great performance value Reliable performance throughout element life
	Wire support reduces pleat bunching, keeps performance consistent	Reduces downtime, maximises element life
Visual, electrical and electronic indicators available	Check element condition at a glance	Optimises element life, prevents bypassing
	Right style for the application	Matches your system electrical connections

Typical Applications

- Ship steering systems
- Continuous operation industrial systems
- High flow flushing systems

The Parker Filtration 22PD/32PD Series High Pressure Duplex Filters.

Specially designed to offer continuous operation, even during element change.

A changeover valve operates on the upstream side of the filter, ensuring a contamination free system.



Specification

Pressure ratings:

Maximum allowable operating pressure 210 bar.
Filter housing pressure pulse fatigue tested: 10⁶ cycles 210 bar.

Connections:

Inlet and outlet connections are threaded.

Connection style	Model	
BSPF(G)	22PD	32PD
Flange SAE 3000-M	1" 1/4"	1 1/2"

*3000-M is a SAE style with appropriate metric fixing threads.

Filter housing:

Head material cast iron (GSI).
Bowl material steel.

Seal material:

Nitrile or Fluoroelastomer.

Operating temperature range:

-20°C to +100°C.

Bypass valve:

Opening pressure 3.5 bar

Filter element:

Degree of filtration:

Determined by multipass-test according to ISO 16889, see Box 3 in the product configurator.

Flow fatigue characteristics:

Filter media is supported so that the optimal fatigue life is achieved (ISO 3724).

Microglass III:

Supported with epoxy coated metal wire mesh, end cap material reinforced composite and metal inner core. Collapse rating 20 bar (ISO 2941).

High collapse elements:

(to be used when no bypass function in filter housing).
Microglass III media supported with epoxy coated metal wire mesh on upstream and stainless steel on downstream, end cap material steel. Strong metal inner core. Collapse rating 210 bar (ISO 2941).

Indicator options:

Indicating differential pressure: 2.5 ± 0.2 bar.

- visual M3.
- electrical T1.
- electronic F1 (PNP).
- electronic F2 (NPN).

For indicator details see catalogue section 6.

Weights (kg):

Model	Length 1	Length 2
22PD	22	27
32PD	44	50

Fluid compatibility:

Suitable for use with mineral and vegetable oils, and some synthetic oils. For other fluids, please consult Parker Filtration.

Dimensions mm (inches)

Model	A	B	C	D	E	F	G	H	I	J	K	L	M	N
22PD-1	240	35	92	18	55	150	150	96	192	60	30	59	30.75Ø	236 (9.29)
22-PD-2	(9.45)	(1.38)	(3.62)	(0.71)	(2.16)	(5.91)	(5.90)	(3.70)	(7.56)	(2.36)	(1.18)	(2.32)		345 (13.58)
32PD-1	306	42	130	20	78	170	165	120	240	75	36	70	38Ø	317 (12.48)
32PD-2	(12.05)	(1.65)	(5.12)	(0.79)	(3.07)	(6.69)	(6.49)	(4.72)	(9.45)	(2.95)	(1.42)	(2.75)		437 (17.20)

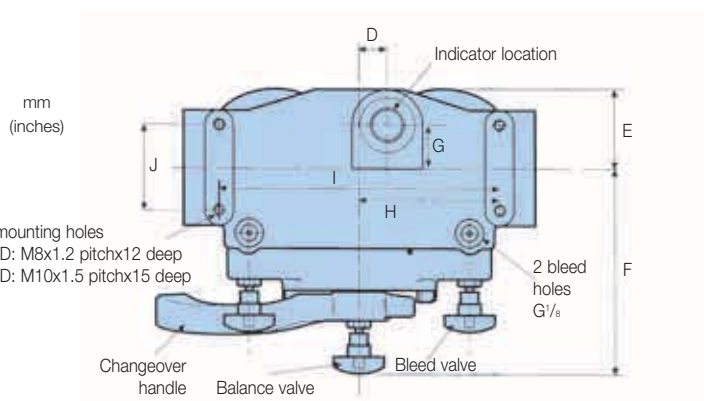
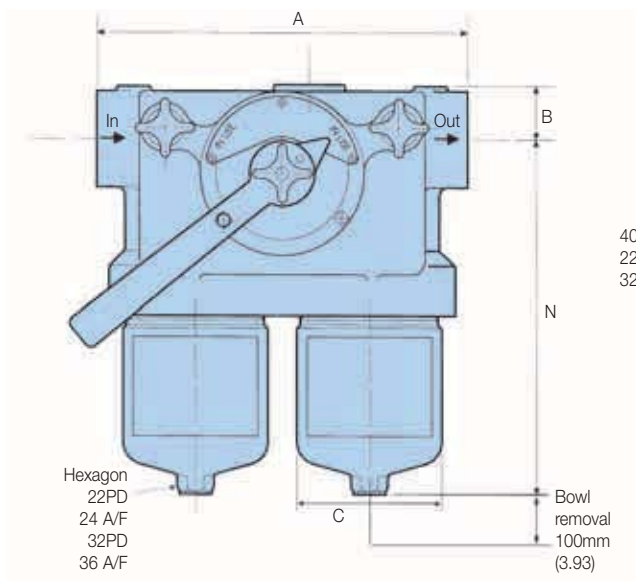

Flange face detail

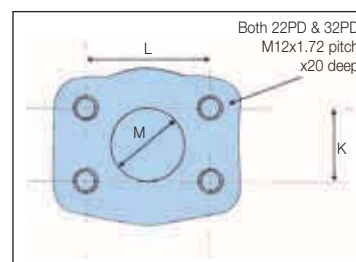

22PD/32PD Series

Pressure Drop Curves

The recommended level of initial pressure drop is max. 1.2 bar.

If the medium used has a viscosity different from 30 cSt, pressure drop over the filter can be estimated as follows:

$$\Delta p = (\Delta p_{30} \times \text{viscosity of medium used}) / 30 \text{ cSt.}$$

The total Δp = housing Δp + (element $\Delta p_e \times \text{working viscosity}/30$).

22PD/32PD Bypass Valve

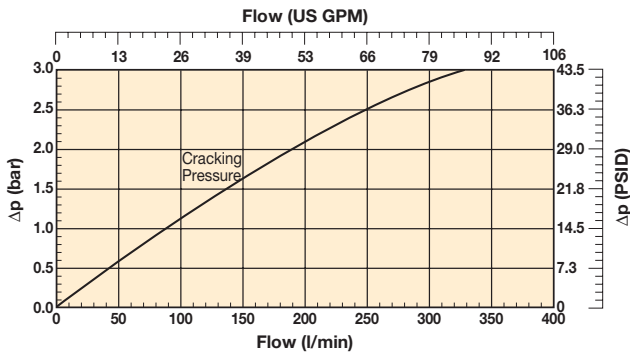

22PD/32PD Empty Housing

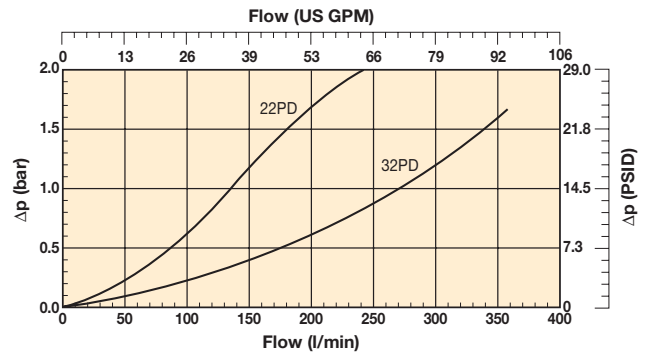

22PD-1 Elements

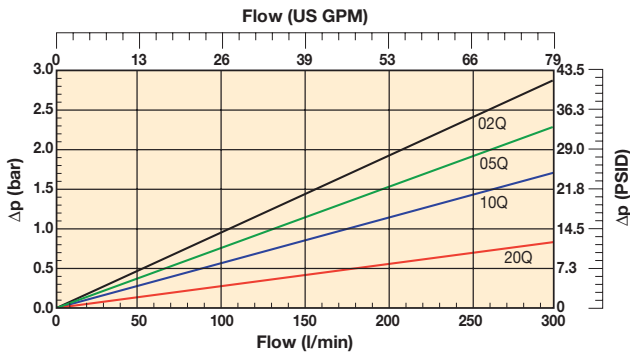

22PD-2 Elements

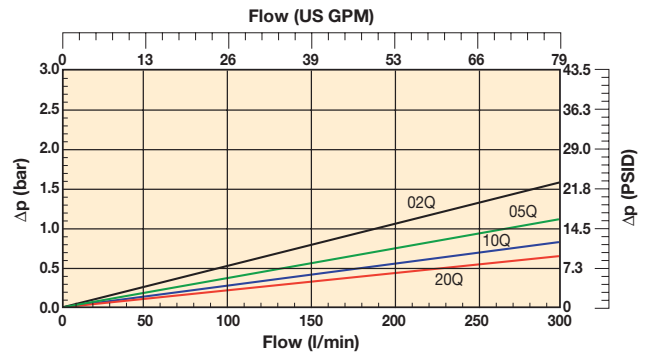

32PD-1 Elements

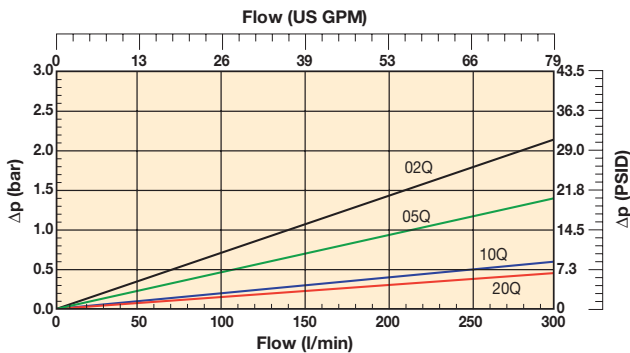

32PD-2 Elements

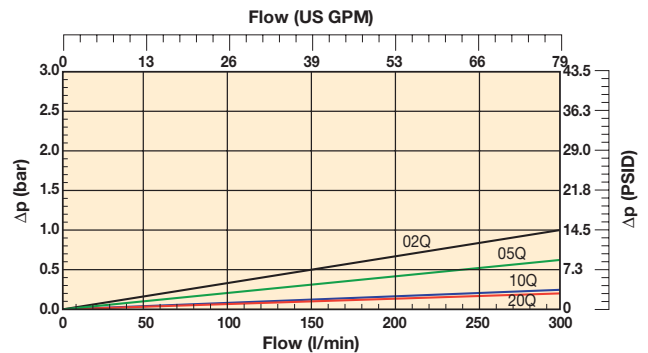

22PD-1 High Collapse Elements

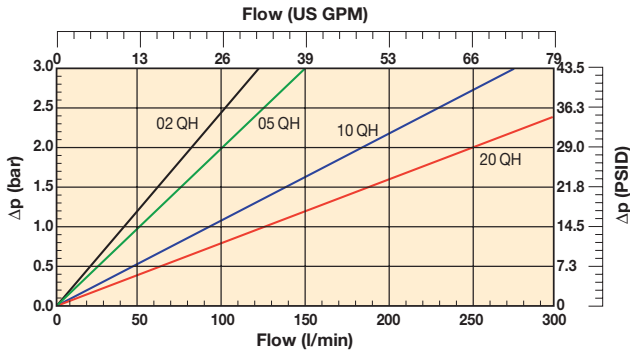

22PD-2 High Collapse Elements

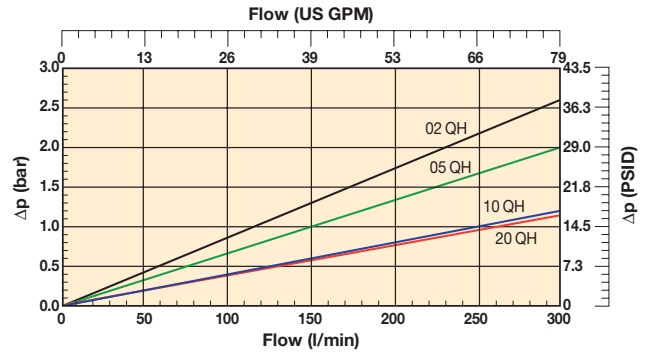

32PD-1 High Collapse Elements

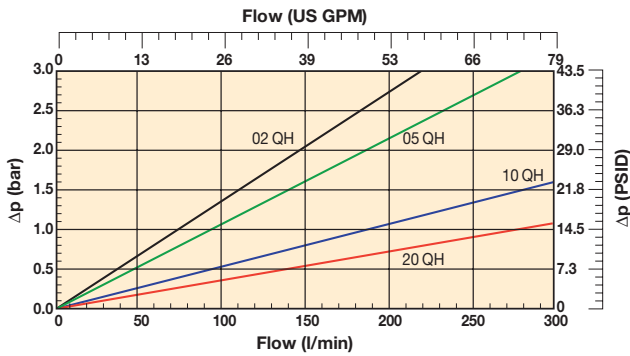

32PD-2 High Collapse Elements

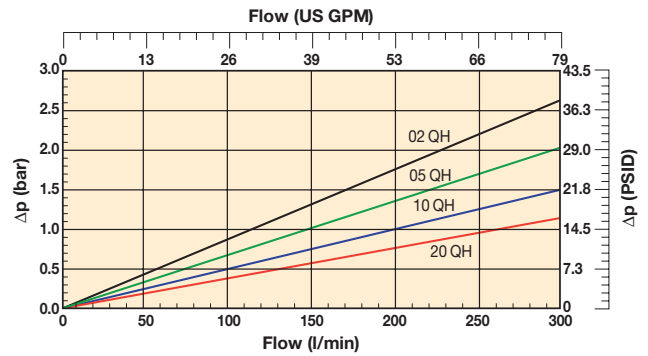

Ordering Information

Standard products table

Part number	Supersedes	Flow (l/min)	Model number	Element length	Media rating (μ)	Seals	Indicator	Bypass settings	Ports	Replacement elements
22PD210QBM3KG161	0-22-PD-2-10Q-V-50-C-1	120	22PD	Length 2	10	Nitrile	Visual	3.5 bar	G1"	G01315Q
22PD210QBT1KG161	0-22-PD-2-10Q-TW3-50-C-1	120	22PD	Length 2	10	Nitrile	Electrical	3.5 bar	G1"	G01315Q
22PD220QBM3KG161	0-22-PD-2-20Q-V-50-C-1	140	22PD	Length 2	20	Nitrile	Visual	3.5 bar	G1"	G01938Q
22PD220QBT1KG161	0-22-PD-2-20Q-TW3-50-C-1	140	22PD	Length 2	20	Nitrile	Electrical	3.5 bar	G1"	G01938Q
32PD210QBM3KG201	0-32-PD-2-10Q-V-50-D-1	240	32PD	Length 2	10	Nitrile	Visual	3.5 bar	G1 1/2"	G01098Q
32PD210QBT1KG201	0-32-PD-2-10Q-TW3-50-D-1	240	32PD	Length 2	10	Nitrile	Electrical	3.5 bar	G1 1/2"	G01098Q
32PD220QBM3KG201	0-32-PD-2-20Q-V-50-D-1	260	32PD	Length 2	20	Nitrile	Visual	3.5 bar	G1 1/2"	G01954Q
32PD220QBT1KG201	0-32-PD-2-20Q-TW3-50-D-1	260	32PD	Length 2	20	Nitrile	Electrical	3.5 bar	G1 1/2"	G01954Q

Note: Filter assemblies ordered from the product configurator on the next page are on extended lead times. Where possible, please make your selection from the table above.

High Pressure Duplex Filters

22PD/32PD Series

Ordering Information (cont.)

Product configurator

Box 1 22PD	Box 2 2	Box 3 10Q	Box 4 B	Box 5 M3	Box 6 K	Box 7 G16	Box 8 1
----------------------	-------------------	---------------------	-------------------	--------------------	-------------------	---------------------	-------------------

Box 1

Code	
Model	Code
Small high pressure duplex filter	22PD
Large high pressure duplex filter	32PD

Box 2

Filter type	
Length	Code
Length 1	1
Length 2	2

Box 3

Degree of filtration				
Element media	Glass fibre			
	2µ media	5µ media	10µ media	20µ media
Microglass III element	02Q	05Q	10Q	20Q
High collapse element	02QH	05QH	10QH	20QH

Box 4

Seal type	
Seal material	Code
Nitrile	B
Fluoroelastomer	V

Box 5

Indicator	
	Code
Visual indicator	M3
Electrical indicator	T1
Plugged with steel plug	P
No indicator port	N
Electronic 4 LED, PNP, N.O.	F1
Electronic 4 LED, NPN, N.O.	F2
Electronic 4 LED, PNP, N.C.	F3
Electronic 4 LED, NPN, N.C.	F4

Box 6

Bypass and indicator settings		
Bypass valve	Indicator	Code
3.5 bar	2.5 bar	K
No bypass	5.0 bar	M
No bypass	No indicator	X

+ Box 8: code 2
+ Box 8: code 2

When filter includes a bypass valve but not an indicator, code denotes bypass setting.

Box 7

Filter connection	
Ports	Code
22PD: Thread G 1	G16
SAE flange 1 1/4" 3000-M	R20
32PD: Thread G 1 1/4	G20
SAE flange 1 1/2" 3000-M	R24

Box 8

Options	
Options	Code
Standard	1
No bypass	2

Replacement elements with nitrile seals				
Media	22PD-1	22PD-2	32PD-1	32PD-2
02Q	G01282Q	G01316Q	G01069Q	G01099Q
05Q	G02721Q	G02724Q	G02567Q	G02727Q
10Q	G01281Q	G01315Q	G01068Q	G01098Q
20Q	G01930Q	G01938Q	G01946Q	G01954Q
02QH	G01442Q	G01448Q	G01454Q	G01460Q
05QH	G03737Q	G03738Q	G03739Q	G03740Q
10QH	G01441Q	G01447Q	G01453Q	G01459Q
20QH	G01932Q	G01940Q	G01948Q	G01956Q

Nominal flow (l/min) at viscosity 30 cSt				
Filter model	02Q	05Q	10Q	20Q
22PD-1	70	80	100	120
22PD-2	100	110	120	140
32PD-1	100	150	210	230
32PD-2	180	210	240	260

Seal kits		
Filter model	Nitrile	Fluoroelastomer
22PD	S04233	S04234
32PD	S02373	S02375

Replacement elements with fluoroelastomer seals				
Media	22PD-1	22PD-2	32PD-1	32PD-2
02Q	G01302Q	G01336Q	G01089Q	G01119Q
05Q	G02723Q	G02726Q	G02569Q	G02729Q
10Q	G01301Q	G01335Q	G01088Q	G01118Q
20Q	G01934Q	G01942Q	G01950Q	G01958Q
02QH	G01446Q	G01452Q	G01458Q	G01464Q
05QH	G04235Q	G04236Q	G04237Q	G04238Q
10QH	G01445Q	G01451Q	G01457Q	G01463Q
20QH	G01935Q	G01943Q	G01951Q	G01959Q

Highlights Key (Denotes part number availability)

123	Item is standard
123	Item is standard with "green" options
123	Item is semi standard
123	Item is non standard

Note: Standard items are in stock, semi standard items are available within four weeks

Degree of filtration						Code	
Average filtration beta ratio β (ISO 16889) / particle size µm [c]							
β(x)=2	β(x)=10	β(x)=75	β(x)=100	β(x)=200	β(x)=1000	Disposable Microglass III	High collapse element
% efficiency, based on the above beta ratio (βx)							
50.0%	90.0%	98.7%	99.0%	99.5%	99.9%		
N/A	N/A	N/A	N/A	N/A	4.5	02Q	02QH
N/A	N/A	4.5	5	6	7	05Q	05QH
N/A	6	8.5	9	10	12	10Q	10QH
6	11	17	18	20	22	20Q	20QH

Note 1: Part numbers featured with bold highlighted codes will ensure a 'standard' product selection.

Note 2: Alternate displayed part number selection will require you to contact Parker Filtration for availability.