



aerospace  
climate control  
electromechanical  
filtration  
fluid & gas handling  
hydraulics  
pneumatics  
process control  
sealing & shielding



# Fluid Condition Monitoring and Fuel Hydrocarbon Monitoring Solutions



ENGINEERING YOUR SUCCESS.



- Consistent quality
- Technical innovation
- Premier customer service

Parker's technical resources provide the correct filtration technologies that conform to your requirements. That's why thousands of manufacturers and equipment users around the world rely on Parker Filtration products and people.

## Worldwide Sales and Service

Parker Filtration's global reputation as a reliable supplier of superior filtration products is the result of a focused and integrated development and manufacturing system.

Parker Filtration consolidates quality filtration products, manufactured by process filtration, air and gas filtration and separation, fuel conditioning and filtration, hydraulic and lubrication filtration, fluid power products and fluid condition monitoring equipment into one broad-based range that covers many markets and most applications, as detailed here.

### Hydraulic, Lubrication & Coolant Filtration

High-performance filtration systems for production machinery in industrial, mobile and military/marine applications.



### Compressed Air & Gas Filtration

Complete line of compressed air/gas filtration products; coalescing, particulate and adsorption filters in many applications in many industries.



Photo courtesy of GLASBAU HAHN.

### Process & Chemical Fluid Filtration

Liquid filtration systems for beverage, chemical and food processing; cosmetic, paint, water treatment; photo-processing; and micro-chip fabrication.



### Racor Fuel Conditioning & Filtration

Parker air, fuel and oil filtration systems provide quality protection for engines operating in any environment, anywhere in the world.



### System Contamination Monitoring

On-line dynamic particle analysis, off-line bottle sampling and fluid analysis and measurement of water content polluting the oil in a system. All important and achievable, cost-effective solutions available to equipment manufacturers and end users alike.



# Contents

## Fluid Condition Monitoring and Contamination Control

### Introduction

Working with equipment manufacturers, hydraulic system designers and maintenance engineers, one of the key factors for Parker Filtration's Condition Monitoring and Contamination Control Division relates to the environment. It has been made abundantly clear that our top priority has to be energy conservation and pollution control.

System efficiency, reduced downtime and predictive maintenance are all components that play a significant role in our customers being able to more efficiently manage their hydraulic applications and systems and maintaining peak power and efficiency of those systems. In the field of fluid contamination monitoring, the laser has become a key component in the monitoring of systems where OEM's and end users alike are evaluating system cleanliness and filtration effectiveness with condition monitoring analysis and data logging of results.

As a leading manufacturer and design authority of portable particle analysers, we are justifiably proud of the developments we have made over recent years. At Parker's Condition Monitoring Centre, located at Thetford in the East of England we are particularly proud that we have been able to play our part in the hydraulic fluids and fuel industries, where our Condition Monitoring equipment provides accurate indications of filtration efficiency and system cleanliness levels.

### Fluid condition monitoring

LaserCM Contamination Monitor	3
Universal Bottle Sampler	11
Single Point Sampler	17
System 20 Sensors and Monitors	21
MCM20 Autoremove Monitor	27
Icount PD Particle Detector	31
H <sub>2</sub> Oil – Water in Oil Monitor	41
Moisture Sensor Range	45
Oilcheck Monitor	53

### Transducers & transmitters

Asic 'Performer'	57
------------------	----

### Fuel Hydrocarbon Monitoring

ACM20 Lab Unit	61
ACM20 Z2 Particle Counter (ATEX Approved)	69



# Important changes to our product ordering information

## Standard Product Tables and a Product Configurator

Parker Filtration has recently undertaken a review of its part numbering with a view to standardising on a common part number style for all Filtration products. As a result of the many acquisitions we have made over the past 10 years, it became clear to us that there was a need to standardise on a clear format for our part numbers.

Accordingly, in this new catalogue, you will find the new part number system with both a configurator and a supersedes cross reference relating to previous part numbers, issued in earlier editions of our generic catalogues. In the event that the previous reference you use is not shown in this catalogue, could we ask you to please contact our European Product Information Centre. Contact details are on the back of this catalogue.

The examples below using the BGT Series Ordering Information, are included to explain how the Standard products are presented in the Ordering Information section of the catalogue and also how the new Product Configurator works.

### Explanation

#### Example 1. The Standard Products Table

We have created a new catalogue ordering code and included in this table are details of these new part numbers.

Alongside this we have put the part number that has been superseded from previous catalogues. It is our intention that all items printed in the **Standard Products Table** will be available from our central warehouse for ex-stock delivery.

#### Example 2. The Product Configurator

2a. As part of our new catalogue ordering code we have introduced an **8-box part number configurator**. This

configurator features items, which are marked in **bold** and are on a shortened delivery time. With this in mind we would ask that when making a selection using the configurator you select those items in bold to ensure the shortest lead-time.

2b. The configurator has been designed to cover not only the various models we offer but also different micron ratings, indicator options and port connections.

2c. Should you find that what you have selected is not available in the configurator, please feel free to call our European Product Information Centre (EPIC) to see if that option can be made available. Contact details are available on the back of this catalogue.

### Green shaded graphs and ordering information

Where pressure drop graphs and ordering information are shown with a green tint, these options are 'Eco' options and environmentally friendly.

Example 1. The Standard Products Table

Part number	Supersedes	Flow (l/min)	Model number	Element length	Media rating (µ)	Seals	Indicator	Bypass settings	Ports	Included options	Replacement elements	Supersedes
<b>BGT121QOLBPER323</b>	BGT5500-S2 TWML8C-10 T B15 M	500	BGT5500	Length 12	10	Nitrile	Plugged	1.5 Bar (22 Psi)	2"SAE-3000 PSI	Diffuser type T	<b>937850Q</b>	TXWLL-10
<b>BGT122QOLBPER323</b>	BGT5500-S2 TWML8C-20 T B15 M	500	BGT5500	Length 12	20	Nitrile	Plugged	1.5 Bar (22 Psi)	2"SAE-3000 PSI	Diffuser type T	<b>937860Q</b>	TXWLL-20
<b>BGT151QOLBPER483</b>	BGT1000-S3 TWML12-10 T B15 M	1000	BGT1000	Length 15	10	Nitrile	Plugged	1.5 Bar (22 Psi)	3"SAE-3000 PSI	Diffuser type T	<b>937860Q</b>	TXWLL-10
<b>BGT152QOLBPER483</b>	BGT1000-S3 TWML12-20 T B15 M	1000	BGT1000	Length 15	20	Nitrile	Plugged	1.5 Bar (22 Psi)	3"SAE-3000 PSI	Diffuser type T	<b>937860Q</b>	TXWLL-20
<b>BGT171QOLBPER483</b>	BGT2000-S3 TWML14-10 T B15 M	2000	BGT2000	Length 17	10	Nitrile	Plugged	1.5 Bar (22 Psi)	3"SAE-3000 PSI	Diffuser type T	<b>937720Q</b>	TXW14-10B
<b>BGT172QOLBPER483</b>	BGT2000-S3 TWML14-20 T B15 M	2000	BGT2000	Length 17	20	Nitrile	Plugged	1.5 Bar (22 Psi)	3"SAE-3000 PSI	Diffuser type T	<b>937800Q</b>	TXW14-20B

Note: Filter assemblies ordered from the product configurator below are on extended lead times. Where possible, please make your selection from the table above.

Example 2. The Product Configurator

Configurator examples filter including LEIP® element

Box 1	Box 2	Box 3	Box 4	Box 5	Box 6	Box 7	Box 8
<b>BGT</b>	<b>15</b>	<b>05QL</b>	<b>B</b>	<b>S1</b>	<b>E</b>	<b>R48</b>	<b>C</b>

Configurator examples filter including conventional element

Box 1	Box 2	Box 3	Box 4	Box 5	Box 6	Box 7	Box 8
<b>BGT</b>	<b>18</b>	<b>02Q</b>	<b>B</b>	<b>S4</b>	<b>E</b>	<b>3R20</b>	<b>4</b>

Code	Filter type	Degree of filtration
<b>BGT</b>	Housing 3-300 l/min 3-500 l/min 4-600 l/min 4-800 l/min 4-1000 l/min 4-1500 l/min 4-2000 l/min 4-2400 l/min	Element Glass fibre Microglass II (for disposable elements) Cellulose Ecoglass III (for LEIP® elements) Wire mesh Abs. rating 040W
	Code 11 12 13 15 16 17 18	Norm. rating 10C 02Q 05Q 05QL 10Q 20Q 20QL

Seal type	Indicator	Bypass valve
Seal material Nitrile Fluorocastomer Noprene	Code B	Code B E H X on request
	Code G1 G2 S1 S2 S3 S4 S5 N P P2 on request	Code B E H X on request

Note: For all dual head ports for BGT's apply G 1/2 connection for indicators

Filter connection	Options
Parts 2" SAE BGT-3 3" SAE BGT-4 1x2" SAE flanged + 2x1/2" SAE flanged for BGT-3 3x1/2" SAE flanges + 1x1/2" SAE for BGT-4	Options No diffuser required Diffuser type T with perforated plate area Diffuser type P without perforated plate area Diffuser with integrated hose connection No magnets Dipstick Plugged filling port Diffuser type T and no magnets Diffuser type P and no magnets Diffuser type T, no magnets, plugged filling port Diffuser type P, no magnets, plugged filling port Other combinations
Code R32 R48 R32M 3R20	Code 1 3 4 on request 5 6 8 A B C D on request

### Highlights Key (Denotes part number availability)

<b>123</b>	Item is standard
<b>123</b>	Item is standard green option
<b>123</b>	Item is semi standard
123	Item is non standard

Note: Standard items are in stock, semi standard items are available within four weeks





Portable Particle Counter

# LaserCM

Fluid Condition Monitoring



# LaserCM

## Features & Benefits

<b>Test time:</b>	2 minutes
<b>Particle counts:</b>	2+, 5+, 15+, 25+, 50+ and 100+ microns 4+, 6+, 14+, 21+, 38+ and 70+ microns(c)
<b>International codes:</b>	ISO 7-22, NAS 0-12
<b>Data retrieval:</b>	Memory access gives test search facility
<b>Max. working pressure:</b>	420 bar
<b>Max. flow rate:</b>	400 l/min when used with system 20 Sensors. Higher with single point sampler (consult Parker)
<b>Working conditions:</b>	LaserCM will operate with the system working normally
<b>Computer compatibility:</b>	Interface via RS232 connection @ 9600 baud rate.

- Special 'diagnostics' are incorporated into the LaserCM microprocessor control to ensure effective testing.
- Routine contamination monitoring of oil systems with LaserCM saves time and saves money.
- Contamination monitoring is now possible while machinery is working - LaserCM saves on production downtime.

- Data entry allows individual equipment test log details to be recorded.
- Data retrieval of test results from memory via hand set display.
- Automatic test cycle logging of up to 300 tests can be selected via hand set display.
- Totally portable, can be used as easily in the field as in the laboratory.
- Automatic calibration reminder.
- Instant, accurate results achieved with a 2 minute test cycle.
- Data entry allows individual equipment footprint record.
- Data graphing selectable via the integral printer.
- Auto 300-test cycle logging via LCD handset input.
- RS232 serial port computer interface.
- Limit level output to control peripheral equipment such as off-line filtration via internal relay limit switches.
- Auto-testing allows for the conducting of automatic sequencing tests on flushing systems for example.
- Optional bar code swipe wand to allow handset data loading.
- Worldwide service and technical support.
- Re-calibration - Annual certification by an approved Parker Service Centre.

## Typical Applications

- Construction machinery
- Industrial plant
- Hydraulic equipment & system manufacturers
- Research & testing institutes
- Offshore & power generation
- Marine
- Military equipment applications

### Parker LaserCM Portable Particle Counter.

With 15 years experience in manufacturing the world's best selling 'white light' portable particle counter – CM20, the progression to the LaserCM with its opto-mechanical, continuous wave single point source laser (SPSL) is both a natural and customer driven development.



## Specification

Automatic Particle Counters (APC's), have been widely used for many years in condition monitoring of hydraulic fluids. However, it is only recently that APC's have become flexible enough to enable the instruments to be taken out of the laboratory and used on-line in order to obtain the most credible form of results.

Unusually, the move from fixed laboratory use, to portable field use has not been at the expense of accuracy or user flexibility, but has actually enabled the instruments to be used over a wider range of applications and situations.

The most common monitoring technique used in APC's is that of light obscuration or light blockage. Here, a focused light source is projected through a moving column of oil, (in which the contaminants being measured are contained), causing an image of the contaminant to be projected on to a photo diode cell, (changing light intensity to an electrical output).

The electrical output of the photo diode cell will vary in accordance with the size of the particles contained in the column of oil; the larger the particle, the bigger the change in the photo diode electrical output.

On-line APC's must be able to test the oil sample at whatever cleanliness it is delivered to the machine. Parker therefore had to develop technology to ensure the on-line APC was able to test a sample without the conventional laboratory technique which requires dilution - a practice that would have been simply impossible with a portable unit.

By careful design and window sizing, gravimetric levels as high as 310mg of dirt per litre, (equivalent to up to 4 million particles >6 micron per 100 ml), can be achieved without making the instrument susceptible to counter saturation.

These high saturation point on-line APC's, whilst losing none of the accuracy of their laboratory counterparts, enable particle counting to be carried out quickly and accurately.



A focused light source is projected through a moving column of oil.

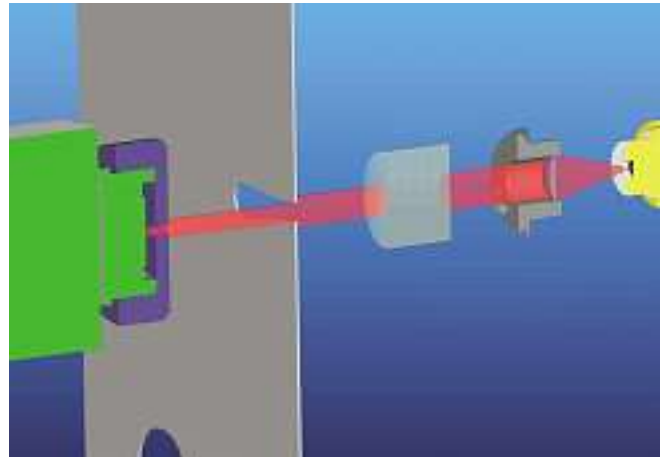

Laser Optical Sensing

### Core technology that proves itself in LaserCM

The LaserCM portable particle counter features microprocessor controlled optical scanning for accurate contaminant measurement with a calibration range from ISO 7 to ISO 22 with no counter saturation.

### How does LaserCM work?

- The particles are measured by a photo diode that converts light intensity to a voltage output which is recorded against time.
- As the particle moves across the window the amount of light lost is proportional to the size of the particle. This reduction in voltage is measured and recorded.
- This "voltage" lost relates directly to the area of the particle measured, is changed into a "positive" voltage and then in turn changed into a capacitance value.
- This value is counted and stored in the LaserCM computer in one of 6 channels according to particle size.
- Readouts are displayed on the hand-held LCD in the accepted ISO and NAS standards ready for hard copy printing or RS232 computer download.
- The on-board computer allows storage of up to 300 test results.

Portable Particle Counter

# LaserCM

## Specification

Description	LaserCM (LCM20 20 22)	LaserCM (LCM20 20 62)
Lexan, structural foam and ABS case	•	•
ABS handheld display	•	•
Mechanical composition – Brass, plated steel, stainless steel and aluminium	•	•
Fluorocarbon seals	•	•
Perfluoroelastomer seals	•	•
Nylon hoses (kevlar braided microbore)	•	•
Stainless steel armoured hose ends	•	•
1.2m fluid connection hose	•	•
Rechargeable battery pack	•	•
12Vdc power supply	•	•
Fast blow fuse	•	•
Unique optical scanning system	•	•
Bonded glass optical window enclosed in SS plate	•	•
Micron channels analysis (Six)	•	•
Analysis range ISO 7 to 22 incl. (NAS 0 to 12)	•	•
32 character dot matrix LCD. Alpha numeric keypad	•	•
Data retrieval	•	•
Calibration to ISO standards*	•	•
Viscosity range 2 to 100 cSt. 500 cSt.with SPS	•	•
Operating temp.+5 to +80°C	•	•
Ambient temp.+5 to +40°C	•	•
2 minute test completion time	•	•
Memory store – 300 test memory	•	•
Battery operated 6 x 1.5 D cells	•	•
Phosphate Ester group compatibility	•	•
Mineral oil & petroleum based fluid compatibility	•	•
Up to 420 bar (6000 psi)	•	•
Integral 16 column printer	•	•
RS232 computer interface	•	•
Astra board case weight – (Kg)	5	5
Unit weight – (Kg)	8	8
DATUM software and cable link pack	•	•
Weather protector cover	•	•
CE certified	•	•
Auto logging	•	•

\*Note: In compliance with international standards, all Parker portable particle counters can meet the ISO Medium test dust standards. The LaserCM's, in addition to the complete range of Condition Monitoring products, are capable of achieving certification to ISO 4406:1999 and with traceability to ISO 11171 for SRM 2806, via ISO 11943.

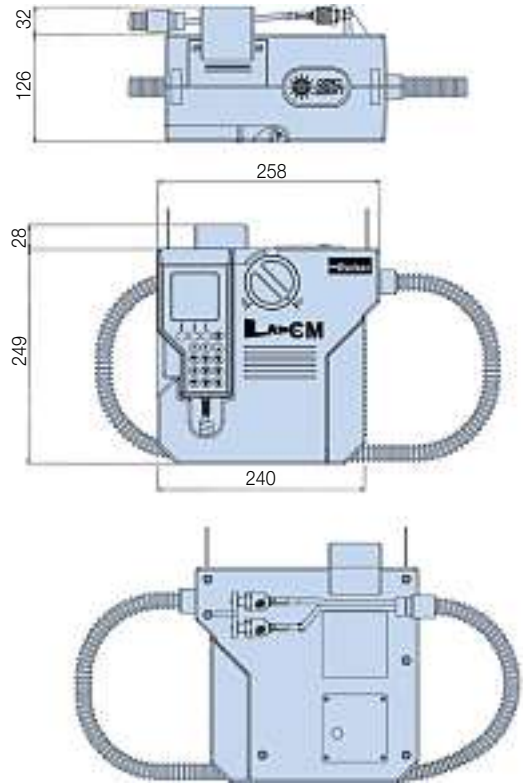

### Commissioning Kit

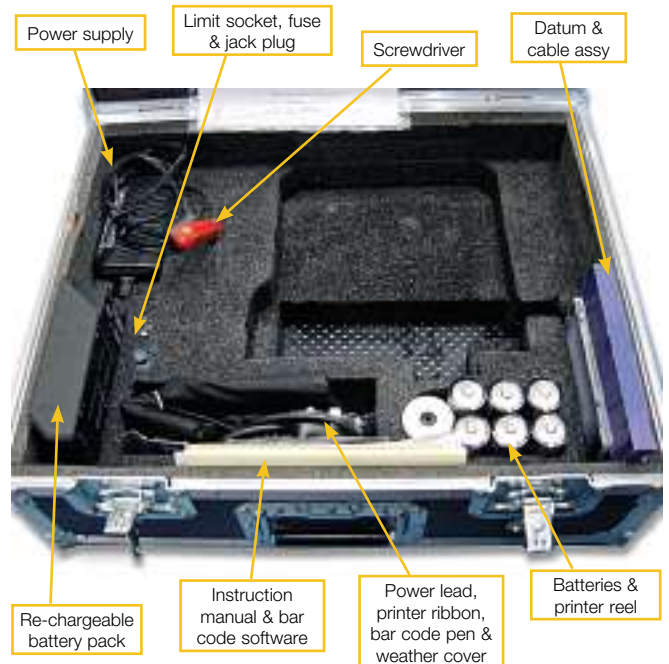



## Operation

Switch On



Operating the Parker LaserCM is as simple as pressing the start button and turning the dial. The test procedure is automatic and in the case of the LaserCM takes no more than 2 minutes to complete.

### LaserCM makes the difference in industry

Fully accredited to BS EN 60825:1992 and IEC 60825-1 (safety of laser products) Standards, accredited to USA Standards and achieving full ISO certification. LaserCM offers users advanced laser technology, a fast, dynamic and on-line 2 minute system test cycle. A LaserCM Aggressive Fluids model is also available, suitable for monitoring corrosive fluids such as phosphate ester based lubricants used in commercial aviation.

### MTD calibration

Laser CM20 MTD Calibration variants are certified via a primary ISO 11171 calibrated automatic particle counter. All MTD Laser CM20's achieve ISO 4406:1999 criteria, via ISO 11943.

### LCM20 Using SPS



Start Test



### Understanding MTD

ACFTD (Air Cleaner Fine Test Dust) was formatted in the 1960's, but is no longer being produced. The obsolescence of this dust has led to the adoption of a new dust MTD.

MTD (Medium Test Dust) having a particle size distribution close to ACFTD was selected as a replacement. However, MTD produced results somewhat different to ACFTD, so the NIST (National Institute of Standards & Technology) undertook a project to certify the particle size distribution of ISO MTD.

The result was particle sizes below 10µm were greater than previously measured.

Particle sizes reported based on NIST would be represented as µm (c), with "c" referring to "certified". Therefore the CM20 reported sizes are as follows:

#### ACFTD MTD

2µ	4µ (c)
5µ	6µ (c)
15µ	14µ (c)
25µ	21µ (c)
50µ	38µ (c)
100µ	70µ (c)

MTD offers true traceability, improved particle size accuracy and better batch to batch reproduction.

# LaserCM

## Why On-Site Fluid Contamination Monitoring?

- Certification of fluid cleanliness levels.
- Early warning instrument to help prevent catastrophic failure in critical systems.
- Immediate results with laboratory accuracy.
- To comply with customer cleanliness requirements and specifications.
- New equipment warranty compliance.
- New oil cleanliness testing.



## Datum Data Management



Datum, dedicated software, provides the link between a Laser CM20, System 20 EM20 or the H<sub>2</sub>Oil - Water in Oil and your computer management system.

### Features:

- Windows based, Icon driven program
- Full graphic output
- Tables/results download
- Trend analysis and predictive maintenance
- Auto test communication allows Datum to control particle counter testing and water in oil monitoring
- Certification creator using downloaded data
- Customer customised fields



16-column printer for hard copy data. A feature of the LaserCM is the on-board printout data graphing option developed to support predictive maintenance procedures.

Laser CM Test		Laser CM Test	
ON LINE TEST		ON LINE TEST	
TEST NUMBER 022		TEST NUMBER 022	
		D M Y	
Date	04-03-06	Date	04-03-06
Time	15-52	Time	15-52
ISO:	20/15/09	NAS CLASS:	7
		Count / 100ml	
>4µ (c)	820721	4/6µ (c)	789157
>6µ (c)	31564	6/14µ (c)	31250
>14µ (c)	314	NAS CLASS	7
>21µ (c)	64	14/21µ (c)	250
>38µ (c)	14	NAS CLASS	3
>70µ (c)	0	21/38µ (c)	50
NOTES		NAS CLASS	3
		38/70µ (c)	14
		NAS CLASS	4
		>70µ (c)	0
		NAS CLASS	0
		NOTES	

ISO 4406 - 1999

Correlation to NAS 1638

## Introducing the new LCM 'Classic'

There is a new addition to the proven range – the LCM 'Classic'. Only available from Parker, the 'Classic' retains all the technology that made the LaserCM one of the most accurate, reliable and popular portable particle counters available.

Our design engineers have re-configured the LaserCM specification in a way that has reduced our manufacturing costs. These savings have been passed onto LCM 'Classic' customers.

### How have we done this?

First we talked to our existing customers and then to the engineers and maintenance operatives to find out the features that make the LaserCM a unique predictive maintenance instrument.

Then, we removed peripheral items such as the aluminium case and all the accessories, so a customer receives the monitor, with a CD user guide, professionally and securely boxed. One thing that has not altered is laser accuracy and laser reliability. Our in-house software engineers have re-configured the EPROM, removing Data programming, User ID, Automatic Testing, Data retrieval, Alarm level settings, the barcode pen and Graph printing functions to reduce costs still further without in any way reducing the efficiency of the monitor. The LCM 'Classic' is an instrument to be proud of.



## Ordering Information (LaserCM and 'Classic' LaserCM)

### Standard products table

Part number	Supersedes	Description
<b>LCM202022</b>	N/A	MTD calibrated
<b>LCM202026</b>	N/A	Classic unit - MTD calibrated
<b>B84702</b>	B.84.702	Printer paper (5 rolls)
<b>P843702</b>	N/A	Printer ribbon
B84729	B.84.729	12Vdc power supply
B84609	B.84.609	Re-chargeable battery pack
P849613	N/A	Weather protector cover
<b>B84779</b>	B.84.779	Datum software pack
B84708	B.84.708	Cable and adaptor

Note 1: Part numbers featured with bold highlighted codes will ensure a 'standard' product selection.

Note 2: Alternate displayed part number selection will require you to contact Parker Filtration for availability.

### Product configurator

Model	Fluid type		Options	
<b>LCM2020</b>	<b>2</b>	Hydraulic mineral	<b>1</b>	ACFTD calibrated
		Skydrol	<b>2</b>	MTD calibrated
	3		ACFTD calibrated + bar code pen	
	4		MTD calibrated + bar code pen	
	<b>5</b>		Classic unit - ACFTD calibrated	
	<b>6</b>	Classic unit - MTD calibrated		

Note 1: Part numbers featured with bold highlighted codes will ensure a 'standard' product selection.

Note 2: Alternate displayed part number selection will require you to contact Parker Filtration for availability.



# Universal Bottle Sampler



# Universal Bottle Sampler

## Features & Benefits

- Simple operation
- Efficient testing procedure
- Clean and contamination free sampling
- Available for both mineral based and aggressive fluids
- Further advances the LCM20's flexibility into laboratory bottle sampling environments
- Can accept various different sized bottles
- Minimal working parts
- Internal auto setting fuse for overload protection
- Simple maintenance procedures

## Typical Applications

- Batch sampling
- Aircraft rig certification
- Oil research
- Laboratory testing
- Transfer line monitoring

### Providing The Dynamic Link To All Portable Particle / Water Counters.

The UBS off-line, has microprocessor technology to recognise and adjust to the connecting monitor including the LaserCM and Water in Oil Monitor.

### Simple To Use UBS

The oil sample is drawn into the UBS Off-line where it is secured, free from further contamination, in a bottle together with a clean waste bottle by a peristaltic, self-priming pump. Simple operation and efficient testing are assured once the UBS Off-line is connected to any of the CM monitors, and powered up using it's own power source. The oil sample requires agitation and de-gassing before carrying out the contamination test. A de-gassing kit option is available and consists of a vacuum chamber and pump. (Standard with UBS.9002)



## Specification

Description	UBS offline
Viscosity range 2 to 250 cSt	●
Operating temp +5 to +80°C	●
Test time 2m15s / 4m15s (Flush 2m)	●
12 Vdc power supply	●
Extruded aluminium construction	●
Unit weight - (Kg)	4
Mineral oil and petroleum based compatibility	Fluorocarbon seal
Phosphate Ester group compatibility	EPDM seals
CE certified	●
Military approved	●
Manual operation	●
Bottle pack	●
De-gassing chamber	●
Manual	●
Sample tube pack	●
Interface cable to LCM20, H <sub>2</sub> Oil etc.	●

## Installation Details

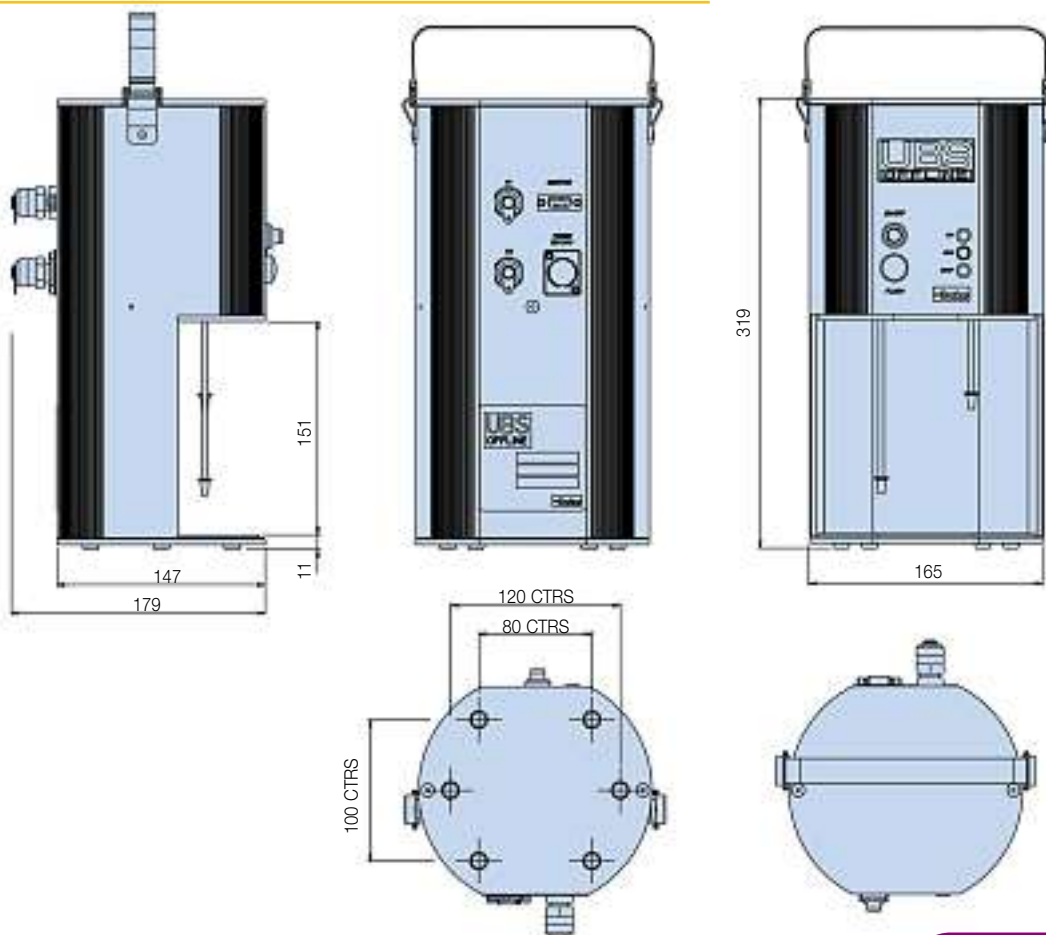

# Universal Bottle Sampler

## Usage Specifications

### System Flow Rate

Samples are best taken from a point in the system where the flow is TURBULENT (Reynolds No. greater than 4000). The turbulent flow creates a mixing action. Where flow is streamline or LAMINAR, larger particulate may tend to settle toward the lower pipe surface and not be sampled.

### System Condition Changes

Changes in the system operating condition, flow, temperature, pressure or vibration, can result in previously sedimented contaminant being retrained into the flowing oil. It is also possible that these changes may cause partially contaminated filter elements to shed particulate into the system. Samples should, therefore, be extracted when the system is in a steady state condition and the result less likely to be distorted by contaminant peaks.

There are a number of proprietary sampling valves available which adhere to good theoretical principles. However, they do tend to generate a level of precision and cost which is unnecessary for trend monitoring.



Sampling points should enable extraction of a sample without changing the system's condition. Fine control needle valves are not desirable, as they have a tendency to silt up under some operating conditions, causing the distribution of contaminants in the fluid to be changed. The sampling port should be protected to maintain cleanliness and thoroughly flushed before collecting the sample for analysis. Allow sufficient airspace in the bottle to enable 80% fill.

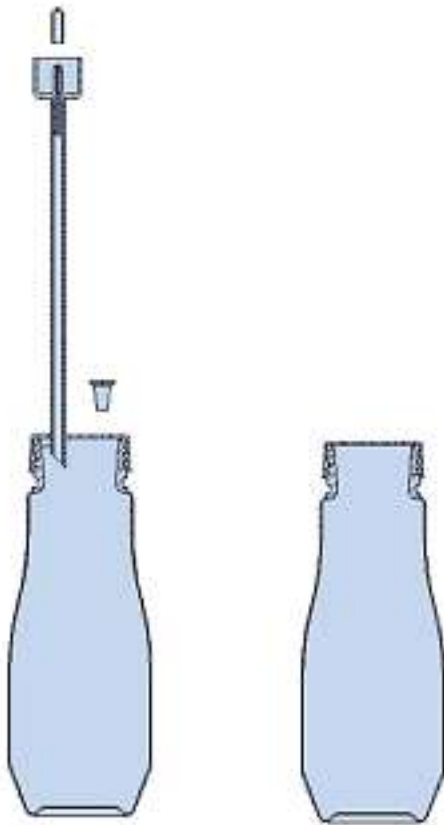

B.89.911 x 50 = B.89.910

B.89.907

### Bottle Cleanliness

It is preferable that bottles have sealing screw caps and both parts are cleaned to a suitable level in accordance with ISO3722.

The bottle should not contain more than one tenth the number of particles per 100ml than are expected to be monitored. Standard Parker bottles are supplied clean to ISO13/11 (NAS Class 4) and should not be used to accurately count oils cleaner than ISO 15/12 (NAS Class 6) although they may be used for "trend monitoring" at lower levels.

The bottle should remain capped until time of sample filling and re-capped immediately afterwards.

### Sample Mixing

Sedimentation of contaminant in a sample will occur, the rate of which is dependent upon both fluid and particle characteristics.

Samples should be analysed, without delay, once agitated and de-gassed.



## Ordering Information

### Standard products table

Part number	Description
<b>UBS9002</b>	Universal bottle sampler (includes aluminium case and accessories)
<b>UBS9003</b>	Universal bottle sampler
<b>UBS9004</b>	Aggressive universal bottle sampler
<b>UBS9005</b>	Aggressive universal bottle sampler (Includes aluminium case and accessories)

### Accessories

Part number	Supersedes	Description
<b>B89907</b>	B.89.907	Sample bottle pair with plain cap
<b>B89911</b>	B.89.910	Sample bottle pair with oil extraction hose
<b>B89910</b>	B.89.910	Sample bottle pack (50 x B89911)
S840054	N/A	Power supply and socket
S890005	N/A	De-gassing chamber and pump
B89603	B.89.603	De-gassing chamber only
B89902	B.89.902	Cable and adaptor

Note 1: Part numbers featured with bold highlighted codes will ensure a 'standard' product selection.

Note 2: Alternate displayed part number selection will require you to contact Parker Filtration for availability.





# Single Point Sampler



# Single Point Sampler

## Features & Benefits

The Single Point Sampler provides a means to connect an LCM20 or H<sub>2</sub>Oil to a single pressure test point and balance the differential pressure across the system, to provide a controlled flow of oil into the monitor and away into a waste oil receptacle.

- Lightweight, compact and easy to use design
- Fingertip operated control valve even at high pressures
- 420 bar (6,000PSI) rated
- Facilitates testing from large diameter pipes
- Capability to test up to 500cSt viscosity oils (pressure permitting)
- Pressure compensated flow control mechanism
- Possible to control the valve with the same level of accuracy whether the device is operating at high or low pressure
- Capable of allowing a flow rate in excess of 10ml/min when operating at any viscosity within the product specification
- Suitable for fluid temperatures from +5°C to +80°C (+41°F to +176°F)
- High quality polished finish. (stainless steel/ aircraft grade aluminium)
- Capable of working with a LCM20 or H<sub>2</sub>Oil connected into a system via the standard one metre extension hose kit
- Suitable for use with mineral and biodegradable oils, petroleum based and phosphate ester fluids
- Phosphate ester version utilises the <sup>5</sup>/<sub>8</sub>" BSF HSP style fitting
- Designed so that it meets the lowest possible level of magnetic permeability
- Supplied with accessories kit
- It will maintain the set flow rate between upper and lower limits within a 100 bar inline pressure change
- Clear product identification to ensure that it is connected correctly. (i.e. downstream of the LCM20 or H<sub>2</sub>Oil)



## Connection Instructions

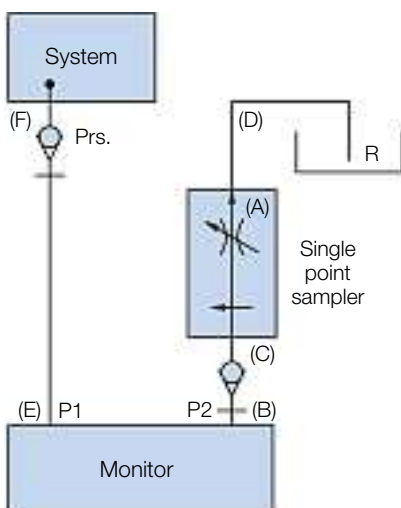

1. Ensure valve is closed (A).
2. Connect P2 on monitor (B) to P2 on Single Point Sampler (SPS) (C).
3. Connect drain line on SPS (D).
4. Connect P1 of monitor (E) to the system (F).
5. The SPS is ready to operate.
6. Open valve (A) slowly until the oil flows continuously from the drainline (D).
7. Switch on monitor and begin testing.

### LCM20 Only

Carry out flow test as shown in the manual. If test is showing below  $\Delta t$  3.6°C then carry out test as normal. If, however, test is above  $\Delta t$  3.6°C then increase oil flow by turning valve (A) anticlockwise and then carry out flow test. Do this until  $\Delta t$  is below 3.6°C and carry out test as normal once this is achieved.

**WARNING! Ensure that SPS valve is closed and monitor is connected to the SPS BEFORE connection to system.**

## Specification

### Fluid compatibility:

Mineral oil and petroleum based fluids (standard version).  
Aggressive fluid (dual seal version) for other fluids consult Parker Hannifin.

### Seals:

Fluorocarbon or Perfluoroelastomer.

### Maximum working pressure:

420 bar (6000 psi).

### Weight:

500 grams max. (Not including hoses).

### Packaging standard:

Cardboard carton (military usage - plastic carry case).

### Unit size:

45mm dia x 123mm long.

### System connection:

Standard - minimes M16 (G<sup>1</sup>/<sub>4</sub>" BSP) with cap,  
Aggressive - <sup>5</sup>/<sub>8</sub>" BSF HSP.

### Operating temp range:

+5°C to +80°C (+41°F to +176°F).

### Storage temperature range:

-26°C to +80°C (-15°F to +176°F).

### Construction:

Body: Aluminium BS 1470 – pressurised end stainless steel.

Finish: Anodised blue (standard version).

Anodised red (dual seal version).

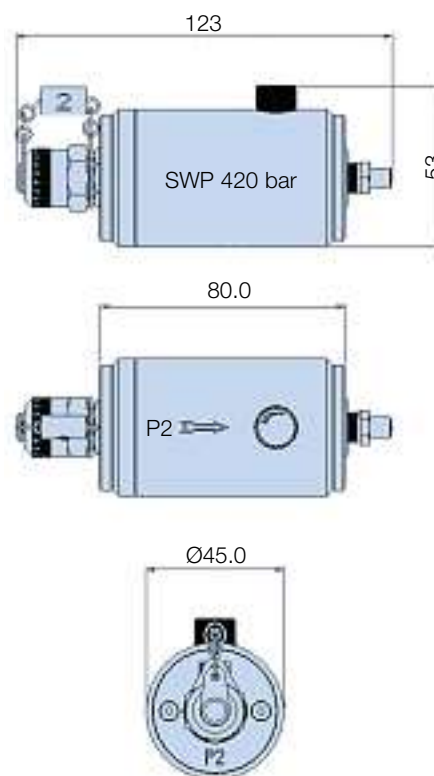

## Ordering Information

### Standard products table

Product number	Supersedes	Description
<b>SPS2021</b>	N/A	Mineral single point sampler
SPS2061	N/A	Aggressive single point sampler
B84784	B.84.784	Mineral or aggressive bottle assembly
B84224	B.84.224	Mineral oil extension hose/coupling
B84225	B.84.225	Aggressive oil extension hose/coupling
B84788	B.84.788	Mineral oil waste hose
B84787	B.84.787	Aggressive oil waste hose

Note 1: Part numbers featured with bold highlighted codes will ensure a 'standard' product selection.

Note 2: Alternate displayed part number selection will require you to contact Parker Filtration for availability.



# System 20



# System 20

## Features & Benefits

Covering a wide range of flow rates, fluid types and applications, Parker's System 20 sensors are designed to be used with System 20 electronic or analogue monitors, contamination monitors and the H<sub>2</sub>Oil. Specially developed System 20 sensors are available for use with aggressive fluids. (EPDM Seals)

- System 20 monitors, combined with the inline sensor, give the user accurate and instant readings of flow, pressure and temperature without the need to shut down the system.
- For use with all mineral oils, water and water/oil emulsions.

### Analogue Monitor

- Utilises 3 Day-Glo dial gauges with a protective hinged cover.
- Calibrated up to 380 l/min with dual scale bar/psi & °C/°F. (US GPM also available)

### EM20 Electronic Monitor

- Gives a full digital display.
- Automatically calibrated for all 3 sizes of sensor.
- Indicates line, differential and rising peak pressure.
- Easily scrolled from metric to US.
- 300 test memory.
- Capable of downloading saved data to datum.



## Typical Applications

- Drilling equipment
- Mining
- Grinding and conveying
- Industrial hydraulics
- Mobile

Hydraulic system users need to ensure that lost production is kept to the absolute minimum. To ensure this, predictive maintenance and therefore routine condition monitoring of major components is essential.

System 20 inline sensors remain at the heart of condition and contamination monitoring. Whether you're mining the coal, building the new bypass, harvesting the crops, crossing the oceans or drilling offshore – whatever the industry, System 20 represents the premier system monitoring available today.





## Specification: Sensors

### Construction:

Machined steel body. Electroless nickel coating to minimum depth of 40 microns  
Brass/stainless steel internal components

### Flow capacities:

All suitable for use with oil, water and water/oil emulsion

Size 0 – 6-25 l/min (0.5-7US GPM)

Size 1 – 20-100 l/min (1.5-26 US GPM)

Size 2 – 80-380 l/min (5-100 US GPM)

### Max. working pressure:

420 bar (6000psi)

### Capability:

Reverse flow

### Pressure drop:

At max. rated flow,  $\Delta p$  is 1.1 bar (mineral oil fluid at 30 cSt 140 SSU).

### Ports:

Size 0 – G<sup>3/8</sup>

Size 1 – G<sup>3/4</sup>

Size 2 – G1<sup>1/4</sup>

} (SAE threads also available)

### Repeatability:

±1% FSD

### Accuracy:

Flow ±2.5% full scale deflection

### Weight:

Size 0 – 0.5kg (1.2lbs)

Size 1 – 3.5kg (8.4lbs)

Size 2 – 4.4kg (9lbs)

### Aggressive Fluid Applications:

EPDM internal/external 'O'-rings and seals

## Installation Details

### Size 0 Sensor

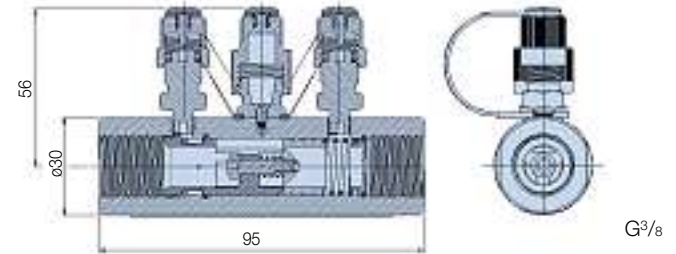

### Size 1 Sensor

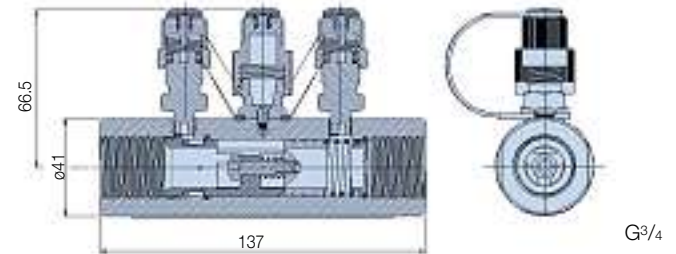

### Size 2 Sensor

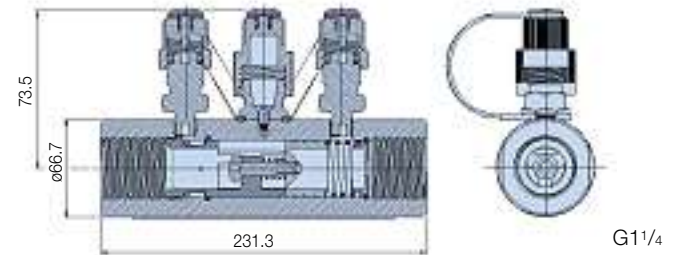

## Ordering Information

### Standard products table

Product number	Supersedes	Size	Flow range l/min	Fluid type	Port threads
<b>STI0144100</b>	STI.0144.100	0	6-25	Mineral	G <sup>3/8</sup>
<b>STI1144100</b>	STI.1144.100	1	20-100	Mineral	G <sup>3/4</sup>
<b>STI2144100</b>	STI.2144.100	2	80-380	Mineral	G1 <sup>1/4</sup>
STI0148100	STI.0148.100	0	6-25	Aggressive	G <sup>3/8</sup>
STI1148100	STI.1148.100	1	20-100	Aggressive	G <sup>3/4</sup>
STI2148100	STI.2148.100	2	80-380	Aggressive	G1 <sup>1/4</sup>

Note 1: Part numbers featured with bold highlighted codes will ensure a 'standard' product selection.

Note 2: Alternate displayed part number selection will require you to contact Parker Filtration for availability.

Note 3: Mobile Sensors are also available - Contact Parker

# System 20

A drilling equipment operation in a zinc mine has had System 20 installed for several years.

## System 20 Saving £50,000 Pump Damage

Installing System 20 was part of a major restructuring plan to improve mining effectiveness and profitability. Machine operator training and oil storage operative training were essential elements of the plan. Prior to this investment, pump terminal damage could cost £10,000 for a replacement, over £1000 service costs and up to £39,000 in lost production. Add to this the difficulties of the mine's geography and it's easy to see the problems that have now been overcome.

## System 20 Electronic Monitor

With System 20 inline sensors installed in a hydraulic system, faults can be predicted and remedied, all you have to do is connect the System 20 Electronic Hand Held Monitor (EM20). Designed to display flow, temperature, differential, rising peak and line pressure, System 20 Electronic can also calculate hydraulic power (kW and hp.) at a given point in a system to establish efficiency and power consumption.

System 20 electronics versatility does not end there. The EM20 is automatically calibrated for all System 20 inline sensors using water or oil and can display in l/min, US GPM, bar, psi and kg/cm<sup>2</sup>.



Battery powered and completely portable, the EM20 displays readings on the LCD and can store under a test number. Data can be downloaded via an RS232 connection to Datum. A sealed keyboard and fingertip control make the unit maintenance free and simple to use anywhere.

## System 20 -The Key To Predictive Maintenance

The risk of fluid contamination by intrusive test devices is eliminated. Using System 20 Sensors and the monitor together, hydraulic fluids need never be disturbed. The monitoring procedure takes only a matter of minutes. With one System 20 monitor a user can check a complete fleet of vehicles or a factory full of hydraulic plant equipment. Predicting a problem means it can be put right as part of a planned maintenance programme. Simple routine monitoring with System 20 keeps machines running at a high level of operational efficiency.

## System 20 Saving £325,000 A Day Lost Production

The mining industry puts a considerable demand on hydraulics and there are others such as agricultural machinery, harvesters or tractors and, for example, cement manufacturing plants that are equally demanding of hydraulic efficiency.

A grinding and conveying plant processes in excess of 1000 tons of ore per day in the manufacture of cement products. A days lost production costs £32,000. After one year of operation the Plant Engineers decided to invest in System 20 equipment, strategically placed to allow the Engineers to 'fault-find' the major components quickly and easily. The result is that downtime and loss of production have been reduced by 80%.



## System 20 -The Proven System

For operators of industrial and mobile machinery who recognise the benefits of installing System 20 in a hydraulic system, the System 20 hand-held analogue monitor offers significant advantages, particularly in intrinsically safe applications. Like the System 20 electronic, the analogue monitor is completely portable and can be connected immediately to a purpose-designed inline System 20 sensor but requires no power source.

The analogue monitor will then - provide the user with an accurate and repeatable analysis of system flow, pressure and temperature - without having to stop the machine.

Designed as a sealed assembly requiring no routine maintenance or adjustment, analogue monitors are suitable for use with all mineral oils, water/oil emulsions and water.



The lightweight monitor has 3 dayglo dial gauges and features a protective hinged cover. The flow scale features double scale calibration - up to 100 l/min and 380 l/min and has excess flow and reverse flow indication.

## Electronic Monitor Specification

### Construction:

A sealed assembly requiring no routine maintenance or adjustment. Body moulding in Acrylonitrile Butadene Styrene (ABS). Key pad moulded in silicon rubber. The monitor is suitable for use with all mineral oils, water and water/oil emulsions.

### LCD details

#### Flow section:

The analogue flow scale has reverse flow and overflow indication and provides a percentage reading of the digital full scale display automatically calibrated for all sizes of System 20 Sensor.

#### Pressure section:

Designed to indicate line pressure, differential pressure and rising peak pressure. Connected to a System 20 Sensor it will monitor pressure up to 420 bar (6000 psi) with an accuracy of  $\pm 1\%$  FSD.

#### Temperature section:

Temperature reading between  $-10^{\circ}\text{C}$  and  $+110^{\circ}\text{C}$  ( $0^{\circ}\text{F}$  to  $230^{\circ}\text{F}$ ).

### Dimensions:

The ABS Case is 291mm (11.46") long, 105mm (4.13") wide and 76mm (3") deep overall.

### Weight:

1.4kg (3lbs).

### Data logging:

Each test logs the following data:

Test number; time & date; sensor size; media tested; flow rate, pressure & temperature.

### Data download:

The System 20 electronic monitor is capable of downloading saved test data to a 16 column serial printer, or a compatible PC via an RS232 connection using datum.

### Batteries:

6 x AA batteries.

### Re-calibration:

Annual certification by an approved Parker Service Centre.

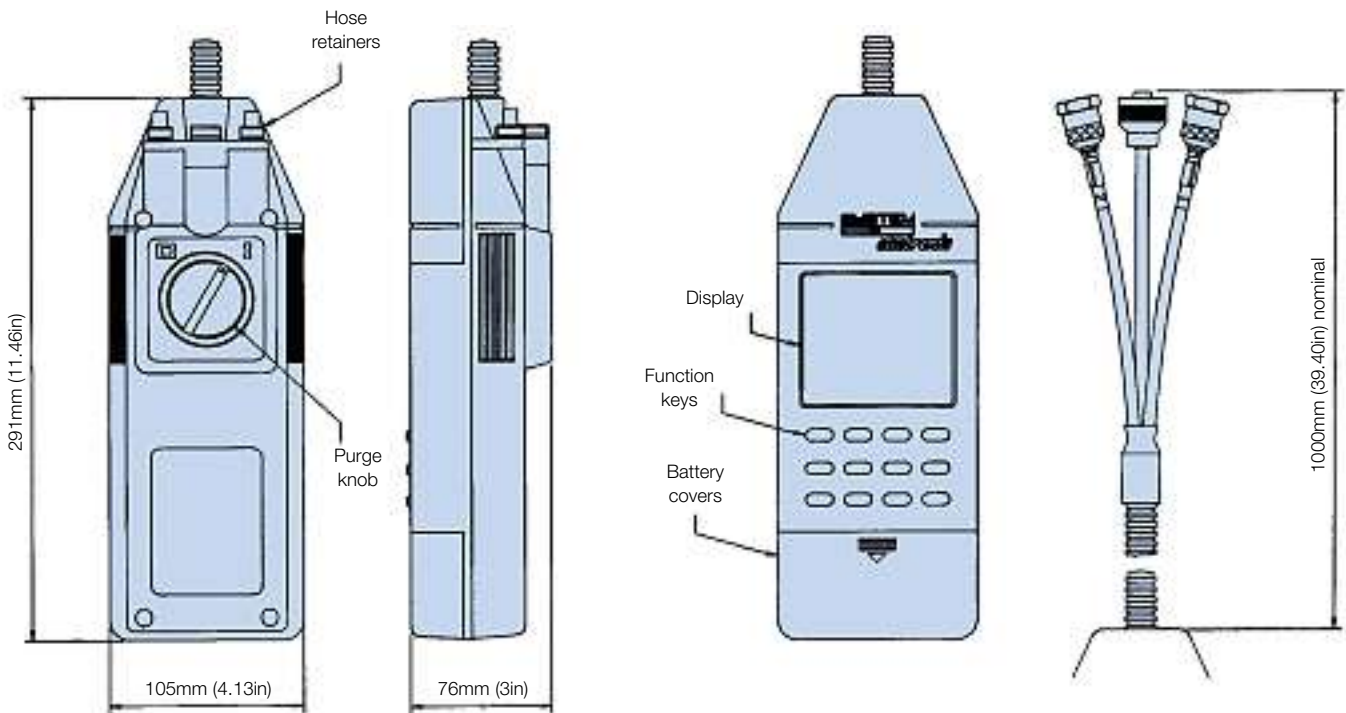

## Ordering Information

### Standard products table

Product number	Supersedes	Description
<b>EM209000</b>	N/A	System 20 electronic monitor
<b>B84779</b>	B.84.779	Datum download software
P653607	N/A	Monitor and sensor carrying case
B85617	B.85.617	Dongle and cable assembly

Note 1: Part numbers featured with bold highlighted codes will ensure a 'standard' product selection.

Note 2: Alternate displayed part number selection will require you to contact Parker Filtration for availability.

# System 20

## Analogue Monitor Specification

**Construction:**

A sealed assembly requiring no routine maintenance or adjustment. Body moulding in Acrylonitrile Butadene Styrene (ABS). The monitor is suitable for use with all mineral oils, water and water/oil emulsions. The monitor has 3 dayglo dial gauges and features a protective hinged cover.

**Gauge details**

**Flow section:**

The flow scale has double scales for size 1 and 2 sensors only. Calibrated up to 100 l/min (26 US GPM) and 380 l/min (100 US GPM). The flow dial has excess-flow indication.

When the system is in reverse flow or when the high pressure lines to the sensor have been transposed, a 'below zero' indication is given.

**Pressure section:**

Dial readings in both bar and psi up to 420 bar (6000psi).

**Temperature section:**

The temperature dial gives readings between -10°C and +110°C (0°F to 230°F).

**Dimensions:**

The ABS Case is 292mm (11.5in) long, 108mm (4.25in) wide and 67mm (2.64in) deep overall.

**Weight:**

1.4kg (3lbs).

A viscosity chart is provided for mineral oil applications where monitoring is required at variable viscosities (cSt).

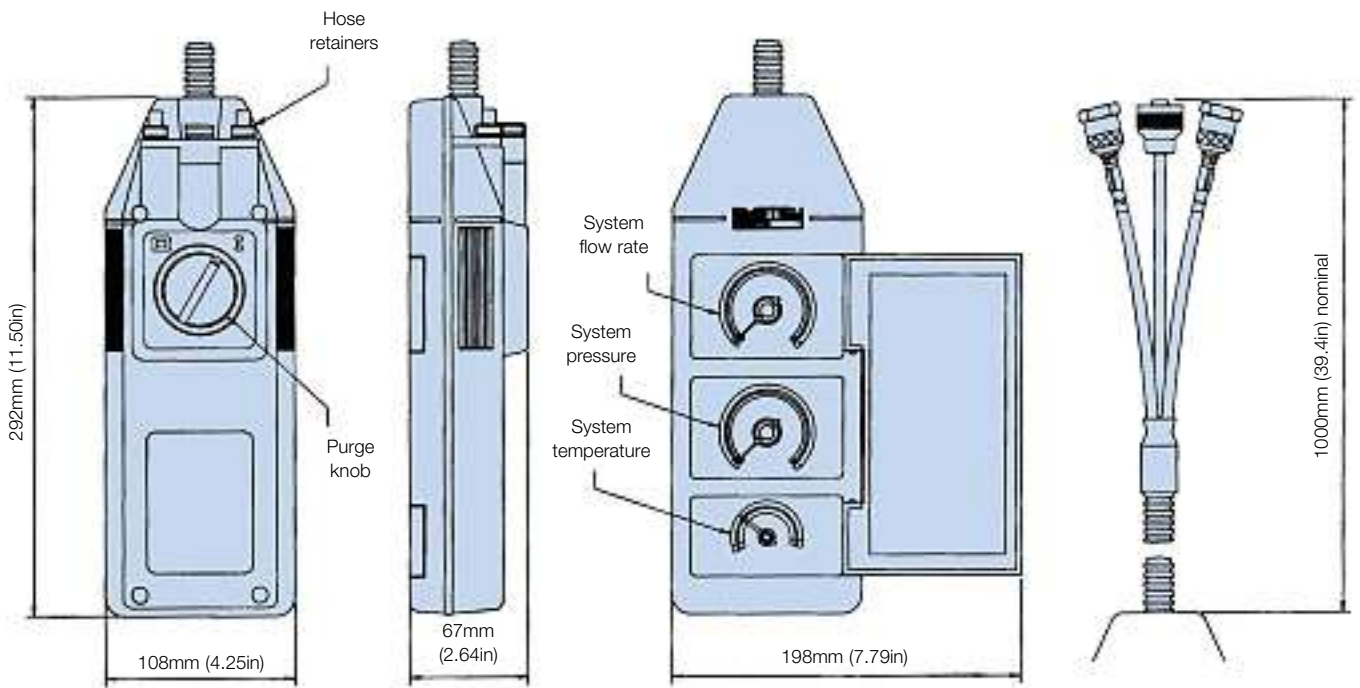

## Ordering Information

**Standard products table**

Product number	Supersedes	Media type	Flow readings	Pressure readings	Temperature readings
<b>STM6211110</b>	STM.6211.110	Oil	l/min	Dual scale bar/PSI	Dual scale °C/°F
STM6611110	STM.6611.110	Oil	US GPM	Dual scale bar/PSI	Dual scale °C/°F
STM6211120	STM.6211.120	Water	l/min	Dual scale bar/PSI	Dual scale °C/°F
STM6611120	STM.6611.120	Water	US GPM	Dual scale bar/PSI	Dual scale °C/°F

Note 1: Part numbers featured with bold highlighted codes will ensure a 'standard' product selection.

Note 2: Alternate displayed part number selection will require you to contact Parker Filtration for availability.

**Accessories**

Product number	Description
P653607	Monitor and sensor carrying case
P653106	Metal sensor protective cap

# MCM20



# MCM20

## Features & Benefits

- The MCM20 is an online continuous particle counter ensuring constant system monitoring within defined parameters.
- PC/PLC controlled
- Ensures constant system monitoring.
- Can be pre-set to carry out tests at specific intervals.
- Can also be set up via detachable Handset.
- Enclosed in a metal casing, with internal workings on a removable chassis for ease of service and calibration.
- Connects permanently to a System 20 sensor via 2 meter hose assembly (supplied).
- Simple data formatting programme for trend analysis.
- User-friendly instrument improving familiarity and awareness of service and maintenance personnel.

## Typical Applications

- Test rigs
- Construction machinery
- Industrial plant
- Hydraulic equipment & system manufacturers
- Paper processing
- Steel rolling mills
- Military equipment application

### The Parker MCM20

Using proven portable particle counting technology (LCM20), the MCM20 and its principles are available to users where continuous, permanent installed monitoring is required.

The MCM20 utilises the latest laser diode method of particle counting. The unit is enclosed in a metal casing with access to the hydraulic connection, DC input power, fuse holder and PC/PLC connection ports located on the front panel.

The internal workings are manufactured onto a removable chassis for ease of service and calibration.



## Specification

### Test cycle time:

Variable between 30 seconds and 3 minutes.

### Repeat test time:

Continuous Mode or between 30 seconds and 1440 minutes (24 Hours).

### Principle of operation:

Optical scanning analysis and measurement of actual particles.

### Particle counts:

6 channels either ACFTD or MTD calibrated.

### International codes:

ISO 7-22, NAS 0-12.

### Storage temperature:

-40°C to +80°C.

### Operating temperature:

+5°C to +60°C (hydraulic oil temperature).

### Unit control connection:

Terminal protocol via RS 232 or optional handset.

### Data retrieval:

Local PC / PLC program or by optional handset.

### Calibration:

By accepted on-line methods confirmed by relevant International Standard Organisation procedures.

### Re-calibration:

Annual certification by an approved Parker Service Centre.

### Max. working pressure:

420 bar.

### Minimum working pressure:

2 bar.

### Fluid compatibility:

Mineral oil or petroleum based fluids.  
Aggressive fluid version also available.

### Sample requirements:

0.3 – 1.5 DP bar (differential pressure) via approved inline sampling concept.

### System connection:

Via System 20 inline sensors / single point sampler

### Computer compatibility:

Interface via RS 232 connection @ 9600 baud rate.

### Size/weight:

249mm x 254mm x 191mm / 8.75kg.

### Power requirement:

12 Vdc input. (1.25A (T) fuse). Regulated.

### Installation:

Back/base M6x1.0 mounting inserts (see annotated diagrams).

### Software:

LabView demonstration software.

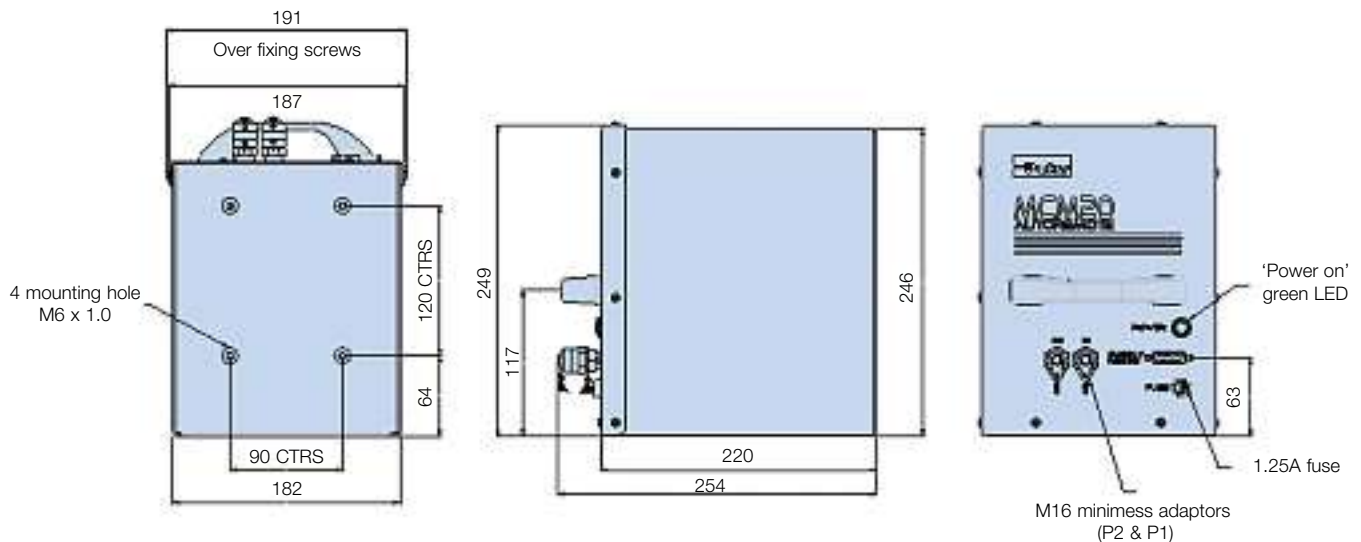

# MCM20

## Communications Protocol

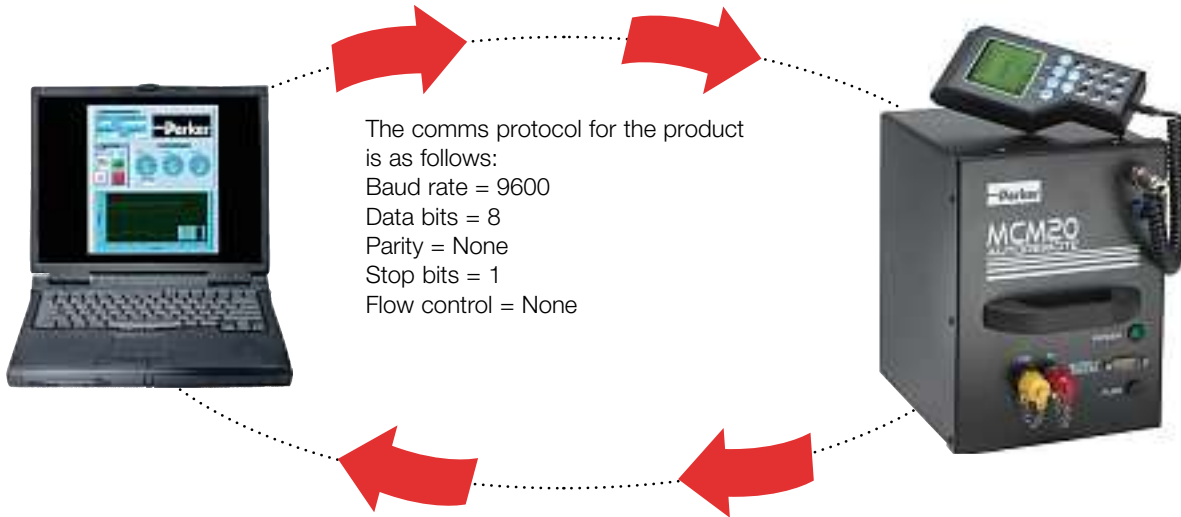

## Labview

## Optional Remote Handset



- Customised demonstration/software for MCM operation.
- Full graphic display.
- Visual indication of limit parameters.



Optional remote handset for direct interface control. Please consult Parker for more information.

### Standard products table

Product number	Supersedes	Description
<b>MCM202022</b>	N/A	MTD calibrated - mineral
<b>MCM202022HS</b>	MCM20.2022.HS	MTD calibrated - mineral - with handset
<b>MCM202021</b>	N/A	ACFTD calibrated - mineral
<b>MCM202021HS</b>	MCM20.2021.HS	ACFTD calibrated - mineral - with handset
<b>MCM202061</b>	N/A	ACFTD calibrated - aggressive
<b>MCM202062</b>	N/A	MTD calibrated - aggressive
<b>MCM202061HS</b>	MCM20.2061.HS	ACFTD calibrated - aggressive - with handset
<b>MCM202062HS</b>	MCM20.2062.HS	MTD calibrated - aggressive - with handset
<b>B94106</b>	B.94.106	Handset (blue)
<b>B94107</b>	B.94.107	Handset (red)
<b>B94802</b>	B.94.802	2m mineral hose assembly
<b>B94801</b>	B.94.801	2m aggressive hose assembly

Note 1: Part numbers featured with bold highlighted codes will ensure a 'standard' product selection.

Note 2: Alternate displayed part number selection will require you to contact Parker Filtration for availability.



# Icount<sub>PD</sub>



# Icount<sub>PD</sub>

## Features & Benefits

**Diagnostic Self Check Start-up Time:**

5 seconds

**Measurement Period:**

5 to 180 seconds

**Reporting interval through RS232:**

0 to 3600 seconds

**Digital LED display update time:**

Every second

**Limit Relay Output:**

Changes occur +/- 1 ISO code at set limit (Hysteresis ON) or customer set (Hysteresis OFF)

**4-20mA Output Signal:**

Continuous

**Principle of operation:**

Laser diode optical detection of actual particulates.

**Reporting Codes:**

ISO 7 – 21, NAS 0 – 12, (AS 00 – 12 Contact Parker)

Icount will also report less than ISO 7, subject to the statistical uncertainty defined in ISO4406:1999, which is shown in the RS232, reporting results as appropriate e.g ">6"

**Calibration:**

By recognised on-line methods, confirmed by the relevant International Standard Organisation procedures.

**Calibration Recommendation:**

12 months

**Performance:**

+/- 1 ISO Code (Dependant on stability of flow)

**Reproducibility / Repeatability:**

Better than 1 ISO Code

**Power Requirement:**

Regulated 9 to 40Vdc

**Maximum Current Draw:**

150mA

**Hydraulic Connection:**

M16 x 2 hydraulic test points (5/8" BSF for aggressive version)

**Flow Range through the device:**

40 to 140 ml/min (Optimum Flow = 60ml/min)

**Online Flow Range via System 20 Inline Sensors:**

Size 0 = 6 to 25 l/min - (Optimum Flow = 15 l/min)

Size 1 = 24 to 100 l/min - (Optimum Flow = 70 l/min)

Size 2 = 170 to 380 l/min - (Optimum Flow = 250 l/min)

**Required Differential Pressure across Inline Sensors:**

0.4 bar (Minimum)

**Viscosity Range:**

10 to 500 cSt

**Temperature:**

Operating Environment -20°C to +60°C (-4°F to +140°F)

Storage -40°C to +80°C (-40°F to +176°F)

Operating Fluid 0°C to +85°C (+32°F to +185°F)

**Working pressure:**

2 to 420 bar (30 to 6,000 PSI)

**Moisture sensor calibration:**

±5% RH (over compensated temperature range of +10°C to +80°C)

**Operating humidity range:**

5% RH to 100% RH

**Moisture sensor stability:**

±0.2% RH typical at 50% RH in one year

**Certification:**

IP66 rated

EMC/RFI – EN61000-6-2:2001

EN61000-6-3:2001

**Materials:**

User friendly Abs construction.

Stainless Steel hydraulic block.

Viton seals.

**Dimensions:**

182mm x 155mm x 86mm (7.2" x 6.1" x 3.4")

**Weight:**

1.3kg (2.9lb)

- Independent monitoring of system contamination trends
- Early warning LED or digital display indicators for Low, Medium and High contamination levels.
- Moisture % RH indicator (optional)
- Cost effective solution in prolonging fluid life and reducing machine downtime.
- Visual indicators with power and alarm output warnings.
- Continuous performance for prolonged analysis
- Hydraulic, Phosphate Ester & Fuel fluid compatible construction
- Self diagnostic software
- Fully PC/PLC integration technology such as:
  - RS232 and 0-5 Volt, 4-20mA, CAN (J1939) (Contact Parker for other options).

## Icount<sub>PD</sub>

The Icount Particle Detector from Parker represents the most up to date technology in solid particle detection.

The design dynamics, attention to detail and moulding compactness of the permanently mounted, on-line particle detector module, combined with on-board, laser based, leading-edge technology, brings to all industries a truly revolutionary, particle detector as a remarkable cost effective market solution to fluid management and contamination control.



# Icount<sub>PD</sub>

## Dimensions / Installation Details

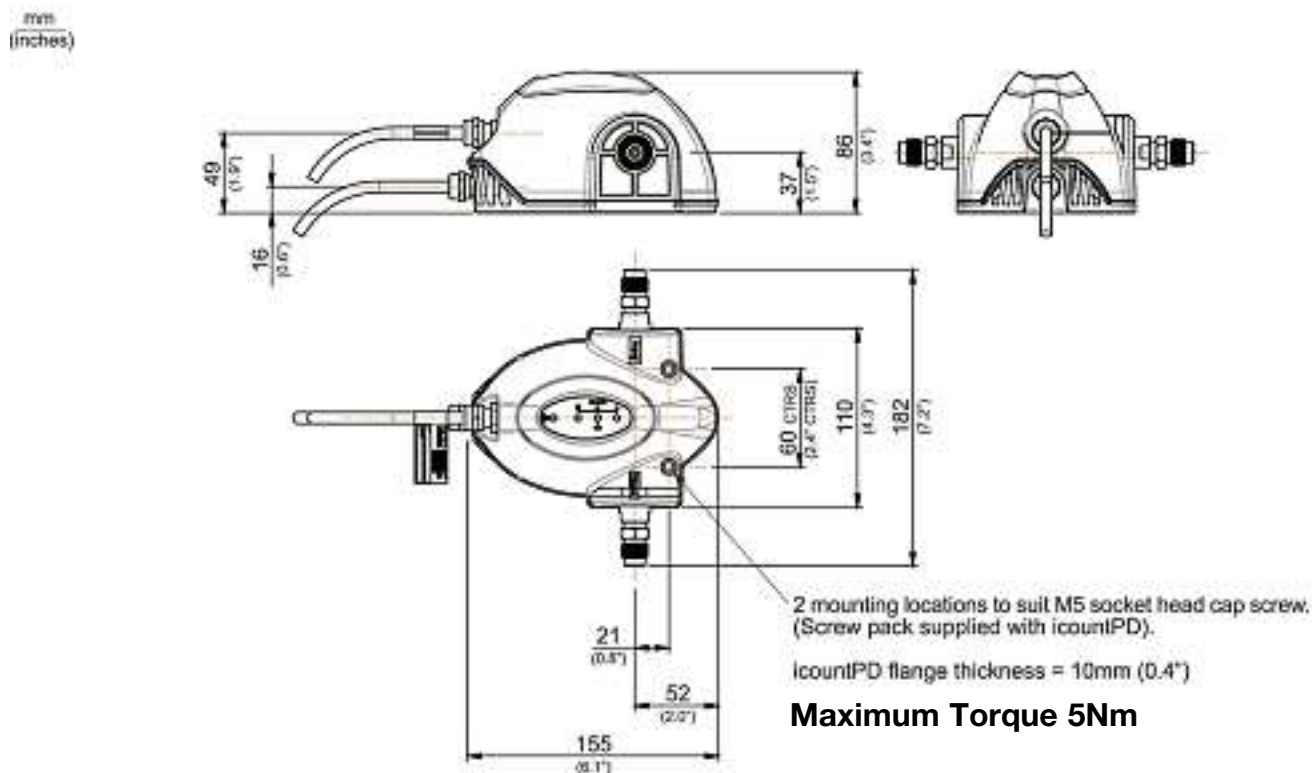

## Typical Applications

- **Mobile Equipment**

- Earth Moving Machinery
- Harvesting
- Forestry
- Agriculture

Monitoring of the hydraulics, enabling the vehicles to function to their best capability under load conditions through pistons, servo valves, control rams and gear pumps.

- **Industrial Equipment**

- Production Plants
- Fluid Transfers
- Pulp & Paper
- Refineries

To monitor the cleanliness of the equipment throughout the production line, from the machine tool controlled hydraulics through to contamination of fluid transfer. Ensuring the integrity of the fluid is maintained throughout the refining process.

- **Power Generation**

- Wind Turbines
- Gearboxes
- Lubrication Systems

With continuous monitoring the optimum level is achieved in the least amount of time.

- **Maintenance**

- Test Rigs
- Flushing Stands

To increase efficiency of your equipment by continuously monitoring the cleanliness level of the hydraulic fluid.

## M12 Communication cable: wiring configuration

M12 Communication cable

Pin	4-20mA option connections	0-5v/0-3v option connections
1	NOT USED	NOT USED
2	RS232 Ground (Pin 5 <sup>**</sup> )	RS232 Ground (Pin 5 <sup>**</sup> )
3	Channel A, ISO 4 $\mu$ m(c)*	Channel A, ISO 4 $\mu$ m(c)*
4	Channel B, ISO 6 $\mu$ m (c)* or NAS (if selected)	Channel B, ISO 6 $\mu$ m (c)* or NAS (if selected)
5	RS232 Receive (Pin 3 <sup>**</sup> )	RX232 Receive (Pin3 <sup>**</sup> )
6	RS232 Transmit (Pin 2 <sup>**</sup> )	RS232 Transmit (Pin 2 <sup>**</sup> )
7	Moisture sensor channel (if fitted)	Moisture sensor channel (if fitted)
8	Channel C, ISO 14 $\mu$ m (c)*	Channel C, ISO 14 $\mu$ m (c)*

Important Note: It is the responsibility of the end user to ensure that the cable's braided screen is terminated to a suitable earth bonding point.

\* Optional – refer to the 'IcountPD part number specifier' section in this manual.

\*\* A standard USB serial adaptor can be used with the recommended 9-way D-type connector to convert RS232 to USB.

## Limit relay alarm levels

The IcountPD can be specified with a built-in limit switch relay which can be triggered when a preset alarm level is reached. The relay contacts can be used to switch on or off an external device.

M12 Supply and Relay (if fitted) cable

Pin	Current loop options connections	0-5v/0-3v option connections
1	Product supply 9-40Vdc	Product supply 9-40Vdc
2	4-20mA Supply 12-20Vdc	0-5 / 0-3V Supply 12-24Vdc
3	Relay (Normally Closed) <sup>***</sup> (if fitted)	Relay (Normally Closed) <sup>***</sup> (if fitted)
4	Relay (Normally Open) <sup>***</sup> (if fitted)	Relay (Normally Open) <sup>***</sup> (if fitted)
5	NOT USED	NOT USED
6	NOT USED	0-5V / 0-3V Supply 0 Vdc
7	Main supply 0Vdc	Product supply 0Vdc
8	Relay (Common) <sup>***</sup> (if fitted)	Relay (Common) <sup>***</sup> (if fitted)

Note: If the moisture sensor is fitted without either option then the output is RS232.

Parker Hannifin recommend that the mating M12 connector cables are screened. These cables are available from Parker Hannifin – ordering information section.

<sup>\*\*\*</sup> Optional – refer to ordering information section.

### (Limit Relay Wiring Instructions)

NORMALLY OPEN

NORMALLY CLOSED

COMMON

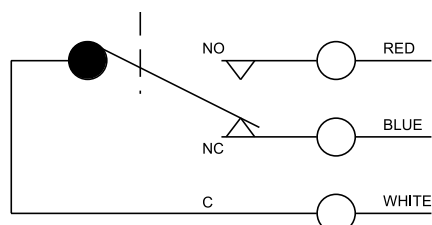

## Variable mA output settings

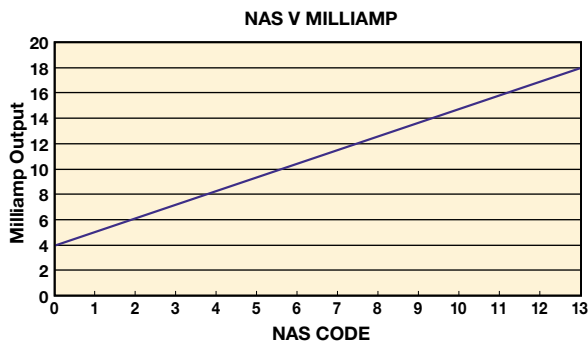
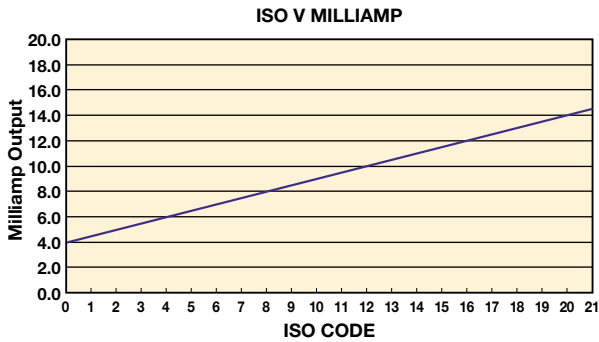

The following table can be used to equate the analogue output to an ISO or NAS Code.

Example ISO code 12 is equal to 10mA

mA	ISO	mA	NAS
4.0	0	4	00
4.5	1	5	0
5.0	2	6	1
5.5	3	7	2
6.0	4	8	3
6.5	5	9	4
7.0	6	10	5
7.5	7	11	6
8.0	8	12	7
8.5	9	13	8
9.0	10	14	9
9.5	11	15	10
10.0	12	16	11
10.5	13	17	12
11.0	14	18	**
11.5	15	19	**
12.0	16	20	ERROR
12.5	17		
13.0	18		
13.5	19		
14.0	20		
14.5	21		
15.0	**		
15.5	**		
16.0	**		
16.5	**		
17.0	**		
17.5	**		
18.0	**		
18.5	**		
19.0	OVERRANGE		
19.5	OVERRANGE		
20.0	ERROR		

The following table can be used to equate the analogue output to an ISO or NAS Code.

Example ISO code 12 is equal to 10mA

### 4-20mA output settings

#### ISO Setting

mA current = (ISO Code / 2) + 4 eg. 10mA = (ISO 12 / 2) + 4

or

ISO Code = (mA current - 4) \* 2 eg. ISO 12 = (10mA - 4) \* 2

#### NAS Setting

mA current = NAS Code + 5 eg. 15mA = NAS 10 + 5

or

NAS Code = mA current - 5 eg. NAS 10 = 15mA - 5

## Variable voltage output settings

The variable voltage output option has the capability of two different voltage ranges: a 0–5Vdc range as standard, and a user-selectable 0–3Vdc range. The ‘Full list of commands’ on how to change the voltage output, are available from Parker.

The following tables can be used to relate the analogue output to an ISO or NAS code.

For example, in a 0–5Vdc range, ISO code 16 is equal to an output of 3.5Vdc. In a 0–3Vdc range, ISO code 8 is equal to an output of 1.0Vdc.

Table relating ISO codes to Voltage output

ISO	Err	0	1	2	3	4	5	6	7	8	9	10	11
0–5Vdc	<0.2	0.3	0.5	0.7	0.9	1.1	1.3	1.5	1.7	1.9	2.1	2.3	2.5
0–3Vdc	<0.15	0.2	0.3	0.4	0.5	0.6	0.7	0.8	0.9	1.0	1.1	1.2	1.3

cont.

ISO	12	13	14	15	16	17	18	19	20	21	22	Err
0–5Vdc	2.7	2.9	3.1	3.3	3.5	3.7	3.9	4.1	4.3	4.5	4.7	>4.8
0–3Vdc	1.4	1.5	1.6	1.7	1.8	1.9	2.0	2.1	2.2	2.3	2.4	>2.45

Table relating NAS codes to Voltage output

ISO	Err	00	0	1	2	3	4	5	6	7	8	9	10	11	12	Err
0–5Vdc	<0.4	0.6	0.9	1.2	1.5	1.8	2.1	2.4	2.7	3.0	3.3	3.6	3.9	4.2	4.5	>4.6
0–3Vdc	<0.2	N.S.	0.3	0.5	0.7	0.9	1.1	1.3	1.5	1.7	1.9	2.1	2.3	2.5	2.7	>2.8

## Digital display parameters (ISO 4406/NAS 1638)

### Start up

1. Once the IcountPD has been connected to a regulated power supply, the product logo is displayed for approximately five seconds as the IcountPD performs a self system diagnostic check.
2. The IcountPD then automatically starts monitoring using factory default test parameters.



### Digital display indication

The digital display will show the actual measured codes, the channel ( $\mu$ ) size and the user definable limits. Note that the channel size and limits will alternate between the two.

The Moisture Sensor reading (%RH) will also be shown – if the Moisture Sensor option is fitted.

The order of trigger for both the codes and Moisture Sensor option is:

- Solid digit(s) = code(s) that are at or below the set point (limit)
- Flashing digit(s) = code(s) that are above the set point (limit)

The display for ISO4406 and NAS1638 are identical. The ISO display is shown below.

### Error detection:

In the unlikely event of a error occurring, the digital display on the IcountPD will simply display the actual error code only – i.e. ERROR 13 (A full list of error codes are detailed in the IcountPD User Manual).

### Moisture sensor output settings

The Moisture Sensor is an option that can be included when specifying the IcountPD.

The Moisture Sensor reports on the saturation levels of the fluid passing through the IcountPD sensing cell. The output is a linear scale, reporting within the range of 5% saturation to 100% saturation.

Table relating Saturation levels in the sensing cell to IcountPD outputs

Saturation	4–20mA	0–3Vdc	0–5Vdc
5%	4.8	0.15	0.25
25%	8	0.75	1.25
50%	12	1.50	2.50
75%	16	2.25	3.75
100%	20	3.00	5.00

# Icount<sub>PD</sub>

## Auxiliary Flow Device

The pressure compensated, Flow control device (Part Number S840074) has been developed to give the Icount<sub>PD</sub> user greater flexibility. The Flow control device will enable testing where flow ranges are outside the Icount<sub>PD</sub> specifications (40 – 140 ml/min), or where pipe diameters do not allow the Icount<sub>PD</sub> to be installed.

The Flow control device fits onto the downstream (outlet) side of the Icount<sub>PD</sub>, connecting through a manifold block, via a self-sealing quick connection test point and is fitted with a differential pressure valve.

This Flow control device automatically compensates for pressure and viscosity changes, whilst maintaining its setting even as the workload changes.

Simply position the valve to match the viscosity of the oil you are testing.

The chart below can be used to determine the valve position:



Valve Position	cSt Range
3	up to 100
3.8	90 - 200
4.2	190 - 320
5	310 - 500

Example:

If the fluid you wish to analyse has a viscosity of 50cSt under normal operating conditions then the control knob on the Flow Control Device should be set to valve position '3'

The flow device will now automatically control the flow rate through the Icount<sub>PD</sub> to within its working range of 40-140ml/min.

Note: The Flow control device will still operate correctly even with the high pressure side at 200bar and the return back to an open system of 0 bar (DP = 200bar)

## Hydraulic Connection Diagram

## Dimensions

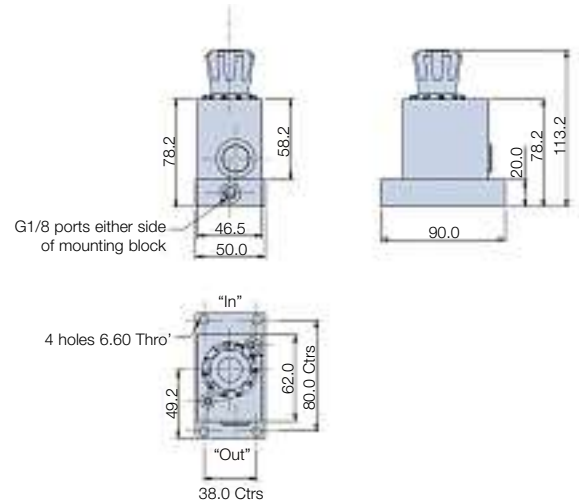
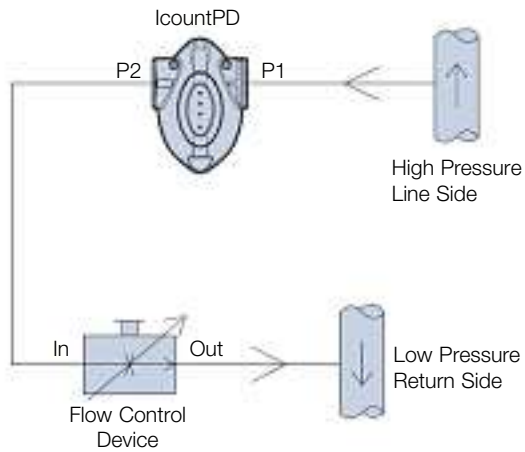

### Actuator

### Mounting Type

### Mounting position

### Weight

### Fluid Temperature

### Ambient storage temperature

### Viscosity range

### Differential pressure range

### Maximum pressure

### Flow direction

### Port thread detail

### Internal Seals

Manual flow rate adjustable via control knob

4 off mounting holes to suit M6 screws (not supplied)

Any

1.7kg (3.7lb)

5°C to +80°C (+41°F to 176°F)

-20°C to +40°C (-4°F to +104°F)

20cSt to 500cSt (If lower than 20cSt contact Parker)

5 to 315 bar

315 bar

'IN' to 'OUT' flow control function

1/8" BSPP (test points not supplied)

Viton





# Icount<sub>PD</sub>

## Communication Options

The IcountPD may be configured using the IcountPD Setup Utility. For more direct control of the device using its communications protocol, you may also use the Microsoft Windows® HyperTerminal program, but note that this program is not currently supplied with the Windows Vista™ operating system. These two ways of communicating with IcountPD are described in the following section.

### IcountPD Setup Utility software

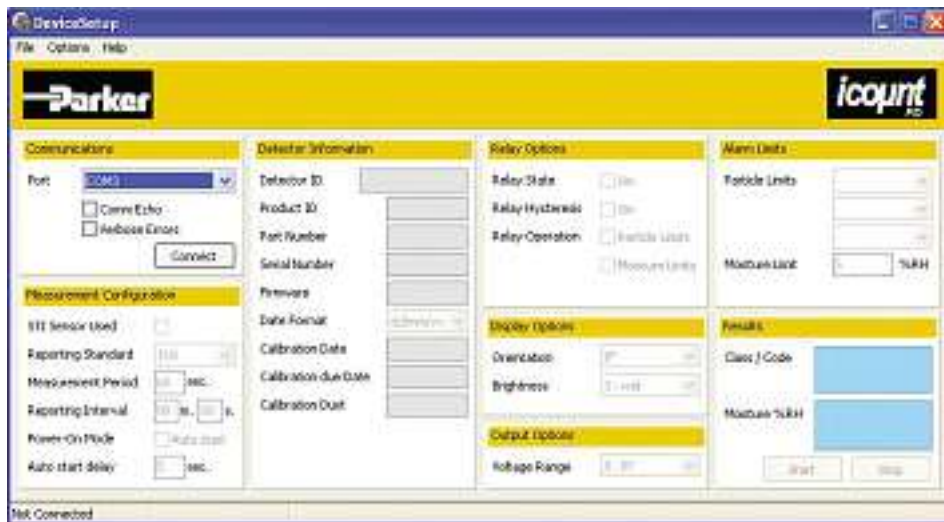

## Communication Protocol

The Communication protocol for the serial communication link is to be used with **Microsoft Windows HyperTerminal**. The settings are as follows:

Baud rate	9600
Data bits	8
Parity	None
Stop bits	1
Flowcontrol	None

The commands used with this product are made up of Read, Set and Start / Stop commands.

- Set commands allow the value or values of parameters to be set
- Read commands allow the value or values or parameters to be read
- Start/Stop allows the user to start and stop tests.

Example:

[SDF dd/mm/yy] - sets the date format.  
 [RDF] - reads the product date format.

All commands are sent in ASCII characters, and the protocol accepts both upper and lower case characters as the examples below:

SDF  
 SdF

Note: A full list of commands are detailed in the user manual

## Ordering Information

Standard Products Table

Part number	Fluid type	Calibration	Display	Limit relay	Communications	Moisture sensor	Cable connector kit	Future option
IPD12212130	Mineral	MTD	LED	No	RS232 / 4-20mA	No	M12 - 8 pin	N/A
IPD12212230	Mineral	MTD	LED	No	RS232 / 4-20mA	Yes	M12 - 8 pin	N/A
IPD12222130	Mineral	MTD	LED	Yes	RS232 / 4-20mA	No	M12 - 8 pin	N/A
IPD12222230	Mineral	MTD	LED	Yes	RS232 / 4-20mA	Yes	M12 - 8 pin	N/A
IPD12312130	Mineral	MTD	Digital	No	RS232 / 4-20mA	No	M12 - 8 pin	N/A
IPD12312230	Mineral	MTD	Digital	No	RS232 / 4-20mA	Yes	M12 - 8 pin	N/A
IPD12322130	Mineral	MTD	Digital	Yes	RS232 / 4-20mA	No	M12 - 8 pin	N/A
IPD12322230	Mineral	MTD	Digital	Yes	RS232 / 4-20mA	Yes	M12 - 8 pin	N/A

Product Configurator

Key	Fluid type	Calibration	Display	Limit relay	Communications	Moisture sensor	Cable connector kit	Future option
IPD	1 Mineral	1 ACFTD	1 None	1 No	1 RS232	1 No	0 No	0
	2 Aggressive	2 MTD	2 LED	2 Yes	2 RS232 / 4-20mA	2 Yes	1 Deutsch DT Series Connector	
	3 Aviation fuel hazardous areas	3 AS4059	3 Digital		3 RS232 / 0-5V		3 M12, 8 Pin Plug Connector*	
			4 GSM		4 RS232 / RS485			
	4 Aviation fuel non-hazardous area				5 RS232 / CAN(J1939)			

Accessories

Description	Part number	
	Mineral	Aggressive
1 metre hose length	B65946	B84827* *
2 metre hose length	B94802	B94801* *
5 metre hose length	B94804	B84828* *
Minimess 1/4" BSP fitting	P653109	P843081
Minimess 1/8" BSP fitting	P653110	P853008
Minimess 1/8" NPT fitting	P653512	P853005
Single point sampler	SPS2021	SPS2061
Internal flow device	S840074	Contact Parker
Power supply	B84829	
5 Metre, M12		
8 Pin Plug and Socket Cable Kit*	B84654	Contact Parker
Deutsch Connector Kit	P843130	
RS232 To USB Converter	B84011	

\* M12 Cable kit consists of two 5 metre cables to enable all output options (Communications cable and Relay/Power Supply cable)

\*\* Note that the aggressive fluid hoses are provided as a single hose, not in pairs.

Part number	Supercedes	Size	Flow range l/min	Fluid type	Port threads
STI0144100	STI.0144.100	0	6-25	Mineral	3/8
STI1144100	STI.1144.100	1	20-100	Mineral	3/4
STI2144100	STI.2144.100	2	80-380	Mineral	1 1/4
STI0148100	STI.0148.100	0	6-25	Aggressive	3/8
STI1148100	STI.1148.100	1	20-100	Aggressive	3/4
STI2148100	STI.2148.100	2	80-380	Aggressive	1 1/4

# H<sub>2</sub>Oil - Water in Oil Monitor



# H<sub>2</sub>Oil - Water in Oil Monitor

## Features & Benefits

- Water monitoring is now possible while machinery is working - H<sub>2</sub>Oil saves on production downtime.
- Totally portable, can be used easily in the field without the need for mains power, as well as in the laboratory.
- Connects into system at pressures up to 420 bar, via either system 20 sensor or single point sampler.
- 90 second test time.
- Scrolling memory for 500 tests plus memory for 20 different oil calibration curves.
- Routine water monitoring of oil systems with H<sub>2</sub>Oil saves time and money, promoting oil longevity.
- Samples that are tested are truly representative of water in the system. Analysis carried out before sample hydrodynamics change.
- Data entry facility enables user to store unique data test log details with every test carried out.
- Instant, accurate results are available on the display or the built-in printer ensuring maintenance decisions can be taken immediately.
- Computer interface available for downloading data on to the computer through the RS232 serial port.
- Internal diagnostics features ensures H<sub>2</sub>Oil will work accurately and reliably.
- Supplied in a robust aluminium carrying case.
- Optional oil delivery kit for simple offline sampling (see fig.1) .



Fig.1

## Typical Applications

- Off-shore & power generation
- Marine
- Construction machinery
- Paper mills
- Hydraulic equipment & system manufacturers
- Research & testing institutes
- Military equipment application

The H<sub>2</sub>Oil is a two channel non-dispersive absorption spectrometer, designed to measure the level of water content polluting the oil, reducing system efficiency, promoting wear and affecting safety.

The H<sub>2</sub>Oil makes it possible for an end user or service engineer to carry out quick, accurate measurements, taken in the field instead of remote laboratory analysis.

With its secured hoses the H<sub>2</sub>Oil connects to an in-line System 20 sensor or single point sampler and features a re-chargeable 12Vdc power pack, diagnostic computer and on-board printer for effective logging and retrieval of data.



## Specification

### Construction:

Case-Noryl structural foam and ABS printer cover. Key pad silicone rubber.

### Mechanical composition:

Brass, plated steel, stainless steel.

### Seals:

Fluorocarbon.

### Hoses:

Nylon (Kevlar braided microbore).

### Hose length:

Fluid connection hose 1.2 metre (3.9 feet).

### Flow rate:

Up to 400 l/min (100 US GPM).

(System 20 Sensors). Higher flows with SPS.

### Max. working pressure:

Up to 420 Bar (6000 psi).

### Fluid compatibility:

Mineral oil and petroleum based fluids.

### Power:

Re-chargeable battery pack (12Vdc trickle charger supplied).

### Fuse:

5.0 amp fast blow fuse included for overload protection.

### H2Oil technology:

Infrared absorption spectroscopy

### Measurement and range:

PPM (0-3000) or % content.

### Max operating temperature:

+5°C to +80°C (+41°F to +176°C).

### Environmental temperature:

+5°C to +40°C (+41°F to +104°F).

### Test completion time:

90 seconds.

### Memory store:

500 TEST (scrolling memory) capacity.

### Printer facility:

Integral 16 column thermal printer for hard copy data.

Computer interface RS232.

### Repeatability/accuracy:

Better than 5% (typical).

### Viscosity range:

2-100 cSt (9-460 SSU). 500cSt with SPS.

### Commissioning kit:

Includes 2 re-chargeable battery packs (1 fitted to monitor), 2 x thermal printer rolls, spare fuse, screwdriver, 12Vdc trickle charger and user manual.

### Data entry:

24 character two line back lit dot matrix LCD. Full alpha numeric keypad.

### Data retrieval:

Memory access gives test search facility.

### Monitor carry case:

Robust padlockable aluminium presentation case.

### Datum:

Condition monitoring data software pack plus cable included in commissioning kit.

### Performance recheck:

Annual recheck of performance by an approved Parker Service Centre.

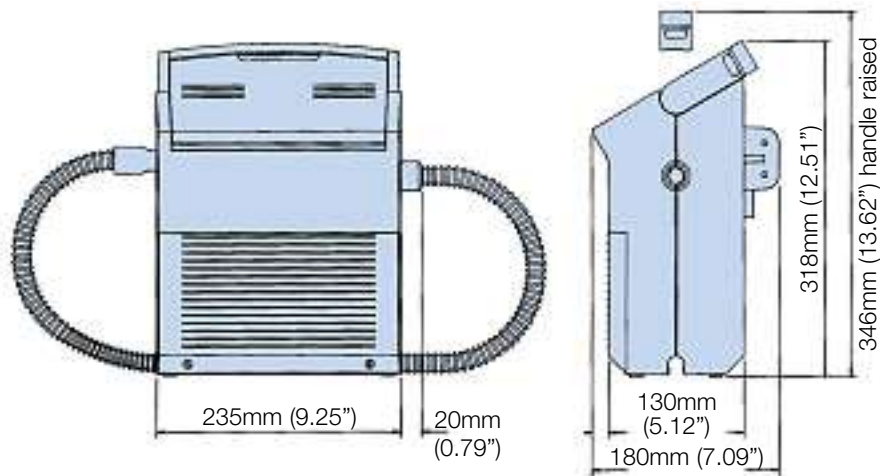

# H<sub>2</sub>Oil - Water in Oil Monitor

## How the H<sub>2</sub>Oil Works

On-line testing allows a mixed and flowing sample of oil and water to pass through the infrared measuring cell. A series of measurements can be taken and the average given as a result. With this method a representative oil sample is seen, unlike the usual reservoir samples sent for analysis. Also, by taking the test at working temperature and pressure, a true water content is taken, as both affect the way water is absorbed in oil.

The flowing sample passes through a special "water free" optical cell.

The infrared detector monitors two narrow band pass filters, one of which matches the spectral width of the water attenuation band. The second narrow wave band selected is unaffected by water and serves as a reference. By taking the transmission ratio between the two points an effective measurement of water can be made.

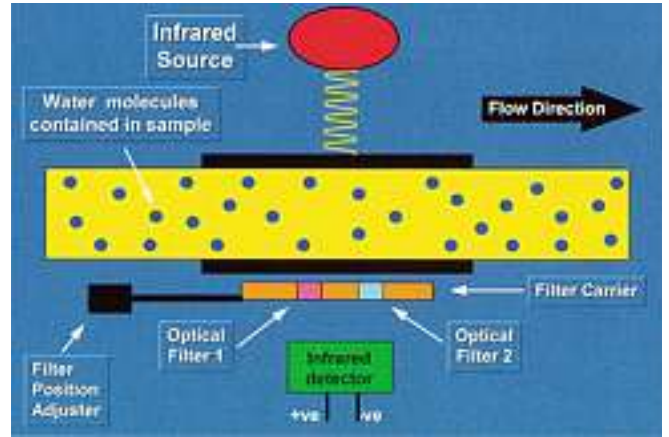

## Core Technology

H<sub>2</sub>Oil uses true infrared (IR) analysis technique - the principle used in all laboratory spectrometers, to measure absorbed water (before saturation point).

Channel one (2.6μ) is the reference point, whereas channel two (3μ) is H<sub>2</sub>O.

The IR source is a tungsten halogen bulb.

## Effective Oil Maintenance

Take a typical application where water can have a very detrimental effect on bearings. Cracks are generated early in life of a bearing and water, once condensed in the crack, leads to corrosion and early damage.

Loss of bearing life, due to water contamination, (see below) can be prevented by stopping the water from entering the system in the first place. Introducing a regular water content monitoring function into the programme, such as the H<sub>2</sub>Oil, would support such efforts.

Whatever the application, whether it be offshore in the oil industry or off-road in the construction or earth moving industry, the portability of the H<sub>2</sub>Oil makes it an essential kit for the service van or engineers tool.

## Ordering Information

### Standard products table

Product number	Supersedes	Description
<b>WOM9100</b>	N/A	H <sub>2</sub> Oil (includes aluminium case and kit)
<b>B91701</b>	B.91.701	Printer paper (5 rolls)
<b>S840134</b>	N/A	Oil delivery unit
<b>B84779</b>	B.84.779	Datum download software
<b>B91706</b>	B.91.706	Cable and adaptor

Note 1: Part numbers featured with bold highlighted codes will ensure a 'standard' product selection.

Note 2: Alternate displayed part number selection will require you to contact Parker Filtration for availability.

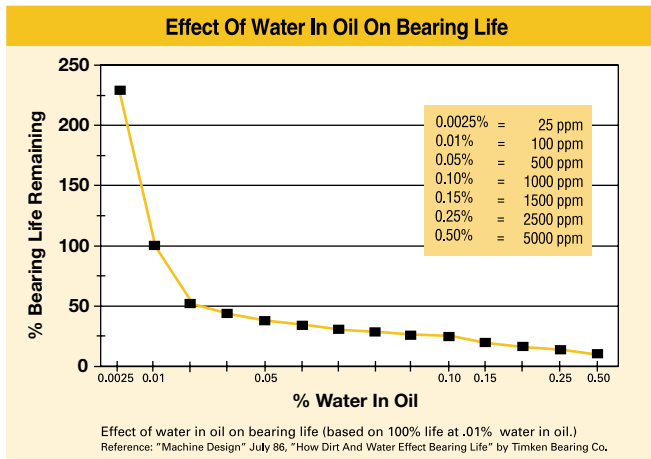

# MOISTURE SENSOR RANGE



# Moisture Sensor Range

## Features & Benefits

- Continuous, online moisture indication, for hydraulic and lubricating systems.
- Reporting of % relative humidity of water content, giving the user information on how close to the fluids real saturation point.
- Reliable data on the rate of water absorption.
- Sensing cell technology using a laser trimmed thermoset polymer, for capacitive sensing that is capable of absorbing water molecules due to its micro porous structure.
- Uses a thermistor for temperature compensation correction. Offering total confidence in reporting the %RH relative humidity over the sensors temperature range.
- A purpose designed tee adaptor allows for easy installation into an existing fluid system.
- The MS200 can also be specified with a bench top wand offering the end user greater flexibility.
- Not available on M5150

## Typical Applications

- Ground support vehicles
- Pulp and paper plants
- Marine hydraulics
- Power transmission & distribution
- Forestry
- Industrial hydraulics
- Earth moving applications
- Agricultural
- Hazardous Areas (Zone 2)
- Theme parks (Ride hydraulics)



## In-Line Moisture Measurement of Hydraulic & Lubricating Oils.

Parkers Moisture Sensor Range offers fast, reliable and accurate in-line detection of moisture in fluids. The MS transducer type technology has been especially designed with the preventative maintenance programme environment in mind.

The industry accepted sensing cell device will monitor and report Relative Humidity (RH), moisture content in oils. The water content measurement technique offers the end user benefits over the current standard form of water content reporting (PPM).

This allows for real time preventative maintenance to be undertaken and corrective actions to be made. By knowing that the water contamination is still within the oils absorbing range, less than 100%, reclaiming fluid properties before additive damage occurs can initiate calculable cost savings.





# MS150 Moisture Sensor

## Specification

### Pressure:

Maximum allowable operating pressure. (MAOP): 10 bar (145 PSI).

### Operating temperature:

Minimum: -20°C (-4°F).  
Maximum: +85°C (+185°F).

### Flow through sensor cell:

Installed in active flowstream.

### Fluid compatibility:

Mineral oils, petroleum-based and Phosphate ester.

### Viscosity range:

Unlimited.

### Port connections:

1/4" BSPT or 1/4" NPT.

### Supply voltage:

+8 to +30 Vdc.

### Sensor size/weight/material:

80mm x 43mm/0.1kg/Aluminium

### IP ratings:

IP68

### %RH Outputs:

(+1 to +5 Vdc) or (+4 to 20mA)

### Temperature Outputs:

0 to +5 Vdc

## Installation Details

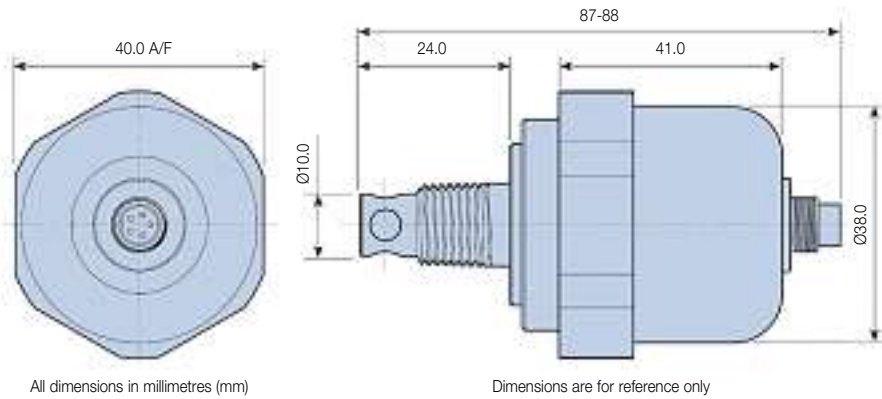

## Thread Form Options

### BSPT

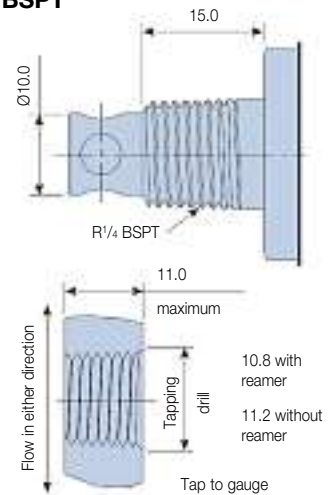

### NPT

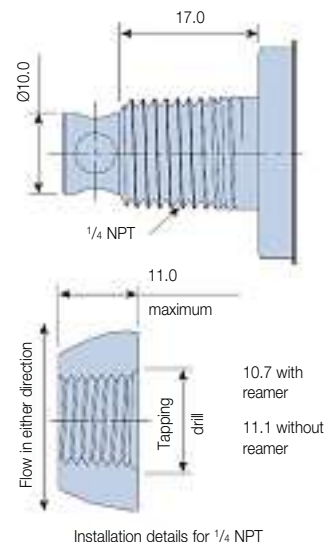

## Sensor Outputs

MS150 moisture sensor pin designations

Pin	Designation	I/O	Description
1	Supply	Input	Supply voltage (+8 to +30Vdc)
2	%RH	Output	% Saturation out (+1 to +5Vdc)
3	%RH	Output	% Saturation out (+4 to +20mA)
4	Temperature	Output	Temperature out (0 to +5Vdc)
5	Common	Input	Common (0Vdc) ground from power supply (not chassis ground)

## Interpreting the data

Oil type: Texaco Rando 46.

Saturation point: 400ppm @ 65°C (150°F).

At the above operating condition, the meter displays 100% saturation. As the meters scale indicates a reduction in the saturation percentage, there is also a corresponding reduction in PPM at a constant temperature. In the example above, a meter reading of 50% saturation could be interpreted as 200ppm at 65°C (150°F).

# MS200 'Programmable'

## Specification

% Saturation Calibration Accuracy:	+3% RH
Temperature Calibration Accuracy:	±1°C
Thermal Stability:	±1% RH (over compensated temperature range +10 to +80°C)
Stability:	±0.2% RH typical at 50% RH in 1 year
Linearity:	±0.5% RH typical
Analogue Output Hysteresis:	±0.5% RH Full Scale
Switched Output Hysteresis:	2% RH
Operating Temperature Range:	-40°C to +85°C (-40 to +185°F)
Operating Humidity Range:	5 to 100% RH (non condensing)
Response Time:	60 sec in slow moving air at 25°C
Maximum rated pressure:	420 Bar (6000 PSI)
Maximum torque on spanner flats:	30 Nm (ONLY USE SPANNER FLATS TO INSTALL AND REMOVE THE MOISTURE SENSOR)
Seal Material (depending on MS):	Fluorocarbon, EPDM, Perfluoroelastomer
Material:	Stainless Steel 303
Connector Details:	M12x1, 8 Way, IP67 Connector (IP68 when mated)
Maximum Cable Length:	10 Metres with Voltage Output 100 Metres with Current Output
Output:	SEE ORDERING INFORMATION

## Installation Details

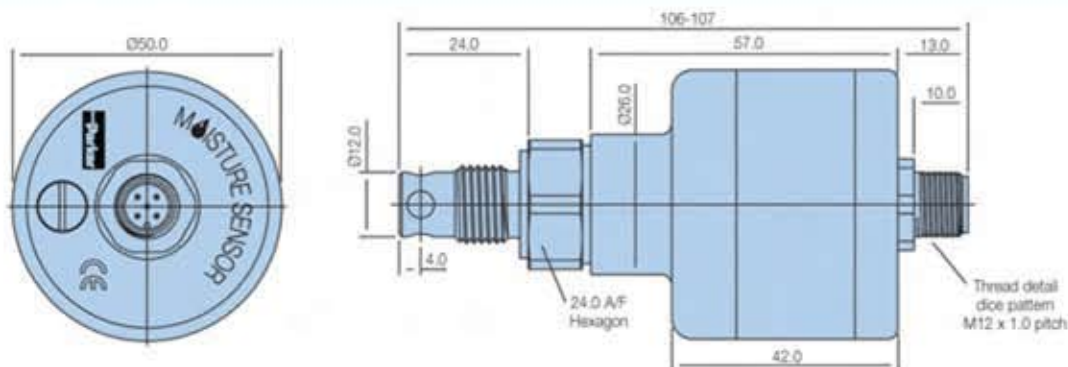

## Moisture Sensor Wiring and Pin Designations

Pin	Wire Colour	Designation	I/O	Description
1	Brown	Analogue	Output	Temperature - DegJ Celsius. User Select Output (0-3Vdc, 0-5Vdc, 1-6Vdc and 4-20mA).
2	Green	Alarm Limit	Output	Alarm Limit. Output that directly corresponds to the alarm set point.
3	Yellow	Analogue	Output	% Saturation. User Select Output (0-3Vdc, 0-5Vdc, 1-6Vdc and 4-20mA).
4	Grey	Receive	Input	RS232 Communication.
5	Pink	Send	Output	RS232 Communication.
6	Blue	Common	Input	Common (0Vdc). Ground from power supply.
7	White	Alarm Switch	Output	Alarm Switch. Constant 5Vdc when in normal operation. Switch to 0Vdc when in alarm condition. Red LED illuminates when Sensor is in an alarm condition.
8	Red	Supply	Input	Supply Voltage (+8 to +30Vdc). Green LED illuminates when power is properly applied.

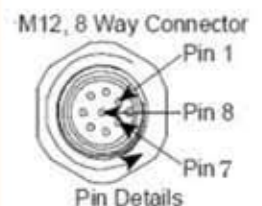

# MS300 Intrinsically Safe

## Specification

### Pressure:

Maximum allowable operating pressure.  
(MAOP): 420 bar (6000 PSI).

### Operating temperature:

Minimum: -40°C (-40°F) - dependent on seal material.  
Maximum: +85°C (+185°F).

### Flow through sensor cell:

Installed in active flowstream.

### Fluid compatibility:

Mineral oils, petroleum-based and Phosphate ester-Skydrol option available.

### Viscosity range:

Unlimited.

### Thread form connections:

See ordering information.

### Outputs:

4-20mA (current loop).

### Calibration accuracy:

+/- 5% RH

### Compensated thermal stability:

+/- 1% RH (+ 10°C to +80°C)

### Materials:

Stainless steel 303.

### Sensor size/weight:

107mm x ø50mm/0.3Kg.

### IP ratings:

IP68 (with specified moulded cable)

Developed in association with Triteq Ltd.

## Installation Details - See MS200



### Moisture Sensor Connection Diagram

1. Supply (4-20 mA - IN)	- Brown	1
2. Signal (4-20 mA - OUT)	- White	2
3. Not Used	- Blue	3
4. Not Used	- Black	4
5. Not Used	- Grey	5

The MS300 has been certified as Intrinsically Safe Electrical Apparatus and offers fast, reliable and accurate in-line detection of moisture in fluids for use in hazardous areas.

ATEX Certification allows the MS300 into areas of a potentially explosive atmosphere, that have previously not been allowed without permits, it is intended for use in Zone 0 hazardous areas requiring the use of category 1G equipment and has been designed for use with galvanic isolators to the specified values stated below:

The electrical parameters: Ui: 28V li: 93mA Pi:0.65W Ci: 380nF Li: 0

The following instructions apply to MS300 - 4-20mA Current Loop Moisture Sensor covered by certificate number Sira 07ATEX2255:

1. The equipment may be located where flammable gases of Group I may be present. The equipment is only certified for use in ambient temperatures in the range -20°C to +40°C and should not be used outside this range.
2. The equipment has not been assessed as a safety-related device (as referred to by Directive 94/9/EC Annex II, clause 1.5).
3. Installation of this equipment shall be carried out by suitably trained personnel in accordance with the applicable code of practice.
4. Repair of this equipment shall be carried out by the manufacturer or in accordance with the applicable code of practice (IEC 60079-19).

## Visual Indicators Specifications

### Bar Graph Indicator (PBG8341A)

#### Construction:

Housing – nylon 6/6, window – acrylic,  
bezel/board supports – ABS,  
pins – phosphor bronze.

#### Power supply:

11 – 30 Vdc.

#### Signal input: (By dipswitch configuration)

Off – differential up to 5V.  
A – single signal (Ref. 0V) up to 5V.  
B – single signal (Ref. 1V) up to 6V.

#### Cut out size:

45.6mm x 45.6mm.

#### Fixing:

Push fit panel thickness 0.9mm to 3.2mm.

#### Sealing:

Designed to IP50 standard.  
(Front face may be silicon sealed after LED configuration).

#### Scale:

Supplied 0 to 100% in horizontal.  
Other scales, in volume, consult Parker Hannifin.

#### Scaling factors:

10% to 100% range. Fully adjustable.

#### Lamp intensity:

4mcd each.

#### Front viewing:

Polarised.

#### Weight:

29gms.

### Alternative Indicator

Description	DDU1001	DDU1002
Power supply	22 - 55 Vdc	110 - 240 Vdc
Accuracy	± 0/01% typical	± 0.1% typical
Sample rate	10 per second	2.5 per second
Operating temp (°C)	0 - 55	0 - 50
Storage temp (°C)	-10 to +70	-10 to +70
Display	5 digit LED	3½ digit LED
Power output (Vdc)	24	24
Weight (kg)	0.21	0.30
Panel cutout (mm)	92x48 ±0.5	93x45 ±0.5
Dimensions (mm)	48x96x100	48x96x93



DDU1001



DDU1002



PBG8341A

### Product accessories part numbers

Product Number	Supersedes	Description	MS150	MS200	MS300
P9732PVC10	P.9732PVC-10	10 meter M12 IP68 PVC coated cable	Y	N	Y
P9732PVC05	P.9732PVC-05	5 meter M12 IP68 PVC coated cable	Y	N	Y
P9732PVC02	P.9732PVC-02	2 meter M12 IP68 PVC coated cable	Y	N	Y
P9732PUR10HS	N/A	10 meter M12 5 way high specified PUR coated cable	N	N	Y
P9732PUR10	P.9732PUR-10	10 meter M12 IP68 PUR coated cable	Y	N	Y
P9732PUR05	P.9732PUR-05	5 meter M12 IP68 PUR coated cable	Y	N	Y
P9732PUR02	P.9732PUR-02	2 meter M12 IP68 PUR coated cable	Y	N	Y
DDU1001	DDU-1001	+22 to +55 Vdc process indicator	Y	Y	Y*
DDU1002	DDU-1002	+110 to +240 Vac process indicator	Y	Y	Y
PBG8341A	PBG.8341.A	+11 to +30 Vdc bar graph indicator	Y	Y	Y*
B97200	N/A	5 meter M12 x 1, 8 way moulded cable (IP68)	N	Y	N
P973200	N/A	5way Re-wireable M12 connector (IP65)	Y	N	N
S970400	N/A	12 Vdc power supply	Y	Y	N
S970410	N/A	10 meter extension box	Y	Y	N
PAM8342	PAM.8342	Alarm module			

\* Only for use in a safe zone (ie laboratory)

## Moisture sensor output setting

The Moisture sensor reports on the saturation levels of the fluid passing through the sensing cell. The output is a linear scale, reporting within the range of 5% saturation to 100% saturation.

Saturation	4–20mA	0–3Vdc	0–5Vdc
5%	4.8	0.15	0.25
25%	8	0.75	1.25
50%	12	1.50	2.50
75%	16	2.25	3.75
100%	20	3.00	5.00

## Ordering Information

MS150 Standard Product Table

Product Number	Supersedes	Fluid type	Thread Forms	Connector
<b>MS1503</b>	MS150-3	Mineral + Aggressive	G 1/4" BSPT Taper	M12 5 WAY
<b>MS1504</b>	MS150-4	Mineral + Aggressive	1/4" NPT Taper	M12 5 WAY

MS200 - Product Configurator

Key	Model	Fluid type	Output Options	Thread Forms	Connector	Intrinsically Safe
<b>MS</b>	2 Programmable	2 Mineral	01 0 - 3 Vdc	1 G 1/4" BSP Bonded Seal	1 M12 8 WAY	0 No
			02 0 - 5 Vdc	2 G 1/4" BSP Integral Seal		
		6 Aggressive	03 1 - 6 Vdc	3 R 1/4" Taper Thread		
			04 4 - 20 mA	4 1/4" NPT Taper Thread		
		5 9/16 - 18 UNF 2A Integral Seal				
		6 Hand Held Unit				
		7 G 3/8" BSP Female Swivel Equal Tee				

Standard Product Table

Key	Model	Fluid type	Output Options	Thread Forms	Connector	Intrinsically Safe
<b>MS</b>	<b>2</b>	<b>2</b>	<b>02</b>	<b>1</b>	<b>1</b>	<b>0</b>
<b>MS</b>	<b>2</b>	<b>2</b>	<b>04</b>	<b>1</b>	<b>1</b>	<b>0</b>

MS300 - Product Configurator

Key	Model	Fluid type	Output Options	Thread Forms	Connector	Intrinsically Safe
<b>MS</b>	3 ATEX Compliant	2 Mineral	04 4 - 20 mA	1 G 1/4" BSP Bonded Seal	2 M12 5 WAY	0 Yes
				2 G 1/4" BSP Integral Seal		
		6 Aggressive		3 R 1/4" Taper Thread		
				4 1/4" NPT Taper Thread		
		5 9/16 - 18 UNF 2A Integral Seal				
		6 G 3/8" BSP Female Swivel Equal Tee				

Standard Product Table

Key	Model	Fluid type	Output Options	Thread Forms	Connector	Intrinsically Safe
<b>MS</b>	<b>3</b>	<b>2</b>	<b>04</b>	<b>1</b>	<b>2</b>	<b>0</b>



# Oilcheck



# Oilcheck

## Features & Benefits

- A comparator between new and used oils.
- Oilcheck gives early warning of impending engine failure.
- Cost effective solution to save money and help increase engine life.
- Completely portable, battery powered.
- Ideal for fleet owners, garages and DIY mechanics.
- Numerical display to show positive or negative increase in dielectrics.

## Using Oilcheck

Following the simple sampling procedure. The Oilcheck will ensure effective and highly repeatable results. Once a clean oil sample has been placed in the 'Sensor Well' and the 'TEST' button has been pressed, the instrument will 'zero' on the sample.

Once cleaned out with a degreaser and replaced by a contaminated sample, a new reading is obtained on the LCD, which can be easily compared against the green/amber/red efficiency scale.

## Typical Applications

- Fleet owners
- Construction equipment maintenance
- Vehicle service garages
- Plant hire maintenance

The Oilcheck from Parker Filtration's Condition Monitoring Centre detects and measures the dielectric constant of oil, by comparing the measurements obtained from used and unused oils of the same brand.

Used as a regular service monitoring instrument, the Oilcheck will give the engineer warning of an impending engine failure and promote increased engine life. Oilcheck is the low-cost solution that will take the guesswork out of oil changes, saving money and time.





## Specification

**Case construction:**  
ABS.

**Circuitry:**  
Microprocessor control.

**Battery:**  
1 x 9V alkaline.

**Display:**  
LCD.

**Suitable oil types:**  
Mineral and synthetic based oils.

**Repeatability:**  
Better than 5%.

**Readout:**  
Green/amber/red grading, Numerical value (0-100).

**Battery lifetime:**  
>150 hours or 3,000 tests.

**Dimensions:**  
250mm x 95mm x 34mm (9.8" x 3.7" x 1.3").

**Weight:**  
0.4kg.

## Using Oilcheck



Green/amber/red numerical value



Function buttons

The Oilcheck can remove the need for costly and time consuming laboratory analysis of mineral and synthetic oils used in engines, gearboxes and bearing lubrication systems. It detects mechanical wear and any loss of lubricating properties in the oil with a repeat accuracy of less than 5%.

The Oilcheck is able to show changes in the oil condition brought about by the ingress of water content, fuel contamination, metallic content and oxidation.

## Installation Details

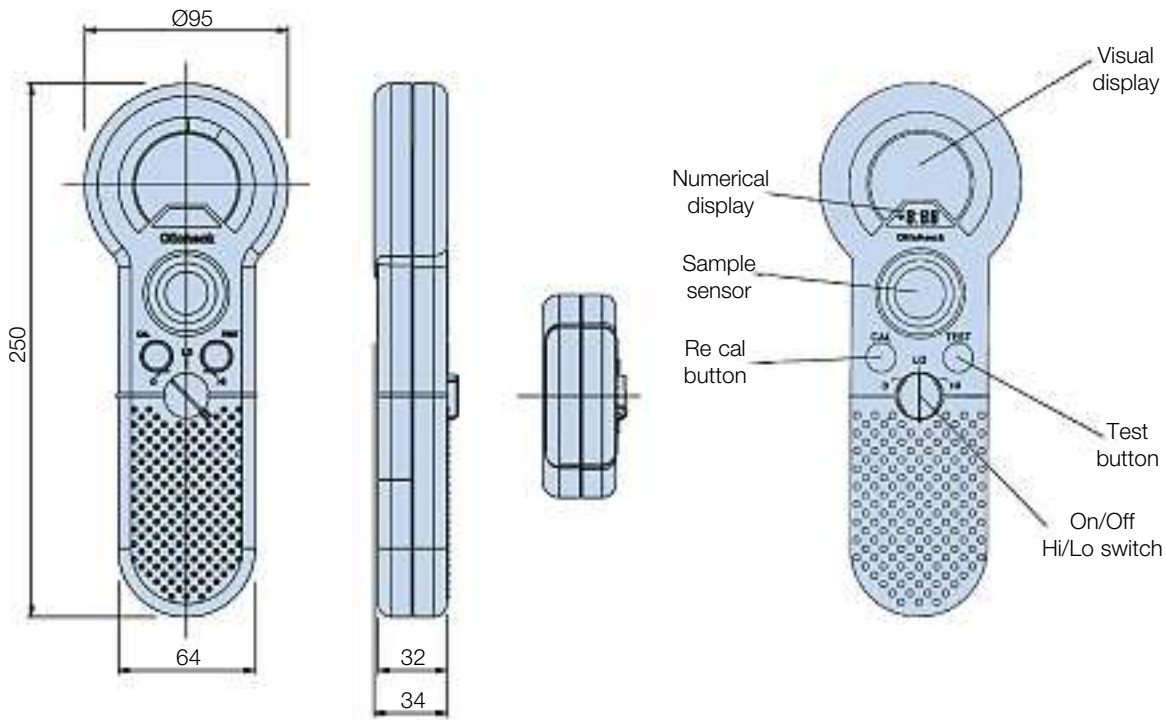

## Ordering Information

### Standard products table

Product number	Description
<b>OLK605</b>	Oilcheck kit with numerical readout
<b>OLK611</b>	Oilcheck cleaner

Note 1: Part numbers featured with bold highlighted codes will ensure a 'standard' product selection.

Note 2: Alternate displayed part number selection will require you to contact Parker Filtration for availability.



# ASIC 'Performer'

25, 60, 100, 250, 400 and 600 bar



# ASIC 'Performer'

## Applications for the ASIC Performer

- Fork lift trucks - braking and load systems.
- Truck mounted cranes - load safety systems.
- Earth moving machinery - hydraulic gearbox control.
- Racing car - gearbox, fuel, cooling and suspension systems.
- Water usage systems - pressurised systems for industrial and hi-rise usage.
- Forest Machinery - felling and logging.
- Paper mills - speed control and weighing systems.



### The Parker Filtration ASIC Performer Pressure Transducers and Transmitters.

The ASIC Performer offers a wide range of pressure sensors for mobile or industrial applications.

These sensors have been designed for the requirements of industrial instrumentation systems. Accordingly, the housings and all components in contact with the medium are made of stainless steel. Thus giving compatibility with a wide range of media. There is a choice of two plug connectors of either DIN or M12. There are

six measuring ranges available and a choice of outputs in the form of either voltage or current signals. Sensors with output signals from 4...20 mA are available in two wire technology.



The built-in voltage regulator allows the sensors to be operated with a supply voltage of 12-36/9-36 Vdc. All sensors are manufactured in our own production facility, typical of Parker Hannifin's continued commitment to flexibility and quality.



The Complete Performer range utilises ASIC technology (Application Specific Integrated Circuit) programmable software.



A comprehensive range of Pressure Transducers and Transmitters are available from Parker Filtration.

- One-piece body and diaphragm machining ensures long-term product stability.
- All stainless steel construction.
- 6 transducer pressure ratings with 0-5Vdc and 1-6Vdc outputs.
- 6 transmitter pressure ratings with a 2-wire 4-20mA output.
- Microdin plug and M12 connector options.



AC/DC display unit (DDU1002)

## Specification

**Pressure ranges:**  
25, 60, 100, 250, 400, 600 bar.

**Pressure Tolerance Specifications:**

Rating	Maximum Overload Pressure	Maximum Burst Pressure
25	x 6.0 (150 bar)	x 20.0 (500 Bar)
60	x 2.5 (150 Bar)	x 8.0 (500 Bar)
100	x 2.5 (250 bar)	x 5.0 (500 Bar)
250	x 4.0 (1000 Bar)	x 7.0 (1800 Bar)
400	x 2.5 (1000 Bar)	x 4.5 (1800 Bar)
600	x 1.5 (1000 Bar)	x 3.0 (1800 Bar)

**Vibration resistance:**  
IEC 60068-2-6:  
+/- 5mm/10Hz...32Hz  
200m/s<sup>2</sup> / 32Hz...2kHz

**Installation:**  
Spanner size 22A/F.  
Max. (recommended) tightening torque = 30Nm.

**Weight:**  
200 - 230g

**Lifespan:**  
10 million cycles

## Thread Forms

G<sup>1</sup>/<sub>4</sub> (1/4BSP) with ED seal.  
All thread forms and sensor interface are made from 1.4301 stainless steel.  
Non standard threads - contact Parker CMC

## Electrical

**Supply voltage**                      **Output**  
12 - 36Vdc                              0 - 5Vdc  
12 - 36Vdc                              1 - 6Vdc  
9 - 36Vdc                                4 - 20mA  
**Transducer current draw = <6mA**  
**Load impedance (ohm) = >10K**  
**Output signal noise = 0.1%FS**

## Product Performance

**Linearity:**  
Typical: 0.3%FS.  
Max: 0.6%FS.  
**Hysteresis:**  
Typical: 0.1%FS.  
Max: 0.25%FS.  
**Repeatability:**  
Typical: 0.2%FS.  
Max: 0.4%FS.  
**Functional temp range:**  
-40°C to +85°C.  
**Compensated temperature:**  
-20°C to +85°C.  
**Stability:**  
<0.1%FS/a (typ).  
**Response time:**  
= <1mS.

## Wiring Information

**Connector**  
**Industrial Micro Din**  
**9.4mm**

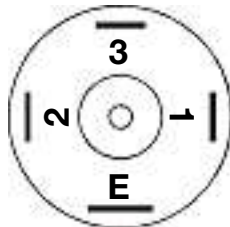

PIN	4 - 20mA	0 - 5Vdc	1 - 6Vdc
1	Do not connect	Signal output	Signal output
2	Supply +ve	Supply +ve	Supply +ve
3	Do not connect	Do not connect	Do not connect
E	Return	Supply ref. (0v)	Supply ref. (0v)

**Connector**  
**M12**

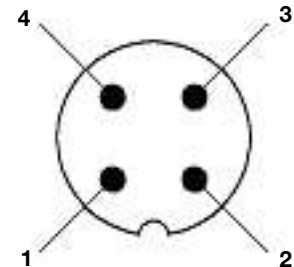

PIN	4 - 20mA	0 - 5Vdc	1 - 6Vdc
1	Supply +ve	Supply +ve	Supply +ve
2	Do not connect	Signal output	Signal output
3	Return	Supply ref. (0v)	Supply ref. (0v)
4	Do not connect	Do not connect	Do not connect

## Installation Details

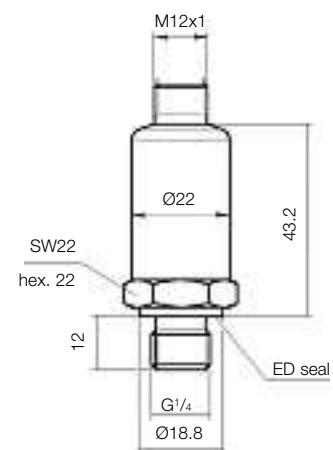
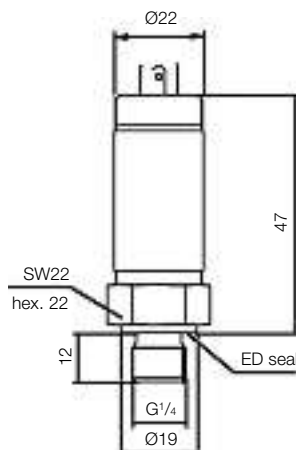

# ASIC 'Performer'

## Ordering Information

### Standard products table

Product number	Description - pressure transducer	Model	Output	Pressure	Thread form	Connector
<b>PTDVB2501B1C1</b>	0 - 5 Vdc 250 bar 1/4 BSP ED seal micro-din	PTD	VB	250	1	B1C1
<b>PTDVB4001B1C1</b>	0 - 5 Vdc 400 bar 1/4 BSP ED seal micro-din	PTD	VB	400	1	B1C1
<b>PTDVB2501B1C2</b>	0 - 5 Vdc 250 bar 1/4 BSP ED seal M12	PTD	VB	250	1	B1C2
<b>PTDVB4001B1C2</b>	0 - 5 Vdc 400 bar 1/4 BSP ED seal M12	PTD	VB	400	1	B1C2
<b>PTDVB0251B1C1</b>	0 - 5 Vdc 25 bar 1/4 BSP ED seal micro-din	PTD	VB	025	1	B1C1
<b>PTDVB0251B1C2</b>	0 - 5 Vdc 25 bar 1/4 BSP ED seal M12	PTD	VB	025	1	B1C2

Product number	Description - pressure transmitter	Model	Output	Pressure	Thread form	Connector
<b>PTXB4001B1C2</b>	4 - 20 mA 400 bar 1/4 BSP ED seal M12	PTX	B	400	1	B1C2
<b>PTXB0251B1C1</b>	4 - 20 mA 25 bar 1/4 BSP ED seal micro-din	PTX	B	025	1	B1C1
<b>PTXB0251B1C2</b>	4 - 20 mA 25 bar 1/4 BSP ED seal M12	PTX	B	025	1	B1C2
<b>PTXB4001B1C1</b>	4 - 20 mA 400 bar 1/4 BSP ED seal micro-din	PTX	B	400	1	B1C1
<b>PTXB2501B1C1</b>	4 - 20 mA 250 bar 1/4 BSP ED seal micro-din	PTX	B	250	1	B1C1
<b>PTXB2501B1C2</b>	4 - 20 mA 250 bar 1/4 BSP ED seal M12	PTX	B	250	1	B1C2

### Accessories

Product number	Supersedes	Description
<b>P833PVC2M</b>	P.833PVC-2M	2 meter PVC coated 4 core cable
<b>P833PVC5M</b>	P.833PVC-5M	5 meter PVC coated 4 core cable
<b>P833PVC10M</b>	P.833PVC-10M	10 meter PVC coated 4 core cable

Note 1: Part numbers featured with bold highlighted codes will ensure a 'standard' product selection.  
 Note 2: Alternate displayed part number selection will require you to contact Parker Filtration for availability.

### Product configurator

Product number	Output options		Pressure range (bar)		Thread form		Connector	
	Code	Description	Code	Description	Code	Description	Code	Description
<b>PTD</b>	<b>VB</b>	0 - 5 Vdc	<b>025</b>	0 - 25	<b>1</b>	1/4 BSP with ED seal	<b>B1C1</b>	Micro-din
<b>PTX</b>	<b>SB</b>	1 - 6 Vdc	060	0 - 60			<b>B1C2</b>	M12
	<b>B</b>	4 - 20mA (PTX only)	100	0 - 100				
	<b>RB</b>	0.5 - 4.5 ratiometric	<b>250</b>	0 - 250				
	<b>PB</b>	0.1 - 4.9	<b>400</b>	0 - 400				
			600	0 - 600				

Note 1: Part numbers featured with bold highlighted codes will ensure a 'standard' product selection.  
 Note 2: Alternate displayed part number selection will require you to contact Parker Filtration for availability.

### Examples of standard part number product ordering

**PTDVB2501B1C1** 0 – 5 volt output transducer  
 250 bar maximum pressure  
 1/4" BSP with ED seal  
 Industrial micro-din 9.4mm connector

**PTXB0251B1C2** 4 – 20mA output transmitter  
 25 bar maximum pressure  
 1/4" BSP with ED seal  
 M12 connector  
 (See accessories for IP68 protected cable)

**PTDSB4001B1C2** 1 – 6 volt output transducer  
 400 bar maximum pressure  
 1/4" BSP with ED seal  
 M12 connector  
 (See accessories for IP68 protected cable)

# ACM20 Lab Unit



# ACM20 Lab Unit

## Features & Benefits

**Test Time:**

2 minutes

**Repeat Test Time:**

Every 2 minutes (Manual testing)

**Principle of Operation:**

Optical scanning analysis and measurement of actual particles and inference to water presence

**Primary Output:**

>4 $\mu$ (c), >6 $\mu$ (c), >14 $\mu$ (c), >21 $\mu$ (c), >25 $\mu$ (c), >30 $\mu$ (c) counts per ml

**Secondary Diagnostic Output:**

% Volume Distribution, via graphical display on handset and printout

**International codes:**

ISO 7-22 in accordance with ISO 4406-1999

**Data entry:**

32 character two line dot matrix LCD. Full alpha numeric entry

facility on keypad

**Data retrieval:**

Memory access gives test search facility

**Calibration:**

In accordance with Parker Calibration Procedure CM20-N, which complies to ISO11171:1999, Clause 6 (Omitting Annex F)

**Re-calibration:**

Every 12 months by a dedicated Parker Service Centre (Consult

Parker)

**Max. working pressure:**

420 bar

**Operating Temperature:**

+5°C to +80°C

**Memory store:**

300 test capacity

**Computer compatibility:**

Interface via RS 232 connection @ 9600 baud rate (USB serial cable to RS232 option available)

**Laboratory sampling:**

Oil delivery unit (ODU) - test portion sampling device

**Portability:**

Only 8 kg. ACM20 has its own battery pack and carry case with wheels

**Power requirement:**

12vDC input, 6 x 'D' Cell or rechargeable batteries

**Printer facility:**

Integral 16 column printer for hard copy data

**Certification:**

Complies with all relevant EC declarations of conformity

### DEFSTAN 9191 Jet A-1 Fuel Specification, Adopts Energy Institute Test Method IP 564

Development work carried out by the CMC engineers, in conjunction with ExxonMobil Aviation, highlighted the need for an alternative test method to determine the levels of dispersed contamination in Jet fuel.

5 years of field testing and development of the already established and successful LCM20 Hydraulic Laser Particle Counter saw the introduction of the Parker ACM20 with enhanced software providing the user with a better understanding of the contamination present in a sample.

As the benchmark particle counter for use in measuring the levels of contamination in fuels, the ACM20, as per the UK's Energy Institute Test Method IP564, has now been included in the DEFSTAN 9191 Jet Fuel Specification as a report only test alongside the current Gravimetric test method (IP423 or ASTM D5452) and Clear & Bright Visual test method (IP216 or ASTM D2276).





## Specification

### Construction:

Case-Lexan structural foam and ABS  
Hand-held display - ABS  
Keypad fluorosilicone rubber

### Mechanical Components:

Brass, plated steel, stainless steel and aluminium

### Seals:

Fluorocarbon

### Hoses:

Nylon (Kevlar braided microbore). St. steel armoured ends

### Flow Rate:

25 - 50ml/min (dictated by ODU)

### Fluid Compatibility:

Hydrocarbon Fuel, Mineral Oil. For other fluids consult Parker

### Fuse:

1.25 amp fast blow fuse included for overload protection (spare supplied)

### ACM20 Technology:

Patented flow cell, light obscuration

### Repeatability/Accuracy:

As per or better than ISO 11171

### Coincidence:

40,000 particles per ml

### Viscosity Range:

1 -100 centistokes

### ACM20 Weight:

8 kg

### Monitor Carrying Case:

Astra Board case

### Carrying Case Weight:

5 kg

## Applications

The Parker ACM20 Portable Particle Counter has been developed from existing technology for monitoring contamination in AvTur and other Hydrocarbon fuels, in accordance with the Energy Institute (EI) Method IP 564.

In addition, the ACM can also be used to monitor various fuels from existing sampling points in locations from refineries, pipelines, distribution terminals, airport fuel supply systems all the way through to the point of uplift into aircraft\*.

\* Hot works permit required for online sampling (ATEX Zone II unit available).

### • Fuel Testing Laboratories – DefStan 9191

In order to better understand dispersed contamination in jet fuel, particle counting is now included alongside existing laboratory techniques

### • Bottle Sampling - Energy Institute (EI) - IP 564

Laboratory determination of the level of dispersed contamination in aviation kerosine using an Automatic Particle Counter (APC)

### • Replace Clear & Bright and Gravimetric

With the introduction of the ACM20, all subjectivity surrounding Clear & Bright and Gravimetric methods can be removed

### • Also for use on petroleum based hydraulic applications (Skydrol compatible available)

Suitable for use with mineral oil and petroleum based fluid as per standard hydraulic particle counter, reporting fluid cleanliness to ISO 4406:1999

# ACM20 Lab Unit

## DEF STAN 91-91 Issue 6

Defence Standard 91-91 is the specification for aviation turbine fuel, which the United Kingdom Civil Aviation Authority (CAA) has agreed is under the technical authority of the Director of the Defence Fuels Group.

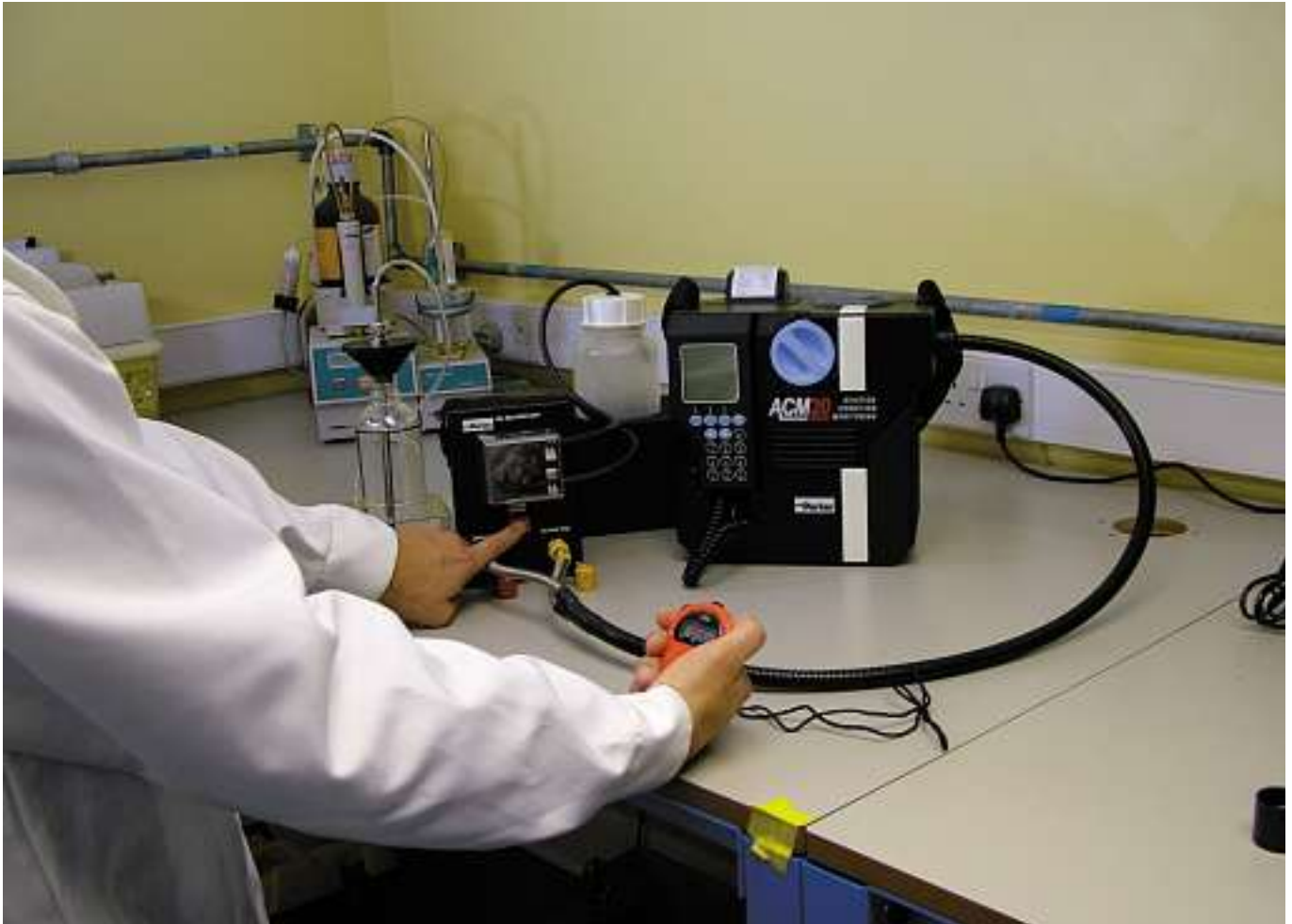

## IP 564

Laboratory determination of the level of dispersed contamination in aviation kerosene using an Automatic Particle Counter (APC).

This standard describes a method for determining the level of dispersed contamination in aviation kerosene fuels, specifically dirt particles and water droplets in the range from  $>4\mu(c)$  to  $>30\mu(c)$ . This method relates specifically to Aviation fuels but the equipment can be used on all fuels, petroleum and mineral based fluids.

# ACM20 Lab Unit

## IP 564 Procedure

### 1 Apparatus:

The apparatus shall be set up in accordance with manufacturers' operating instructions



### 2 Test Portion Preparation:

Decant a minimum of 450ml of the field sample into a clean test portion container



- 3 Prior to starting a test, tumble the test portion end over end for 60 seconds to ensure any settled particles are redistributed



- 4 Flush the equipment with the new test sample for 60 seconds prior to starting the test



- 5 Following the flush, start a test by turning the blue valve in the direction indicated Repeat a further 3 times

### Note:

The implementation date for IP 564 test method "Determination of the level of cleanliness of aviation turbine fuel - laboratory automatic particle counter" will be June 2009. It is the specification authorities intention to replace current test methods with particle counting at the earliest opportunity

# ACM20 Family

## Field Monitoring - ACM202022

For use in non-hazardous areas, the ACM2022 is designed for online sampling of hydrocarbon fuels and hydraulic systems, utilising existing "quick connect" sampling points such as the Millipore Adaptor



## Field Monitoring - ACM202032 (Z2)

The ACM202032 (Z2) is the worlds only ATEX approved portable particle counter for sampling directly from the process line in hazardous areas

- Assembled in an approved and certified stainless steel enclosure to comply with ATEX Directive 94/9/EC and EN50 021 requirements
- Certified to CE Ex 11 3 G Ex nR/nl 11C T6
- "A" Class product defined for the Aviation market
- ATEX approved handset and keypad



## Ordering Information

Standard products table - ACM20

Product number	Description
ACM202022UK	Particle counter UK*
ACM202022US	Particle counter US*
ACM202022EUR	Particle counter Euro*
ACM202024UK	Particle counter with lab kit UK (DefStan 9191)
ACM202024US	Particle counter with lab kit US (DefStan 9191)
<b>ACM202024EUR</b>	Particle counter with lab kit Euro (DefStan 9191)
B84794	1m process cable assembly
B84816	Parsmart downloader software
P843855	Carry case
B84746	Bottle assembly
B84745	Throttle kit
B84645	Millipore adaptor assy
B84609	Re-chargeable battery pack
B84817	UK power supply
B84830	US power supply
B84831	Euro power supply
B84832	Laboratory kit

Note 1: Part numbers featured with bold highlighted codes will ensure a 'standard' product selection.

Note 2: Alternate displayed part number selection will require you to contact Parker Filtration for availability.

\* Hot works permit required for online sampling.



# ACM20 Z2



## ATEX Approved Portable Particle Counter

# ACM20 Z2

### Features & Benefits

**Test Time:**

2 minutes.

**Repeat Test Time:**

Every 2 minutes (Manual testing) Every 6 minutes (Automatic).

**Principle of Operation:**

Optical scanning analysis and measurement of actual particles and inference to water presence.

**Primary Output:**

>4 $\mu$ (c), >6 $\mu$ (c), >14 $\mu$ (c), >21 $\mu$ (c), >25 $\mu$ (c), >30 $\mu$ (c) counts per ml.

**Secondary Diagnostic Output:**

% Volume Distribution, via graphical display on handset.

**International codes:**

ISO 7-22 in accordance with ISO 4406-1999

**Data entry:**

32 character two line dot matrix LCD. Full alpha numeric entry facility on keypad.

**Data retrieval:**

Memory access gives test search facility.

**Calibration:**

In accordance with Parker Calibration Procedure CM20-N, which complies to ISO11171:1999, Clause 6 (Omitting Annex F).

**Re-calibration:**

Every 12 months by a dedicated Parker Service Centre (Consult Parker).

**Max. working pressure:**

420 bar.

**Operating Temperature:**

+5°C to +80°C

**Memory store:**

300 test (scrolling memory) capacity.

**Computer compatibility:**

Interface via RS 232 connection @ 9600 baud rate.

**Portability:**

15 kg. ACM20 has its own battery pack and carry case with wheels.

**Power requirement:**

Rechargeable battery powered or via the 12vDC input.

**System connection:**

Via Millipore adaptor with flow restriction through supplied needle valve.

**Certification:**

Complies with all relevant EC declarations of conformity

- Assembled in an approved and certified stainless steel enclosure to comply with ATEX Directive 94/9/EC and EN50 021 requirements.
- Can be used in explosive and hazardous areas, including Offshore and Mining.
- Certified to CE Ex II 3 G Eex nA/nL IIB T \* (\*as tested)
- "A" Class product defined for the Aviation market.
- ATEX approved Handset and keypad.
- Suitable for use with mineral oil and petroleum based fluid as per LCM20 particle counter.





## Specification

Construction:

**Unit:** stainless steel

**Carrying case:** ABS

**Hand-held display:** ABS

**Keypad:** polyester membrane

Mechanical components:

Brass, plated steel, stainless steel and aluminium

**Seals:** Viton

**Hoses:** Nylon (Kevlar braided microbore)

**Fluid compatibility:**

All fuels. For other fluids consult Parker

Internal rechargeable battery:

Note: ONLY to be charged outside of the hazardous area, with the unit switched off

**Fuse:**

1.25A fast blow fuse included for overload protection

Return to Parker Hannifin if fuse is blown

**ACM20.2032 technology:**

Unique optical scanning system

**Repeatability/Accuracy:**

Better than 5% (typical)

## Using ACM20 Z2

ACM20Z2 is designed to be used to monitor various fuels from existing sampling points in hazardous locations from refineries, pipelines, distribution terminals, airport fuel supply systems all the way through to the point of uplift into aircraft. With Zone 2 classification, the ACM20Z2 is the worlds only ATEX approved particle counter.



## Applications in Fuels

- **Oil Refinery**
  - To count and verify the levels of dispersed contamination in accordance with specification limits.
- **Distribution Terminals/Hubs**
  - For use on receipt and outbound supply. Also to provide filtration performance, tank cleanliness and product quality checks.
- **Storage**
  - Settling times can be reduced by monitoring with the ACM by ensuring that levels of dispersed contamination are below acceptable levels.
- **Airport Fuel Farm**
  - Monitoring of the fuels into storage, through the fuel farm, hydrant system and uplift into wing.
- **Pipeline Commissioning**
  - Fast real time monitoring of pipelines following pigging and cleaning processes.
- **Oil and Gas Platforms**
  - Used to monitor the filtration performance, system cleanliness and quality of delivered product.



# ACM20 Z2

## Applications in hydraulics

### Solutions in the offshore industry.

In addition, the ACM20 Z2 can be used in many hydraulic system applications as detailed below.

In many industries, worker awareness needs to be maintained at a high level to ensure the safety of their operation. This is particularly relevant to offshore oil-drilling and gas-drilling crews, given the interactive and hazardous nature of their work. The Zone 2 ACM20 portable particle analyser is a tried and tested technology designed, proven and approved as a fluid contamination monitor that crews are using and trusting in such hazardous and demanding environments.

- Certified to CE Ex II 3 G EexnA/nL IIB T\* (\*as tested).
- Can be used in explosive and hazardous areas, including Offshore and Mining.
- Primary Output. Six cumulative particle size channels ranging from  $>4\mu\text{m}(c)$  to  $>30\mu\text{m}(c)$  and numbers per ml in accordance with ISO4406-1999.



### ACM20Z2 – operational in oil refineries and fuel fields.

Already operational in oil refineries and designed to be used inside commercial airfield fuel locations and at the point of upload of fuel into the aircraft, ACM20Z2 has an impressive success record in this approvals sensitive area of operation.

With a number of safety features designed in as operational standards, the ACM20Z2 can be taken to the point of use, connected in moments and reporting in little more than 2 minutes to ISO approved standards.

- Assembled in an approved and certified stainless steel enclosure to comply with ATEX Directive 94/9/EC and EN50 021 requirements.
- 'A' Class product defined for the aviation market.
- Designed for on-line operation, connecting to the process line via existing Millipore™ fittings, already in use for other industry equipment.

### Applications in other hazardous environments.

- Railroad equipment manufacturer - Warranty protection.
- Power generation stations - Preventative maintenance.
- Mobile equipment - Roll-off cleanliness testing.
- Mining operations - Service tool.
- Steel mills - Preventative maintenance.



## Online Commission Kit

- a – ACM20 Zone 2 Particle Counter
- b – Battery Charger
- c – Process Cable
- d – User Manual
- e – Downloader Software
- f – Throttle Kit
- g – Millipore Adaptor Assembly
- h – Aluminium Case
- i – Bottle Assembly



## Installation Details

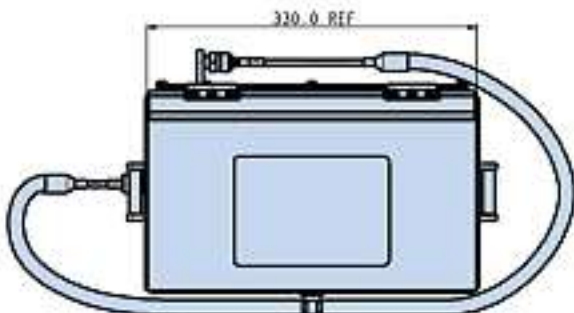
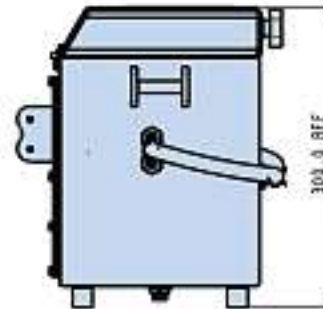
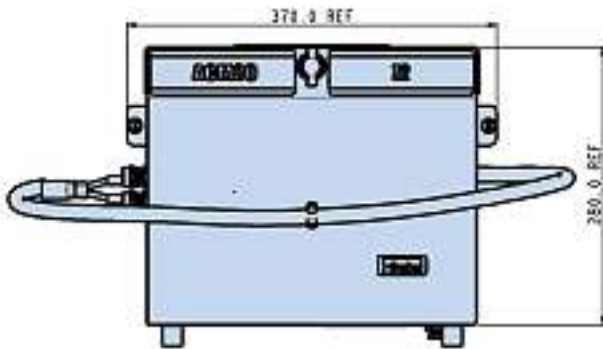

## ATEX Approved Portable Particle Counter

# ACM20 Z2

### Alternative Fuel Monitoring



In addition to the Z2 Parker also have the ACM20 laboratory Particle Counter which has been designed in accordance with the Energy Institute (EI) Method IP PM DK.

The ACM20 with additional laboratory kit is proposed as an alternative method for use within DefStan 9191 – the standard for aviation turbine fuel, which the United Kingdom Civil Aviation Authority (CAA) has agreed is under the technical authority of the Director Defence Fuels Group.

The ACM can also be used to monitor various fuels from existing sampling points in the same way as the Z2\*.

\*Hot works permit required for online sampling.

#### Laboratory Kit

The Oil Delivery Unit (ODU) laboratory kit is a peristaltic pump unit that allows fuel to be pumped through the ACM20 for testing purposes offline.

#### Specification

**Height:** 150mm wide x 150mm deep x 170mm

**Weight:** 1.7 kg

#### Power Requirement:

Can be run from the 12-volt ACM20 power supply or from another suitable supply via the connecting lead supplied.

**Fuse:** 0.5 amp fast blow fuse included for overload protection.

**Minimum Flow Rate:** 15ml/min.



### Average Particle Counts in AV System

The table below gives estimated counts found in a typical aviation fuel distribution system, and is given as guidance, in which APR/ EI filtration equipment is installed.

Receipt into Microfilter  
Expect 2,500 counts per ml or cleaner @ 4µ(c)



Receipt into Microfilter		ISO Code - 4406 1999
	High Count	High Count Code
>4µ(c)	2,500	18
>6µ(c)	350	15
>14µ(c)	10	10

Receipt into FWS (After MF)  
Expect 500 counts per ml or cleaner @ 4µ(c)



Receipt into FWS (After MF)		ISO Code - 4406 1999
	High Count	High Count Code
>4µ(c)	500	16
>6µ(c)	50	13
>14µ(c)	5	9

Receipt into Storage (After FWS/MF)  
Expect 100 counts per ml or cleaner @ 4µ(c)



Receipt into Storage (After FWS/MF)		ISO Code - 4406 1999
	High Count	High Count Code
>4µ(c)	100	14
>6µ(c)	10	10
>14µ(c)	1	7

FWS out of storage  
Expect 500 counts per ml or cleaner @ 4µ(c)



FWS Out of Storage		ISO Code - 4406 1999
	High Count	High Count Code
>4µ(c)	500	16
>6µ(c)	50	13
>14µ(c)	5	9

After FWS into Hydrant  
Expect 100 counts per ml or cleaner @ 4µ(c)



After FWS Into Hydrant		ISO Code - 4406 1999
	High Count	High Count Code
>4µ(c)	100	14
>6µ(c)	10	10
>14µ(c)	1	7

After Monitor Into Plane  
Expect 100 counts per ml or cleaner @ 4µ(c)



After Monitor Into Plane		ISO Code - 4406 1999
	High Count	High Count Code
>4µ(c)	100	14
>6µ(c)	10	10
>14µ(c)	1	7

Note: Figures will vary from location to location.

## Ordering Information

Standard products table - ACM20 Z2

Product number	Description
ACM202032UK	Particle counter with online kit & UK power supply
ACM202032US	Particle counter with online kit & US power supply
<b>ACM202032EUR</b>	Particle counter with online kit & Euro power supply
ACM202034UK	Particle counter with online & lab kit + UK power supply
ACM202034US	Particle counter with online & lab kit + US power supply
ACM202034EUR	Particle counter with online & lab kit + Euro power supply
B84647	UK battery charger
B84652	US battery charger
B84653	Euro battery charger
B84650	2m process cable assembly
B84816	Parsmart downloader software
P843066	Carry case
B84746	Bottle assembly
B84745	Throttle kit
B84645	Millipore adaptor assy

Important Information



**WARNING – USER RESPONSIBILITY**

**FAILURE OR IMPROPER SELECTION OR IMPROPER USE OF THE PRODUCTS DESCRIBED HEREIN OR RELATED ITEMS CAN CAUSE DEATH, PERSONAL INJURY AND PROPERTY DAMAGE.**

- This document and other information from Parker Hannifin Corporation, its subsidiaries and authorized distributors provide product or system options for further investigation by users having technical expertise.
- The user, through its own analysis and testing, is solely responsible for making the final selection of the system and components and assuring that all performance, endurance, maintenance, safety and warning requirements of the application are met.

The user must analyze all aspects of the application, follow applicable industry standards, and follow the information concerning the product in the current product catalogue and in any other materials provided from Parker or its subsidiaries or authorized distributors.

- To the extent that Parker or its subsidiaries or authorized distributors provide component or system options based upon data or specifications provided by the user, the user is responsible for determining that such data and specifications are suitable and sufficient for all applications and reasonably foreseeable uses of the components or systems.

**Sales conditions**

The items described in this document are available for sale by Parker Hannifin Corporation, its subsidiaries or its authorized distributors. Any sale contract entered into by Parker will be governed by the provisions stated in Parker’s standard terms and conditions of sale (copy available upon request).

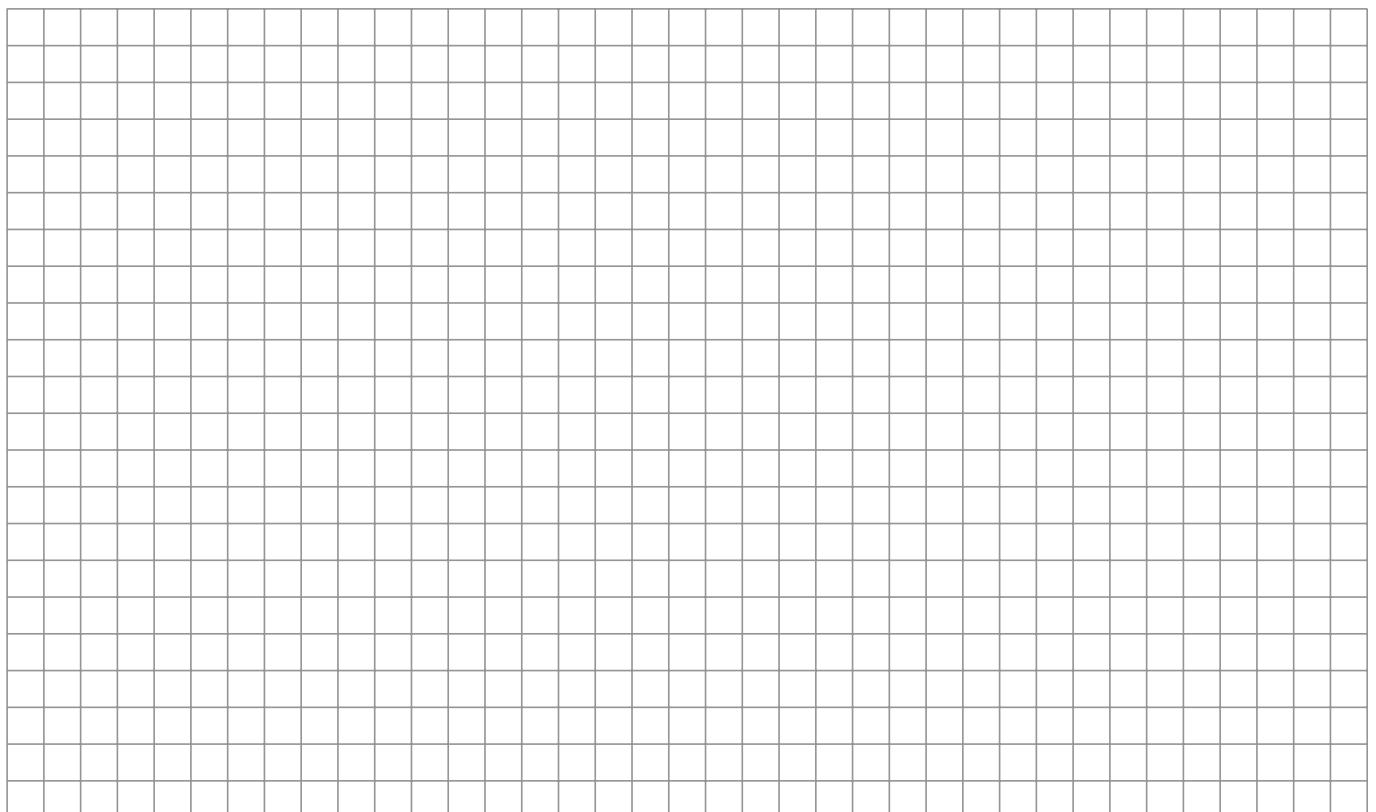

# Parker's Motion & Control Technologies

At Parker, we're guided by a relentless drive to help our customers become more productive and achieve higher levels of profitability by engineering the best systems for their requirements. It means looking at customer applications from many angles to find new ways to create value. Whatever the motion or control technology need, Parker has the experience, breadth of product and global reach to consistently deliver. No company knows more about motion and control technology than Parker.



## AEROSPACE

### Key Markets

- Aircraft engines
- Business & general aviation
- Commercial transports
- Land-based weapons systems
- Military aircraft
- Missiles & launch vehicles
- Regional transports
- Unmanned aerial vehicles

### Key Products

- Flight control systems & components
- Fluid conveyance systems
- Fluid metering delivery & atomization devices
- Fuel systems & components
- Hydraulic systems & components
- Inert nitrogen generating systems
- Pneumatic systems & components
- Wheels & brakes



## CLIMATE CONTROL

### Key Markets

- Agriculture
- Air conditioning
- Food, beverage & dairy
- Life sciences & medical
- Precision cooling
- Processing
- Transportation

### Key Products

- CO<sub>2</sub> controls
- Electronic controllers
- Filter driers
- Hand shut-off valves
- Hose & fittings
- Pressure regulating valves
- Refrigerant distributors
- Safety relief valves
- Solenoid valves
- Thermostatic expansion valves



## ELECTROMECHANICAL

### Key Markets

- Aerospace
- Factory automation
- Life science & medical
- Machine tools
- Packaging machinery
- Paper machinery
- Plastics machinery & converting
- Primary metals
- Semiconductor & electronics
- Textile
- Wire & cable

### Key Products

- AC/DC drives & systems
- Electric actuators, gantry robots & slides
- Electrohydraulic actuation systems
- Electromechanical actuation systems
- Human machine interface
- Linear motors
- Stepper motors, servo motors, drives & controls
- Structural extrusions



## FILTRATION

### Key Markets

- Food & beverage
- Industrial machinery
- Life sciences
- Marine
- Mobile equipment
- Oil & gas
- Power generation
- Process
- Transportation

### Key Products

- Analytical gas generators
- Compressed air & gas filters
- Condition monitoring
- Engine air, fuel & oil filtration & systems
- Hydraulic, lubrication & coolant filters
- Process, chemical, water & microfiltration filters
- Nitrogen, hydrogen & zero air generators



## FLUID & GAS HANDLING

### Key Markets

- Aerospace
- Agriculture
- Bulk chemical handling
- Construction machinery
- Food & beverage
- Fuel & gas delivery
- Industrial machinery
- Mobile
- Oil & gas
- Transportation
- Welding

### Key Products

- Brass fittings & valves
- Diagnostic equipment
- Fluid conveyance systems
- Industrial hose
- PTFE & PFA hose, tubing & plastic fittings
- Rubber & thermoplastic hose & couplings
- Tube fittings & adapters
- Quick disconnects



## HYDRAULICS

### Key Markets

- Aerospace
- Aerial lift
- Agriculture
- Construction machinery
- Forestry
- Industrial machinery
- Mining
- Oil & gas
- Power generation & energy
- Truck hydraulics

### Key Products

- Diagnostic equipment
- Hydraulic cylinders & accumulators
- Hydraulic motors & pumps
- Hydraulic systems
- Hydraulic valves & controls
- Power take-offs
- Rubber & thermoplastic hose & couplings
- Tube fittings & adapters
- Quick disconnects



## PNEUMATICS

### Key Markets

- Aerospace
- Conveyor & material handling
- Factory automation
- Life science & medical
- Machine tools
- Packaging machinery
- Transportation & automotive

### Key Products

- Air preparation
- Brass fittings & valves
- Manifolds
- Pneumatic accessories
- Pneumatic actuators & grippers
- Pneumatic valves & controls
- Quick disconnects
- Rotary actuators
- Rubber & thermoplastic hose & couplings
- Structural extrusions
- Thermoplastic tubing & fittings
- Vacuum generators, cups & sensors



## PROCESS CONTROL

### Key Markets

- Chemical & refining
- Food, beverage & dairy
- Medical & dental
- Microelectronics
- Oil & gas
- Power generation

### Key Products

- Analytical sample conditioning products & systems
- Fluoropolymer chemical delivery fittings, valves & pumps
- High purity gas delivery fittings, valves & regulators
- Instrumentation fittings, valves & regulators
- Medium pressure fittings & valves
- Process control manifolds



## SEALING & SHIELDING

### Key Markets

- Aerospace
- Chemical processing
- Consumer
- Energy, oil & gas
- Fluid power
- General industrial
- Information technology
- Life sciences
- Military
- Semiconductor
- Telecommunications
- Transportation

### Key Products

- Dynamic seals
- Elastomeric o-rings
- EMI shielding
- Extruded & precision-cut, fabricated elastomeric seals
- Homogeneous & inserted elastomeric shapes
- High temperature metal seals
- Metal & plastic retained composite seals
- Thermal management



ENGINEERING YOUR SUCCESS.

# Parker Worldwide

**AE – UAE, Dubai**  
Tel: +971 4 8127100  
parker.me@parker.com

**AR – Argentina, Buenos Aires**  
Tel: +54 3327 44 4129

**AT – Austria, Wiener Neustadt**  
Tel: +43 (0)2622 23501-0  
parker.austria@parker.com

**AT – Eastern Europe, Wiener Neustadt**  
Tel: +43 (0)2622 23501 970  
parker.easteurope@parker.com

**AU – Australia, Castle Hill**  
Tel: +61 (0)2-9634 7777

**AZ – Azerbaijan, Baku**  
Tel: +994 50 2233 458  
parker.azerbaijan@parker.com

**BE/LU – Belgium, Nivelles**  
Tel: +32 (0)67 280 900  
parker.belgium@parker.com

**BR – Brazil, Cachoeirinha RS**  
Tel: +55 51 3470 9144

**BY – Belarus, Minsk**  
Tel: +375 17 209 9399  
parker.belarus@parker.com

**CA – Canada, Milton, Ontario**  
Tel: +1 905 693 3000

**CH – Switzerland, Etoy**  
Tel: +41 (0) 21 821 02 30  
parker.switzerland@parker.com

**CN – China, Shanghai**  
Tel: +86 21 5031 2525

**CZ – Czech Republic, Klecany**  
Tel: +420 284 083 111  
parker.czechrepublic@parker.com

**DE – Germany, Kaarst**  
Tel: +49 (0)2131 4016 0  
parker.germany@parker.com

**DK – Denmark, Ballerup**  
Tel: +45 43 56 04 00  
parker.denmark@parker.com

**ES – Spain, Madrid**  
Tel: +34 902 33 00 01  
parker.spain@parker.com

**FI – Finland, Vantaa**  
Tel: +358 (0)20 753 2500  
parker.finland@parker.com

**FR – France, Contamine s/Arve**  
Tel: +33 (0)4 50 25 80 25  
parker.france@parker.com

**GR – Greece, Athens**  
Tel: +30 210 933 6450  
parker.greece@parker.com

**HK – Hong Kong**  
Tel: +852 2428 8008

**HU – Hungary, Budapest**  
Tel: +36 1 220 4155  
parker.hungary@parker.com

**IE – Ireland, Dublin**  
Tel: +353 (0)1 466 6370  
parker.ireland@parker.com

**IN – India, Mumbai**  
Tel: +91 22 6513 7081-85

**IT – Italy, Corsico (MI)**  
Tel: +39 02 45 19 21  
parker.italy@parker.com

**JP – Japan, Tokyo**  
Tel: +(81) 3 6408 3901

**KR – South Korea, Seoul**  
Tel: +82 2 559 0400

**KZ – Kazakhstan, Almaty**  
Tel: +7 7272 505 800  
parker.easteurope@parker.com

**LV – Latvia, Riga**  
Tel: +371 6 745 2601  
parker.latvia@parker.com

**MX – Mexico, Apodaca**  
Tel: +52 81 8156 6000

**MY – Malaysia, Subang Jaya**  
Tel: +60 3 5638 1476

**NL – The Netherlands, Oldenzaal**  
Tel: +31 (0)541 585 000  
parker.nl@parker.com

**NO – Norway, Ski**  
Tel: +47 64 91 10 00  
parker.norway@parker.com

**NZ – New Zealand, Mt Wellington**  
Tel: +64 9 574 1744

**PL – Poland, Warsaw**  
Tel: +48 (0)22 573 24 00  
parker.poland@parker.com

**PT – Portugal, Leca da Palmeira**  
Tel: +351 22 999 7360  
parker.portugal@parker.com

**RO – Romania, Bucharest**  
Tel: +40 21 252 1382  
parker.romania@parker.com

**RU – Russia, Moscow**  
Tel: +7 495 645-2156  
parker.russia@parker.com

**SE – Sweden, Spånga**  
Tel: +46 (0)8 59 79 50 00  
parker.sweden@parker.com

**SG – Singapore**  
Tel: +65 6887 6300

**SK – Slovakia, Banská Bystrica**  
Tel: +421 484 162 252  
parker.slovakia@parker.com

**SL – Slovenia, Novo Mesto**  
Tel: +386 7 337 6650  
parker.slovenia@parker.com

**TH – Thailand, Bangkok**  
Tel: +662 717 8140

**TR – Turkey, Istanbul**  
Tel: +90 216 4997081  
parker.turkey@parker.com

**TW – Taiwan, Taipei**  
Tel: +886 2 2298 8987

**UA – Ukraine, Kiev**  
Tel: +380 44 494 2731  
parker.ukraine@parker.com

**UK – United Kingdom, Warwick**  
Tel: +44 (0)1926 317 878  
parker.uk@parker.com

**US – USA, Cleveland**  
Tel: +1 216 896 3000

**VE – Venezuela, Caracas**  
Tel: +58 212 238 5422

**ZA – South Africa, Kempton Park**  
Tel: +27 (0)11 961 0700  
parker.southafrica@parker.com

European Product Information Centre  
Free phone: 00 800 27 27 5374  
(from AT, BE, CH, CZ, DE, EE, ES, FI, FR, IE, IT, PT, SE, SK, UK)

**Parker Hannifin Ltd.**  
**Hydraulic Filter Division Europe**  
**Condition Monitoring Centre**  
Tel.: +44 (0) 1842 763299  
Email: [conmoninfo@parker.com](mailto:conmoninfo@parker.com)  
[www.parker.com/hfde](http://www.parker.com/hfde)

