

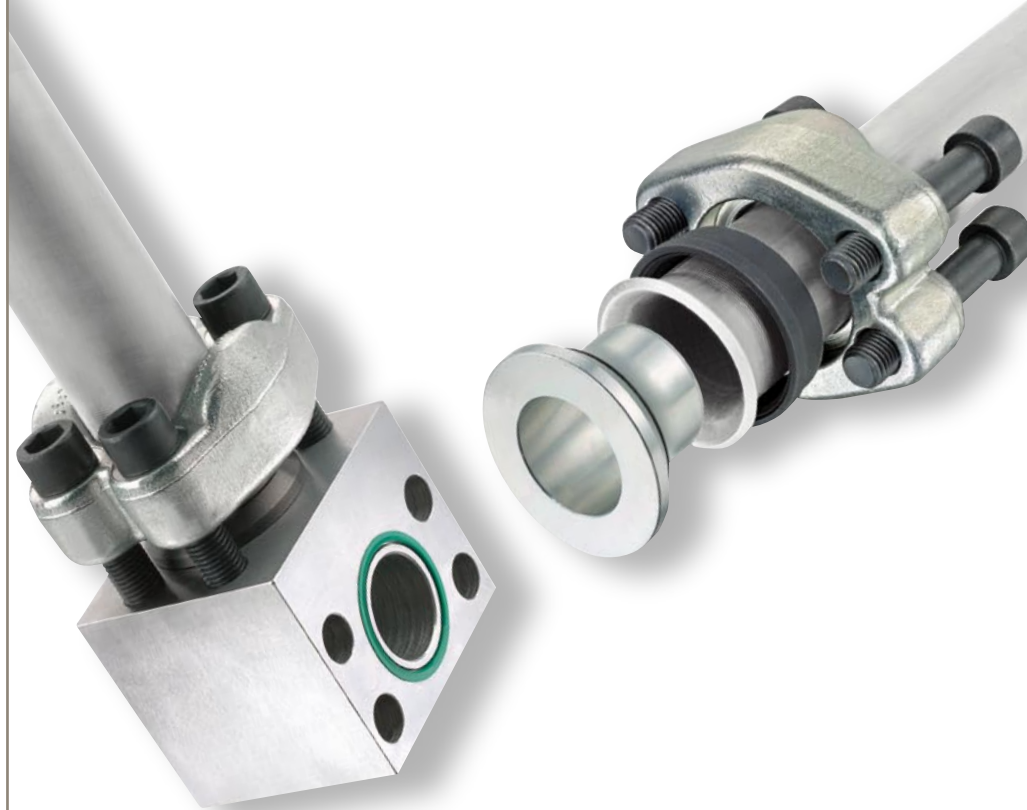

aerospace
climate control
electromechanical
filtration
fluid & gas handling
hydraulics
pneumatics
process control
sealing & shielding



HPF – Parker High Performance Flange System

the tear out-proof flange system for high pressure applications



ENGINEERING YOUR SUCCESS.

Table of contents

Introduction..... Page 2

General information..... 5

Technical data..... 9

Installation 15

Machine, tooling and equipment..... 21

Ordering information/Nomenclature 27

HPF – SAE 6000/ISO 6162-2 31

HPF – Square Flange/ISO 6164 45

Tube clamps..... 59

Tubes 93



For your safety!

Under certain circumstances, tube fittings can be subjected to extreme loadings such as vibration and uncontrolled pressure peaks.

Only by using genuine Parker components and following Parker assembly instructions can you be assured of the reliability and safety of the products and their conformity to the applicable standards.

Failure to follow this rule can adversely affect the functional safety and reliability of products, cause personal injury, property damage, and result in loss of your guarantee rights.

Subject to alteration

© Copyright 2008, Parker Hannifin Corporation. All Rights Reserved.



Tube Fittings Division Europe

The Tube Fittings Authority:

Performance Plus

Since 1929, Parker Hannifin Corporation has served the market with dependable fluid power technology. Today, Parker offers more than 100,000 quality products for a broad range of industries and applications. No other manufacturer presents a product line as broad as Parker's, nor an expertise as far-reaching in hydraulic and pneumatic systems and components. Much of that expertise originates with Parker's precision-made tube fittings, which were among the first products manufactured by the company. As such, they reflect Parker's ongoing commitment to excellence.

With more than seventy years of experience in product design, engineering, applications technology and manufacturing, the Tube Fittings Division Europe holds a leadership position few other manufacturers can claim. This leadership is further heightened and enhanced by the sharing of technology only possible in Parker's corporate family.

Topflight Experience

Parker has used the background data and knowledge gained from important industrial, mobile, offshore and other applications to create the broadest and best performing line of standard tube fittings in the world.

Why is Parker a topflight manufacturer of fittings?

There are many reasons, but at the heart is the design and manufacturing excellence that goes into every Parker product.

Worldwide standardising activities

The Parker Fluid Connectors Group supports the national and international standardising activities. Experienced engineers from certain countries and Divisions give their input to national committees like SAE, BS, and DIN committees in cooperation with the users of the products. As a result, many ISO Fluid Connector standards have been published. These ISO standards are the platform for the international trading, interchangeability and availability that is necessary for all globally operating companies using fluid power technology.

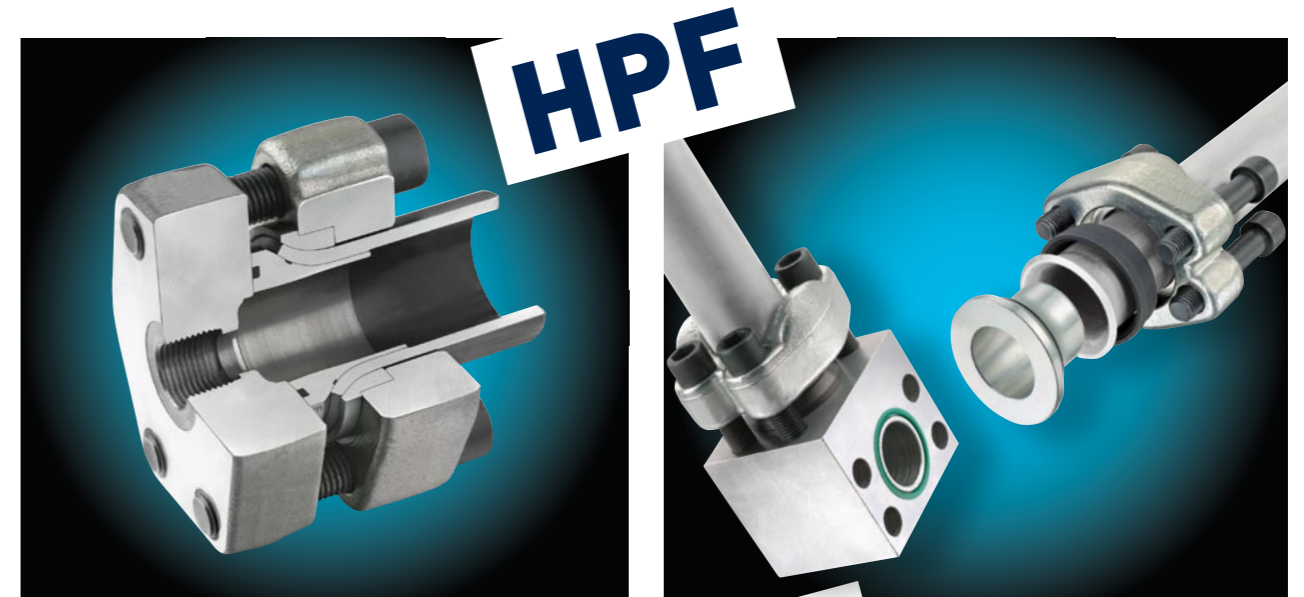



General information

HPF – The technology

Parker's Mechanical Flange System for the toughest requirements

Parker's HPF system was specially designed and set up to meet the freedom from leakage, performance and high working pressure requirements of mobile hydraulics and the industrial equipment, such as injection moulding.

The System

The HPF system is appropriate for the tube sizes normally used in these industries, for tube diameters from 25 to 88 mm and for wall thicknesses up to 14 mm. The system is designed for flange patterns to ISO 6162-2 (code 62), to ISO 6164, and also to ISO 6162-1 (code 61) if necessary.

Learning from Nature

The best solutions to complex design problems are often found in nature. The flaring of a tube is similar to the shape of a branch where it joins the trunk of a tree. The tube is flared by means of axial hydraulic pressure either to 37° or 10° in accordance with the systems nowadays found in the market place. The HPF system combines both these possibilities. The formation zone of the tube corresponds to a parabola running from 10° to 37°. An additional safety feature against strong system vibration arises because of this flat formation zone.

The HPF Connector – Strong Teamwork for the Toughest Demands

At the heart of the HPF connector is the locking. It is specially hardened and is manufactured with a special contour. This ring, which supports the tube assembly from the outside, provides the connector with additional tear out safety. An insert is introduced into the formed tube; it seals on the port side with a choice of either a special profile seal or an O-ring, and on the tube side with an O-ring. The insert does not have a toothed profile and therefore makes repeat assemblies possible without problems.

No Additional Assembly Tools Required

Unlike other mechanical flange systems, HPF does not require any hydraulic bolt drivers during assembly. So even in difficult conditions, the bolts can be simply tightened.

HPF Machine

A hydraulic axial press is required for tube forming. This is available as a complete WorkCentre with integrated tool compartments. It stands on transportation casters and can be easily moved by one person; it also has crane and lift truck points to provide maximum flexibility.

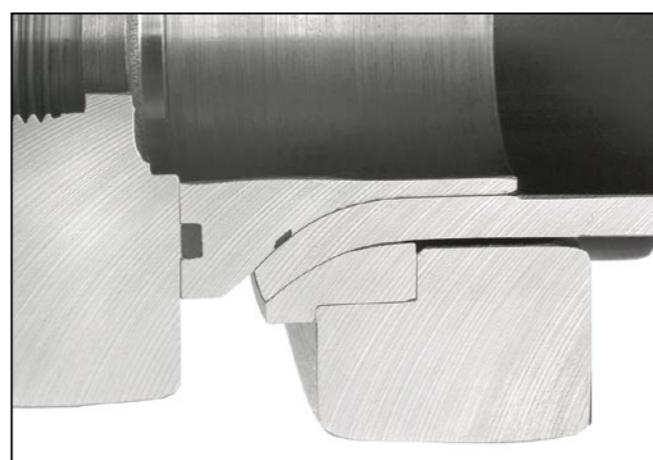
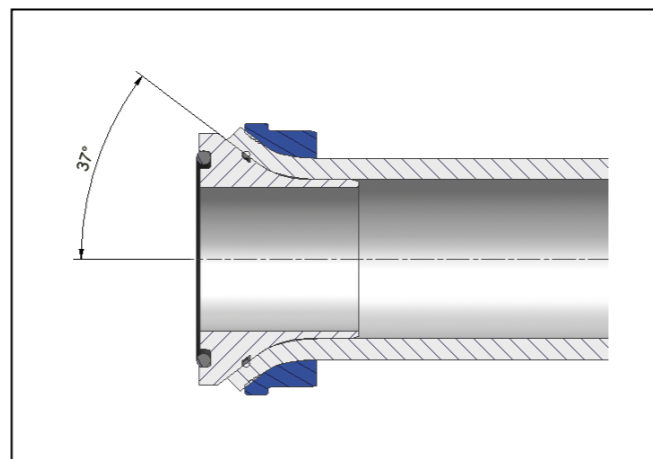

HPF – The technology

HPF Performance

The system is generally applicable for working pressures up to 420 bar. Force distribution on the components is ideal, as the diagram makes clear.

In contrast to conventional O-rings, the special profile seal is especially resistant to gap extrusion. A further significant advantage against other systems is the compactness of the HPF system. This refers to the minimum length from the port to the starting point of the tube bend, an important factor in designs having only limited access and space in which to assemble.

Flanges instead of Welding

Error free Assembly

Nowadays many tube connections are welded. But because even the best welders can make mistakes, every single welded seam has to be checked. This of course leads to enormous loss of time and corresponding costs. However, problems usually start already when trying to find qualified personnel. So Parker's HPF system offers several advantages compared to welded connections.

- The welding of galvanic zinc-plated tubes is always problematic - HPF can be used with zinc-plated tubes (No painting afterwards necessary).
- Welded points must be descaled and often stained (That can harm the environment!).
- The tube does not have to be cleaned after flanging as it does in welded connections.
- There are no noxious gases arising from the flanging process and there is no risk of explosion or fire.

Cr(VI)-free Corrosion Protection

It goes without saying that all the components have Cr(VI)-free surfaces.

Parker is very conscious of its responsibility to the environment and to human health and has therefore given up the employment of surfaces containing Cr(VI).

Parker the System Supplier

Parker products are always available world wide regardless of what is required. Parker considers itself a partner of all of its customers including activities such as development, design, execution and maintenance for customer-specific projects. This service also includes the holding of stocks for customers as well as looking after them on site. Naturally all of this leads to enormous cost reductions.

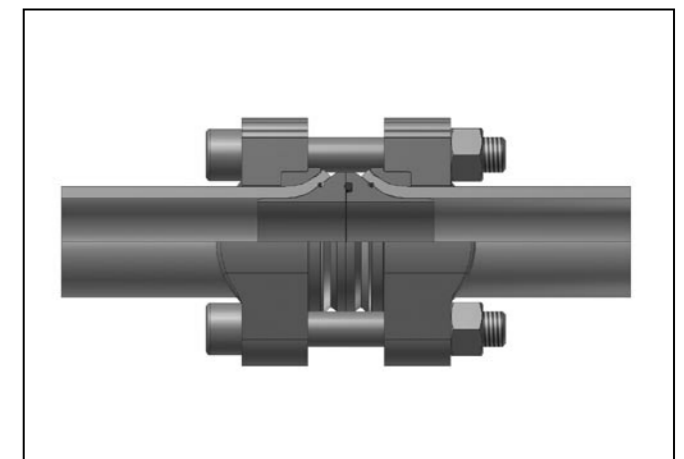
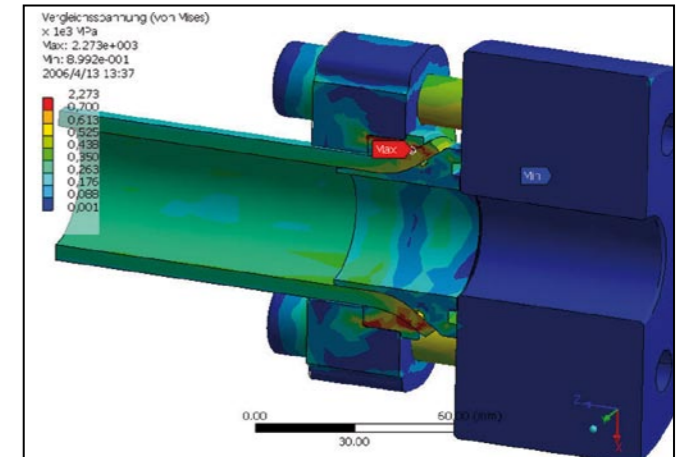

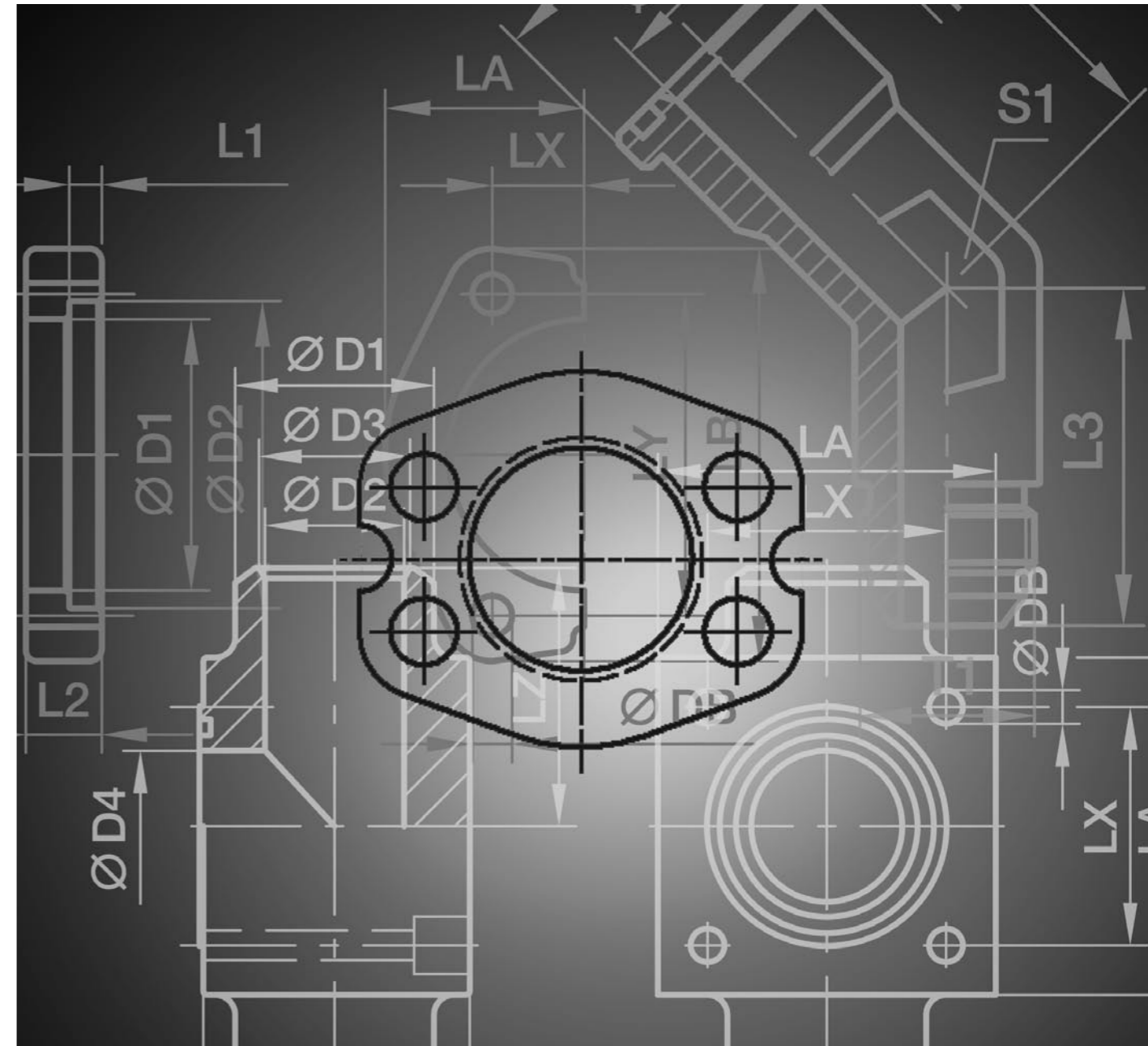

Technical data

Overview: Suitable tube sizes HPF

Table shows the nominal pressure PN with the use of tubes acc. to E 355 N (St. 52.4 NBK).
For details see page 93 – chapter tubes

100 bar	160 bar	250 bar	315 bar	400 bar	420 bar
25x3.0	25x3.0	25x3.0	25x3.0	---	---
25x4.0	25x4.0	25x4.0	25x4.0	25x4.0	25x4.0
30x4.0	30x4.0	30x4.0	30x4.0	---	---
30x5.0	30x5.0	30x5.0	30x5.0	30x5.0	30x5.0
35x5.0	35x5.0	35x5.0	35x5.0	---	---
38x4.0	38x4.0	38x4.0	---	---	---
38x5.0	38x5.0	38x5.0	38x5.0	---	---
38x6.0	38x6.0	38x6.0	38x6.0	38x6.0	38x6.0
42x5.0	42x5.0	42x5.0	42x5.0	---	---
50x3.0	50x3.0	---	---	---	---
50x5.0	50x5.0	50x5.0	---	---	---
50x6.0	50x6.0	50x6.0	50x6.0	---	---
50x8.0	50x8.0	50x8.0	50x8.0	50x8.0	50x8.0
60x8.0	60x8.0	60x8.0	60x8.0	---	---
65x8.0	65x8.0	65x8.0	65x8.0	---	---
66x8.5	66x8.5	66x8.5	66x8.5	---	---
75x12.5	75x12.5	75x12.5	75x12.5	75x12.5	---
80x3.0	---	---	---	---	---
80x8.0	80x8.0	80x8.0	---	---	---
80x10.0	80x10.0	80x10.0	80x10.0	---	---
88x14.0	88x14.0	88x14.0	88x14.0	---	---

The pressure rates are based on the calculated pressure of the corresponding tubes.
The pressure rates of the flange-components are designed with a safety factor of PN x 4.

Pressure reductions and temperatures

Required pressure reductions (dependent on the material) with reference to the catalogue pressures for higher temperatures. Both metal fitting material and elastomeric sealing compound have to be selected according to the temperature range of the system.

Material	Pressure reduction of permissible operating temperatures TB in °C															
	-60	-54	-40	-35	-25	+20	+50	+100	+120	+150	+175	+200	+250	+300	+400	
Steel + Steel tubes			0%								11%	19%		27%		
Stainless steel + Stainless steel tubes	0%						11%			20%		30%				
Sealing material NBR (e.g. Perbunan)																
Sealing material FKM																
Sealing material polyurethane (P5008)																

Perbunan = registered trademark of Bayer

Calculation example:
 Temperature = 200 °C
 Material = Stainless steel
 Pressure reduction = 20%
 Pressure reduction tubes = 21.5%
 PN tube 16x2.5/71. DIN2413 III = 362 bar

Formula:
 $PN_{\text{Connection } 200\text{ °C}} = \frac{400 \text{ bar}}{100\%} \times (100\% - 20\%) = 320 \text{ bar}$
 $PN_{\text{tube } 200\text{ °C}} = \frac{362 \text{ bar}}{100\%} \times (100\% - 21.5\%) = 284 \text{ bar}$

F37 seal

The F37 seal was developed especially for use with SAE flanges. Compared to a standard O-ring the special profile of the F37 seal is ideally adapted to higher pressures or unsuitable surface finish of the flanges. The particularly low compression set of the polyurethane compound ensures dimensional stability of the seal over a large temperature range. Its high extrusion resistance prevents gap extrusion even if the flanges “breathe“ under pressure. Due to

good abrasion resistance, less preparation is necessary on the surface finish of the sealing area of the flange. The frequently occurring “pumping“ phenomenon of O-rings is prevented by the shape of the F37 seal.

Application area
 Static sealing for SAE-Flanges
 Working pressure: ≤ 600 bar
 Working temperature: see table above

Materials
 The F37 seal is made of a polyurethane based Parker compound with a hardness of approx. 93 Shore A. In comparison with other polyurethane materials currently available on the market, it excels because of its increased heat resistance, improved performance against hydrolysis and low compression values.

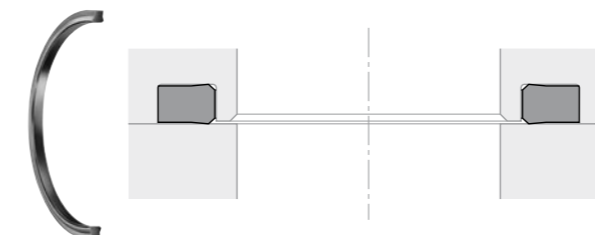

Flow characteristics

Hydraulic systems are in most cases only rated with a flow velocity defined on the basis of experience. The pressure losses in lines are not taken into account, or measured later on when testing the system. As the pressure losses increase proportionally greater than the flow resistance, it is important to achieve the best rating of the system, so that they are already taken into account when planning the tube connections. Calculation is not as difficult as it is often thought, and this chapter is intended to provide a guideline. Besides, it provides information on how excessive pressure losses can be avoided, because pressure losses result in losses in performance and excessive heat. Noise occurs and possibly cavitation in suction lines.

Medium

All indications given with regards given concerning flow restrictions and to flow properties refer exclusively to liquids. For gaseous media, the variable density of the gas must additionally be taken into account.

Units

$$c = \text{Flow velocity} \left[\frac{\text{m}}{\text{s}} \right]$$

$$d = \text{Pipe inside diameter [m]}$$

$$L = \text{Pipe length [m]}$$

$$\rho = \text{Pressure [Pa], 1 bar = 100000 Pa}$$

$$\dot{V} = \text{Flow rate} \left[\frac{\text{m}^3}{\text{s}} \right], 1 \frac{\text{m}^3}{\text{s}} = 6000 \frac{\text{l}}{\text{min}}$$

$$\lambda = \text{Pipe friction factor}$$

$$\nu(T) = \text{Kinematic viscosity of the medium depending on temperature} \left[\frac{\text{m}^2}{\text{s}} \right]$$

$$\rho(T) = \text{Density of the medium depending on temperature} \left[\frac{\text{kg}}{\text{m}^3} \right]$$

$$\zeta = \text{Individual pressure loss coefficient}$$

Only base units have been used. This has the advantage that the formulae do not contain correction factors and there is no danger of confusion, e.g. that values are used with the wrong unit. In case values are given in other units – the flow rate is e.g. often given in l/min – it is advisable to convert them into the base units before starting calculation.

Pressure losses in pipe lines

To calculate pressure losses in pipe lines, it must first be determined whether there is a laminar or a turbulent flow. Laminar flow is homogenous and without turbulence. In case of turbulent flow, the losses increase much more quickly.

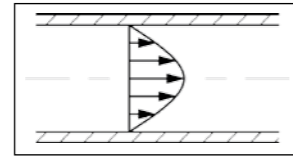

Flow profile with laminar flow

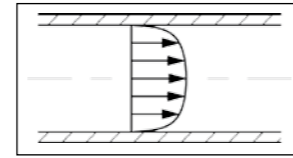

Flow profile with turbulent flow

The kind of flow is defined by the Reynolds' number. With a Reynolds' number of more than 2320, the flow changes to turbulent. The Reynolds' number is calculated according to the formula:

$$Re = \frac{c \cdot d}{\nu(T)}$$

The Reynolds' number is a non-dimensional number. The critical fluid velocity at which the flow regime can change, is thus calculated from:

$$c_{cr} = 2320 \cdot \frac{\nu(T)}{d} \left[\frac{\text{m}}{\text{s}} \right]$$

With a given flow rate, the fluid velocity can be calculated according to the formula:

$$c = \frac{\dot{V} \cdot 4}{d^2 \cdot \pi} \left[\frac{\text{m}}{\text{s}} \right]$$

Subsequently, the pipe friction factor λ is a function of the Reynolds' number and also depends on the roughness of the pipe. As hydraulically smooth pipes can generally be assumed in hydraulic applications, the pipe friction factor λ is calculated according to the following formula:

$$\text{laminar flow, (Re < 2320): } \lambda = \frac{64}{Re}$$

$$\text{turbulent flow, (Re > 2320): } \lambda = \frac{0.3164}{\sqrt[4]{Re}}$$

Finally, if all factors are known, the pressure loss in certain pipe lines can be calculated according to the formula:

$$\Delta p = \lambda \cdot \frac{L}{d} \cdot \frac{\rho(T) \cdot c^2}{2} \text{ [Pa]}$$

Calculation of individual losses

A hydraulic system does not only incorporate pipes, but also valves, fittings, pipe bends etc. that cause flow losses. These individual losses are often much higher than the pipe losses and are calculated according to the following formula:

$$\Delta p = \zeta \cdot \rho(T) \cdot \frac{c^2}{2} \text{ [Pa]}$$

Tube bends

With pipe bends, the pressure loss coefficient results from the ratio of bend to inside diameter (R/d).

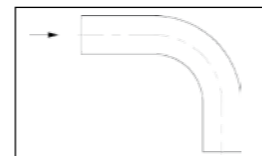

Bend radius/Inside diameter	Pressure loss coefficient ζ
2	0.21
4	0.14
6 and more	0.11

Flow diameter and wall thickness

Determining tube sizes for hydraulic systems

Proper tube material, type and size for a given application and type of fitting are critical for efficient and trouble-free operation of the fluid system. Selection of proper tubing involves choosing the right tube material, and determining the optimum tube size (O.D. and wall thickness).

Proper sizing of the tube for various parts of a hydraulic system results in an optimum combination of efficient and cost effective performance.

A tube that is too small causes high fluid velocity, which has many detrimental effects. In pressure lines, it causes high friction losses and turbulence, both resulting in high pressure drops and heat generation. High heat accelerates wear in moving parts and rapid aging of seals and hoses, all resulting in reduced component life. High heat generation also means wasted energy, and hence, low efficiency.

Too large tubes increase system cost. Thus, optimum tube sizing is very critical. The following is a simple procedure for sizing tubes.

Determine required flow diameter

Use table to determine recommended flow diameter for the required flow rate and type of line.

The table is based on the following recommended flow velocities (DIN 24346):

Avoid flow rates > 8m/s! The resulting forces are high and can destroy the tube lines.	Pressure lines – 3 → 5 $\left[\frac{\text{m}}{\text{s}} \right]$
	Return lines – 2 → 4 $\left[\frac{\text{m}}{\text{s}} \right]$
	Suction lines – 1 $\left[\frac{\text{m}}{\text{s}} \right]$

If you wish to use different velocities than the above, use one of the following formulae to determine the required flow diameter.

$$\text{Tube - I.D. [mm]} = 4,61 \cdot \sqrt{\frac{\text{Flow} \left[\frac{\text{ltr.}}{\text{min}} \right]}{\text{Velocity} \left[\frac{\text{m}}{\text{s}} \right]}}$$

Maximum flow [l/min]	Flow diameter in millimeters		
	5 m/s Pressure lines	3 m/s Return lines	1 m/s suction lines
10	6.5	8.4	14.6
15	8.0	10.3	17.9
20	9.2	11.9	20.6
25	10.3	13.3	23.1
30	11.3	14.6	25.3
35	12.2	15.7	27.3
40	13.0	16.8	29.2
45	13.8	17.9	30.9
50	14.6	18.8	32.6
55	15.3	19.7	34.2
60	16.0	20.6	35.7
65	16.6	21.5	37.2
70	17.2	22.3	38.6
75	17.9	23.1	39.9
80	18.4	23.8	41.2
85	19.0	24.5	42.5
90	19.6	25.3	43.7
95	20.1	25.9	44.9
100	20.6	26.6	46.1
110	21.6	27.9	48.4
120	22.6	29.2	50.5
130	23.5	30.3	52.6
140	24.4	31.5	54.5
150	25.3	32.6	56.5
160	26.1	33.7	58.3
170	26.9	34.7	60.1
180	27.7	35.7	61.8
190	28.4	36.7	63.5
200	29.2	37.6	65.2
220	30.6	39.5	68.4
240	31.9	41.2	71.4
260	33.2	42.9	74.3
280	34.5	44.5	77.1
300	35.7	46.1	79.8
320	36.9	47.6	82.5
340	38.0	49.1	85.0
360	39.1	50.5	87.5
380	40.2	51.9	89.9
400	41.2	53.2	92.2
450	43.7	56.5	97.8
500	46.1	59.5	103.1
550	48.4	62.4	108.1
600	50.5	65.2	112.9
650	52.6	67.9	117.5
700	54.5	70.4	122.0
750	56.5	72.9	126.3
800	58.3	75.3	130.4
850	60.1	77.6	134.4
900	61.8	79.8	138.3
950	63.5	82.0	142.1
1000	65.2	84.2	145.8
1050	66.8	86.2	149.4
1100	68.4	88.3	152.9
1150	69.9	90.3	156.3
1200	71.4	92.2	159.7
1250	72.9	94.1	163.0
1300	74.3	96.0	166.2
1350	75.8	97.8	169.4
1400	77.1	99.6	172.5
1450	78.5	101.4	175.5
1500	79.8	103.1	178.5



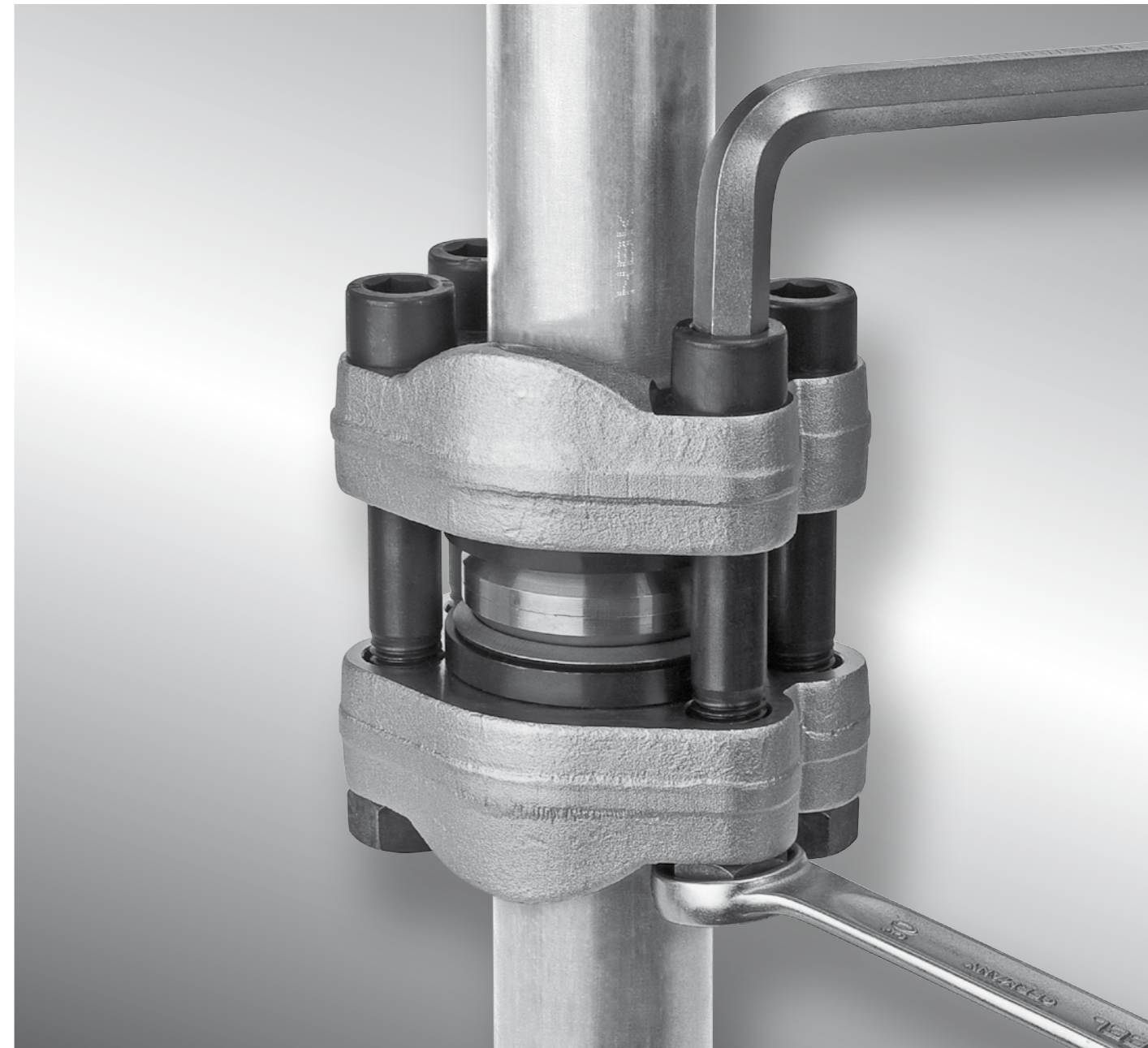

Installation

Tube selection

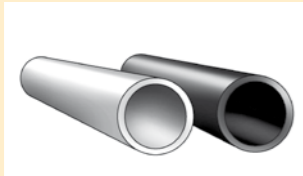

- Select suitable tube material

Selection of flange components

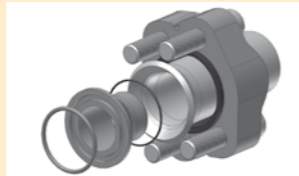

- Choose components acc. to the relevant table
- △ Lockrings and inserts of other producers are strictly permitted!

Tube preparation

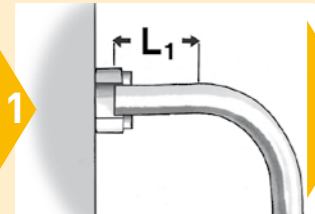

- Minimum straight length L1 before bend

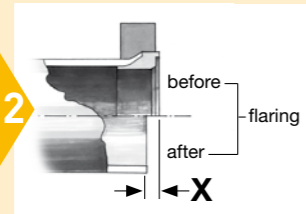

- Tube length before flaring determined by distance X

Tube O.D. x wall thickness mm	Tube length determination X mm	L1 mm
25x3.0	8.0	140
25x4.0	8.5	
30x5.0	8.0	
38x4.0	5.5	
38x5.0	10.0	
38x6.0	12.0	
42x5.0	6.5	
50x5.0	7.0	
50x6.0	6.0	
50x8.0	8.0	
60x8.0	10.0	
65x8.0	8.0	
66x8.5	7.0	
75x12.5	16.5	
80x10.0	16.0	
88x14.0	16.0	

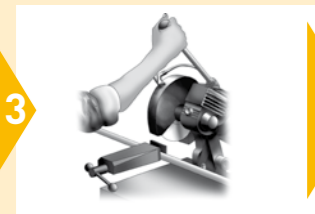

- Cut tube squarely
- max. ± 1° deviation
- △ Burrs can result in sealing problems or tool wear



- Proper deburring and cleaning of inner and outer diameter
- Chamfer 1 mm x 45° max
- △ Burrs can result in sealing problems or tool wear



- Clean tube before flaring
- Adhere to project specification
- △ Dirt can result in sealing problems or tool wear

Tube forming with Parflare® HPF

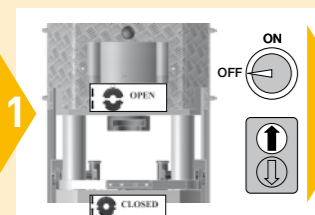

- Open safety cover
- Latch in "OPEN" position
- Cylinder in "BACK" position
- △ Main switch "OFF" during setting



- Select suitable tools according to chart
- Check flaring pin for dirt, wear and damage
- Check flaring dies for dirt, wear and damage

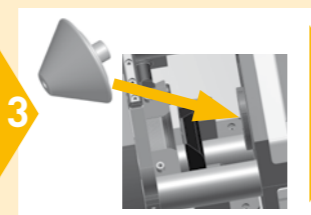

- Insert flaring pin
- Fix with screw

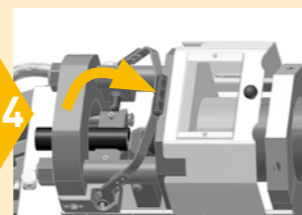

- For inserting clamping jaws clamp in "OPEN" position
- Then insert lower clamping jaw
- Tip lower clamping jaw to make things easier
- Push clamping jaw on guide bolt to stop

Tubeforming with Parflare® HPF



- Adjust tube stop wheel according to chart
- Tighten locking screw for tube stop adjustment



- △ Connections are not to mount without the locking
- Place flange components on tube before flaring
- First of all, place the flange in correct direction
- Then locking in correct direction

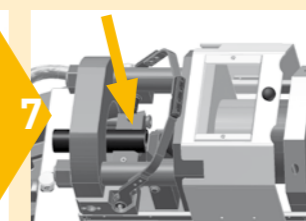

- Insert tube so that it lies against the stop
- Place upper jaw half
- △ Support and secure long and heavy tubes horizontally

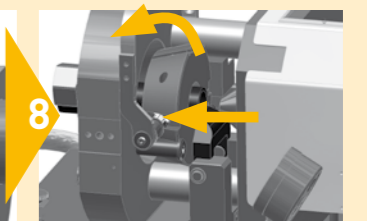

- Swing latch in position "CLOSED"
- Pull clamping jaws with tube into front plate

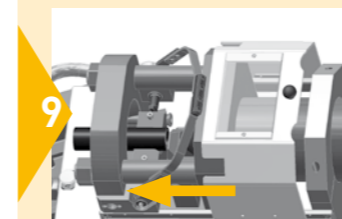

- △ Oil flaring pin with LUBSS
- Close protective hood
- Switch on main switch
- Machine is ready for flaring operation

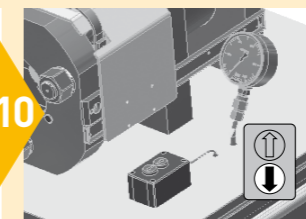

- Start flaring operation by actuating button
- Observe pressure on manometer
- On reaching chart value, end flaring operation
- Run flaring pin to start position

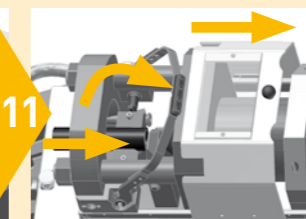

- Open protective hood
- Push tube with clamping jaw completely out of the front plate up to the stop of both guide bolts
- Clamp in "OPEN" position
- Lift upper jaw and remove tube

Tube mm	Tube stop mm	Assembly pressure bar
25x3.0	5.5	100
25x4.0	5.5	150
30x5.0	7.0	200
38x4.0	3.5	150
38x5.0	3.5	200
38x6.0	3.5	300
42x5.0	5.0	400
50x5.0	7.0	250
50x6.0	8.0	300
50x8.0	9.0	600
60x8.0	8.0	500
65x8.0	5.0	300
66x8.5	6.0	500
75x12.5	10.0	700
80x10.0	10.0	700
88x14.0	10.0	700

- Setting values are recommendations only
- Adjust setting to specific tube quality and tolerance

Checking the flare



- Clean flare for inspection
- Check sealing surface for cracks, burrs, scratches and pitting
- ⚠ Do not use any tubing with faulty sealing faces (risk of leakage)

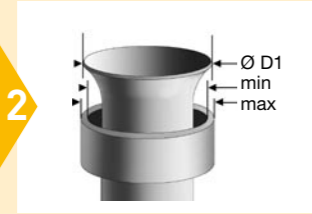

- Dimensional check of the flare according to chart
- ⚠ Do not use any tubing with incorrectly dimensioned flaring diameters

Tube mm	Ø D1 ± 1mm
25x3.0	36.0
25x4.0	36.0
30x5.0	43.0
38x4.0	49.0
38x5.0	49.0
38x6.0	48.5
42x5.0	54.5
50x5.0	65.0
50x6.0	65.0
50x8.0	65.0
60x8.0	78.0
65x8.0	82.0
66x8.5	84.0
75x12.5	92.0
80x10.0	96.5
88x14.0	104.0

Installation HPF Flange connection



- Tube end must be clean
- Fix insert
- If necessary, use plastic hammer
- ⚠ Avoid damage to sealing surfaces



- Lubricate insert



- Check correct seating of sealing rings
- Sealing face must not be dirty or damaged



- Position flange and place bolts
- ⚠ Tube assembly must be stress-free at both ends
- ⚠ Bolts must move freely
- ⚠ Do not use shorter bolts indicated in the catalogue!
- ⚠ Parker recommends to lubricate the bolts



- Hand tighten bolts
- Torque bolts in diagonal sequence from 1 to 4
- Torque bolts in small increments to the appropriate torque level listed in chart



- Be sure the flange seating is correct
- Flange gap must be the same at all 3 points

Flange size	ISO 6162-2		ISO 6164	
	Bolt 10.9	Torque Nm	Bolt 10.9	Torque Nm
3/4"	M10	55		
1"	M12	95		
1 1/4"	M14	130		
1 1/2"	M16	250		
2"	M20	450		
2 1/2"			M16	250
3"			M20	450
4"			M24	650
			M30	1400



Tools for Parflare® machines



- ⚠ Use of worn or non-suitable tooling may result in flange failure and damage of machine
- ⚠ Tools must be checked regularly, at least after 50 assemblies
- ⚠ Worn tools must be replaced
- ⚠ Use only genuine Parker Parts
- ⚠ Tools must always be kept clean and lubricated

Checking instructions for Parflare® HPF tools



- Clean pin for checking
- Visual check: surface must be free of wear and damage



- Clean die halves for checking
- Visual check: gripping surface must be clean and free of wear
- Use wire brush to remove metal particles from gripping surface

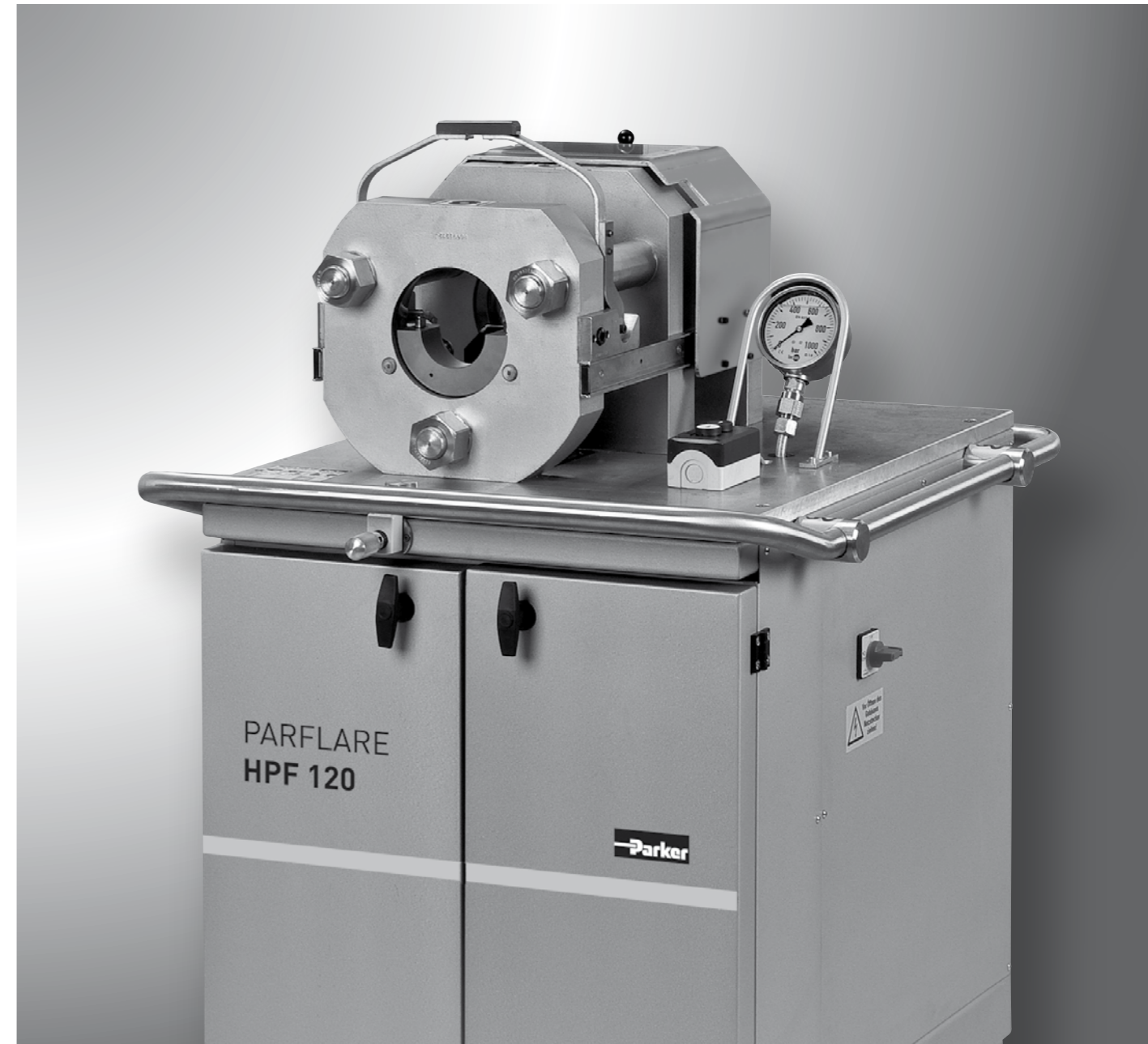

Machine, tooling and equipment

Parflare® HPF 120

Workshop machine for manufacturing HPF flange connections



The machine is designed for project work on site. When the doors are opened, the Parflare® HPF 120 is transformed into a completely equipped WorkCentre. At the front of the machine there is a tool magazine in which all the tools can be viewed and cleanly laid out. The WorkCentre can be manoeuvred on casters as well as by crane or forklift.

The Parflare® HPF 120 is supplied ready to go but tools must be ordered separately. Special clamping jaws and pins are required for each tube size.

Application

- Alternative to conventional welded connections for hydraulic lines
- Workshop machine for project work, on-site assembly and maintenance
- Not suitable for high volume production

The Parflare® HPF 120 has been developed for tube end forming by axial pressure operation for the HPF flange system and is a workshop machine for project operation.

Flange flaring is achieved by axial pressure of the tool into the tube end. The flaring contour matches the Parker HPF insert.

The feed movement of the tool is produced by an hydraulic cylinder which is driven by a unit in the machine housing. The return feed is also electro-hydraulic. The tubes are clamped in clamping jaw sets which are clamped by means of a cone. The machine is equipped with an adjustable stop for the tube end. This enables flared flanges to be produced with consistent quality. The split clamping jaws and the tube stop allow simple operation and consistent results. The separation of the clamping jaws and removal of the tubes is made easier by a latch device.



The Parflare® HPF 120 is a totally equipped WorkCentre for workshop use

Parflare® HPF 120

Specification

Application	Flaring machine for HPF flange connectors
Process	Tube forming by axial pressure
Design	On-site and workshop machine for individual tube preparation
Operation	Manual tube clamping Hydraulic driven tool Process control by setting wheels and pressure display
Tube diameter	25 to 88 mm, optional 120 mm
Tube material	Steel and stainless steel
Cycle time	1 – 2 minutes flaring time 3 – 5 minutes total cycle time
Economic production quantity	max. 50 assemblies per day
Tools	Flaring pin BHPF... Clamping die set MHPF...
Tool lubrication	manual
Lubricant for pin	LUBSS
Machine dimensions (L x W x H)	800 x 910 x 1.320 mm
Weight	approx. 380 kg
Nominal voltage	400 V/3Ph/1.1 kW
Connecting cable	3m/CEE 16A
Sound pressure level	Less than 70 dB (A)

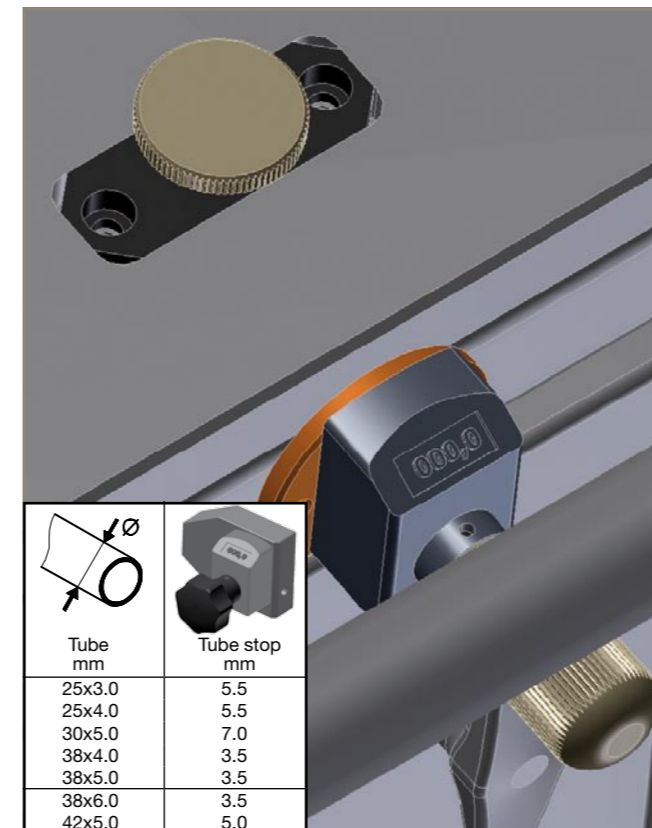

Consistent flaring result is achieved by setting of tube stop.

Parflare® HPF 120

Features, advantages and benefits of Parflare® HPF 120

- 1. Cost saving** – Compared to welding or brazing, orbital flaring is much less time consuming. Special tube preparation and finishing are not necessary. Flaring uses only a fraction of the energy needed for brazing or welding.
- 2. Zinc plated tubing** – The Parflare® process allows the use of zinc-plated tubing. The cost for cleaning post process, or painting can be saved.
- 3. Excellent sealing quality** – The HPF inserts are precisely fitted into the contour of the tube termination. Sealing is achieved by an O-ring.
- 4. Process/Product concept** – Parflare® machines are especially designed to match Parker HPF standards. Machine, tools and products are fine-tuned for reliable performance.
- 5. Workshop use** – The rigid machine design allows project work in on-site piping workshops.
- 6. Short clamping length** – Clamping dies for HPF flaring are optimised for minimum straight tube length.
- 7. Easy to use** – All operational devices are obvious so that machine operation is intuitive. Insertion and withdrawal of the tube ends are facilitated by the two-part clamping jaws.
- 8. Quality** – Consistent quality results are achieved by recommended values for machine setting.
- 9. Constant flare diameter** – The diameter of the flare is given by the tool contour and the tube stop adjustment.
- 10. Flexible** – Different tube material and quality might require special setting of tube stop. For best results, these parameters can be manually adjusted based on operators experience.
- 11. Clean** – The Parflare® process is environmentally clean and safe. As no heat or chemicals are used, hazards from fumes or heat do not occur.
- 12. Perfect for on-site work** – The complete WorkCentre features special attachments for transportation by fork lift and crane. Therefore the Parflare® HPF 120 is ideal for the workshop or on-site use.
- 13. Ready to go** – The Parflare® HPF 120 is delivered including all necessary items such as electric plug, operator manual, declaration of CE-conformity, short instruction pictograms on machine housing and dimensional charts for tube preparation.



Parflare® HPF 120

Ordering

Type	Order code
Parflare® HPF 120 WorkCentre Ready to use, including operating manual, filled with hydraulic oil and lubricant Without tools Basic machine 400 V, 3 phase, 50 Hz	HPF120EU400V
Catalogue 4167/UK	4167 via Parker catalogue service EMDC
Operating manual UK/DE	HPF120/MANUAL
Tool lubricant qty: 1L	LUBSS

Parflare® machines are shipped in special containers which should be kept for future transportation to avoid damage.

Flaring tools for machine: Parflare® HPF 120

	Clamping die set „MHPF“	Pressure pin „BHPF“
		
Tube OD mm	Order code	Order code
25	MHPF25	BHPF25-38
30	MHPF30	BHPF25-38
38	MHPF38	BHPF38-50
42	MHPF42	BHPF38-50
50	MHPF50	BHPF38-50
60	MHPF60	BHPF50-80
65	MHPF65	BHPF50-80
66	MHPF66	BHPF50-80
75	MHPF75	BHPF50-80
80	MHPF80	BHPF50-80
88	MHPF88	BHPF50-80

Tool lifetime

Assembly tools are subject to wear and must be regularly (max. 50 assemblies) cleaned and checked (for checking instructions see chapter E).

Worn tools can cause dangerous assembly failures and must be replaced in time. Average tool lifetime is approx. 5000 cycles when properly used. Maximum lifetime can be achieved by observing the following:

- Regular cleaning and checking
- Clean and corrosion-protected storage
- Proper de-burring and cleaning of tube end
- Proper tool selection and operation
- Use of specified lubricant

50 6164 Square flange

C - Complete flange with metric thread holes incl. locking

6164

Size	Tube OD	LK	D1	D2	L1	LA	LX	DB	Weight (Steel) kg/1 piece	Order code
3/4"	25	50	32.5	42.1	22.0	50	35.4	9.0	0.25	HPFC412-25
1"	30	62	38.9	48.4	33.0	65	43.8	11.0	0.45	HPFC416-30
1"	38	73	44.6	54.8	36.5	75	51.6	13.5	0.60	HPFC416-38
1 1/4"	42	73	44.6	54.8	37.5	75	51.6	13.5	0.60	HPFC420-38
1 1/4"	50	85	51.6	64.3	42.5	90	60.1	17.5	0.85	HPFC420-42
1 1/2"	50	98	67.6	80.2	40.0	100	69.3	17.5	1.00	HPFC424-50
2"	60	118	80.5	95.0	50.0	120	83.4	22.0	1.40	HPFC432-50
2 1/2"	65	118	80.5	95.0	50.0	120	83.4	22.0	1.60	HPFC432-60
2 1/2"	66	118	80.5	95.0	50.0	120	83.4	22.0	1.60	HPFC440-60
2 1/2"	75	118	80.5	95.0	55.0	150	102.5	26.0	2.00	HPFC440-65
2 1/2"	75	145	90.5	111.0	56.0	150	102.5	26.0	2.00	HPFC440-66
2 1/2"	75	145	90.5	111.0	56.0	150	102.5	26.0	2.00	HPFC440-75

Ordering information/Nomenclature

Order code – HPF

Example: **HPF6 20 -42x3.0 V CF**

Part Code	Flange	Flange	Footprint
Flange	Type	Code	(SAE6000)
HPF	6	ISO 6162-2	Square flange
HPF	4	ISO 6164	Square flange

Series									
8	12	16	20	24	32	40	48	64	80
1/2"	3/4"	1"	1 1/4"	1 1/2"	2"	2 1/2"	3"	4"	5"

Pipe size	
42x3.0 / Pipe O.D. x wall thickness (mm)	

Sealing System	
V	F37 Seal
F	Flat Face

Material and coating	
CF	Steel, Cr(VI)-free
SS	Stainless steel



Ordering example for a tube-to-port flange connection:

Part code	Component	Qty.	Code	Material
HPF620-38X6.0VCF	Flange	1	HPFC620-38CFX	Steel, Cr(VI)-free
Tube to port	Insert	1	IP20-38X6.0VCFX	Steel, Cr(VI)-free
1 1/4" 6000psi Footprint	F37 seal	1	F37S20X	P5008
38X6.0 tube	O-ring	1	OR29.87X1.78	NBR, 90° Shore
	Bolts	4	ZYLS10X75109	10.9

Order code – HPF

ISO 6162-2/SAE 6000 System

Size	Tube	Flange with locking		Insert for		F37 Seal	Tube seal O-ring
		Plain holes	Threaded holes	F37 Seal	Flat version		
3/4"	25x3.0	HPFC612-25	HPFCM612-25	IP612-25X3.0V	IP612-25X3.0F	F37S12	OR25.12X1.78
3/4"	25x4.0	HPFC612-25	HPFCM612-25	IP612-25X4.0V	IP612-25X4.0F	F37S12	OR23.52X1.78
1"	30x4.0	HPFC616-30	HPFCM616-30	IP616-30X4.0V	IP616-30X4.0F	F37S16	OR28.30X1.78
1"	30x5.0	HPFC616-30	HPFCM616-30	IP616-30X5.0V	IP616-30X5.0F	F37S16	OR26.70X1.78
1"	38x4.0	HPFC616-38	HPFCM616-38	IP616-38X4.0V	IP616-38X4.0F	F37S16	OR36.27X1.78
1"	38x6.0	HPFC616-38	HPFCM616-38	IP616-38X6.0V	IP616-38X6.0F	F37S16	OR29.87X1.78
1 1/4"	38x4.0	HPFC620-38	HPFCM620-38	IP620-38X4.0V	IP620-38X4.0F	F37S20	OR36.27X1.78
1 1/4"	38x5.0	HPFC620-38	HPFCM620-38	IP620-38X5.0V	IP620-38X5.0F	F37S20	OR36.27X1.78
1 1/4"	38x6.0	HPFC620-38	HPFCM620-38	IP620-38X6.0V	IP620-38X6.0F	F37S20	OR29.87X1.78
1 1/4"	42x5.0	HPFC620-42	HPFCM620-42	IP620-42X5.0V	IP620-42X5.0F	F37S20	OR37.82X1.78
1 1/2"	50x3.0	HPFC624-50	HPFCM624-50	IP624-50X3.0V	IP624-50X3.0F	F37S24	OR50.52X1.78
1 1/2"	50x5.0	HPFC624-50	HPFCM624-50	IP624-50X5.0V	IP624-50X5.0F	F37S24	OR50.52X1.78
1 1/2"	50x6.0	HPFC624-50	HPFCM624-50	IP624-50X6.0V	IP624-50X6.0F	F37S24	OR47.37X1.78
1 1/2"	50x8.0	HPFC624-50	HPFCM624-50	IP624-50X8.0V	IP624-50X8.0F	F37S24	OR44.17X1.78
2"	50x5.0	HPFC632-50	HPFCM632-50	IP632-50X5.0V	IP632-50X5.0F	F37S32	OR50.52X1.78
2"	50x6.0	HPFC632-50	HPFCM632-50	IP632-50X6.0V	IP632-50X6.0F	F37S32	OR50.52X1.78
2"	50x8.0	HPFC632-50	HPFCM632-50	IP632-50X8.0V	IP632-50X8.0F	F37S32	OR44.17X1.78
2"	60x8.0	HPFC632-60	HPFCM632-60	IP632-60X8.0V	IP632-60X8.0F	F37S32	OR56.87X1.78
2"	65x8.0	HPFC632-65	HPFCM632-65	IP632-65X8.0V	IP632-65X8.0F	F37S32	OR60.05X1.78
2"	66x8.5	HPFC632-66	HPFCM632-66	IP632-66X8.5V	IP632-66X8.5F	F37S32	OR60.05X1.78

ISO 6164/Square flange System

Size	Tube	Flange with locking		Insert for		F37 Seal	Tube seal O-ring
		Plain holes	Threaded holes	F37 Seal	Flat version		
3/4"	25x3.0	HPFC412-25	---	IP612-25X3.0V	IP612-25X3.0F	F37S12	OR25.12X1.78
3/4"	25x4.0	HPFC412-25	---	IP612-25X4.0V	IP612-25X4.0F	F37S12	OR23.52X1.78
1"	30x4.0	HPFC416-30	---	IP616-30X4.0V	IP616-30X4.0F	F37S16	OR28.30X1.78
1"	30x5.0	HPFC416-30	---	IP616-30X5.0V	IP616-30X5.0F	F37S16	OR26.70X1.78
1"	38x4.0	HPFC416-38	---	IP616-38X4.0V	IP616-38X4.0F	F37S16	OR36.27X1.78
1"	38x6.0	HPFC416-38	---	IP616-38X6.0V	IP616-38X6.0F	F37S16	OR29.87X1.78
1 1/4"	38x4.0	HPFC420-38	---	IP620-38X4.0V	IP620-38X4.0F	F37S20	OR36.27X1.78
1 1/4"	38x5.0	HPFC420-38	---	IP620-38X5.0V	IP620-38X5.0F	F37S20	OR36.27X1.78
1 1/4"	38x6.0	HPFC420-38	---	IP620-38X6.0V	IP620-38X6.0F	F37S20	OR29.87X1.78
1 1/4"	42x5.0	HPFC420-42	---	IP620-42X5.0V	IP620-42X5.0F	F37S20	OR37.82X1.78
1 1/2"	50x3.0	HPFC424-50	---	IP624-50X3.0V	IP624-50X3.0F	F37S24	OR50.52X1.78
1 1/2"	50x5.0	HPFC424-50	---	IP624-50X5.0V	IP624-50X5.0F	F37S24	OR50.52X1.78
1 1/2"	50x6.0	HPFC424-50	---	IP624-50X6.0V	IP624-50X6.0F	F37S24	OR47.37X1.78
1 1/2"	50x8.0	HPFC424-50	---	IP624-50X8.0V	IP624-50X8.0F	F37S24	OR44.17X1.78
2"	50x5.0	HPFC432-50	---	IP432-50X5.0V	IP632-50X5.0F	F37S32	OR50.52X1.78
2"	50x6.0	HPFC432-50	---	IP432-50X6.0V	IP632-50X6.0F	F37S32	OR50.52X1.78
2"	50x8.0	HPFC432-50	---	IP432-50X8.0V	IP632-50X8.0F	F37S32	OR44.17X1.78
2 1/2"	60x8.0	HPFC432-60	---	IP440-60X8.0V	IP432-60X8.0F	F37S40	OR56.87X1.78
2 1/2"	65x8.0	HPFC432-65	---	IP440-65X8.0V	IP432-65X8.0F	F37S40	OR60.05X1.78
2 1/2"	66x8.5	HPFC432-66	---	IP440-66X8.5V	IP432-66X8.5F	F37S40	OR60.05X1.78
2 1/2"	75x12.5	HPFC440-75	---	IP440-75X12.5V	IP440-75X12.5F	F37S40	OR72.75X1.78
3"	80x3.0	HPFC448-80	---	IP448-80X3.0V	IP448-80X3.0F	F37S48	OR82.27X1.78
3"	80x8.0	HPFC448-80	---	IP448-80X8.0V	IP448-80X8.0F	F37S48	OR72.75X1.78
3"	80x10.0	HPFC448-80	---	IP448-80X10.0V	IP448-80X10.0F	F37S48	OR69.57X1.78
3"	88x14.0	HPFC448-88	---	IP448-88X14.0V	IP448-88X14.0F	F37S48	OR72.75X1.78

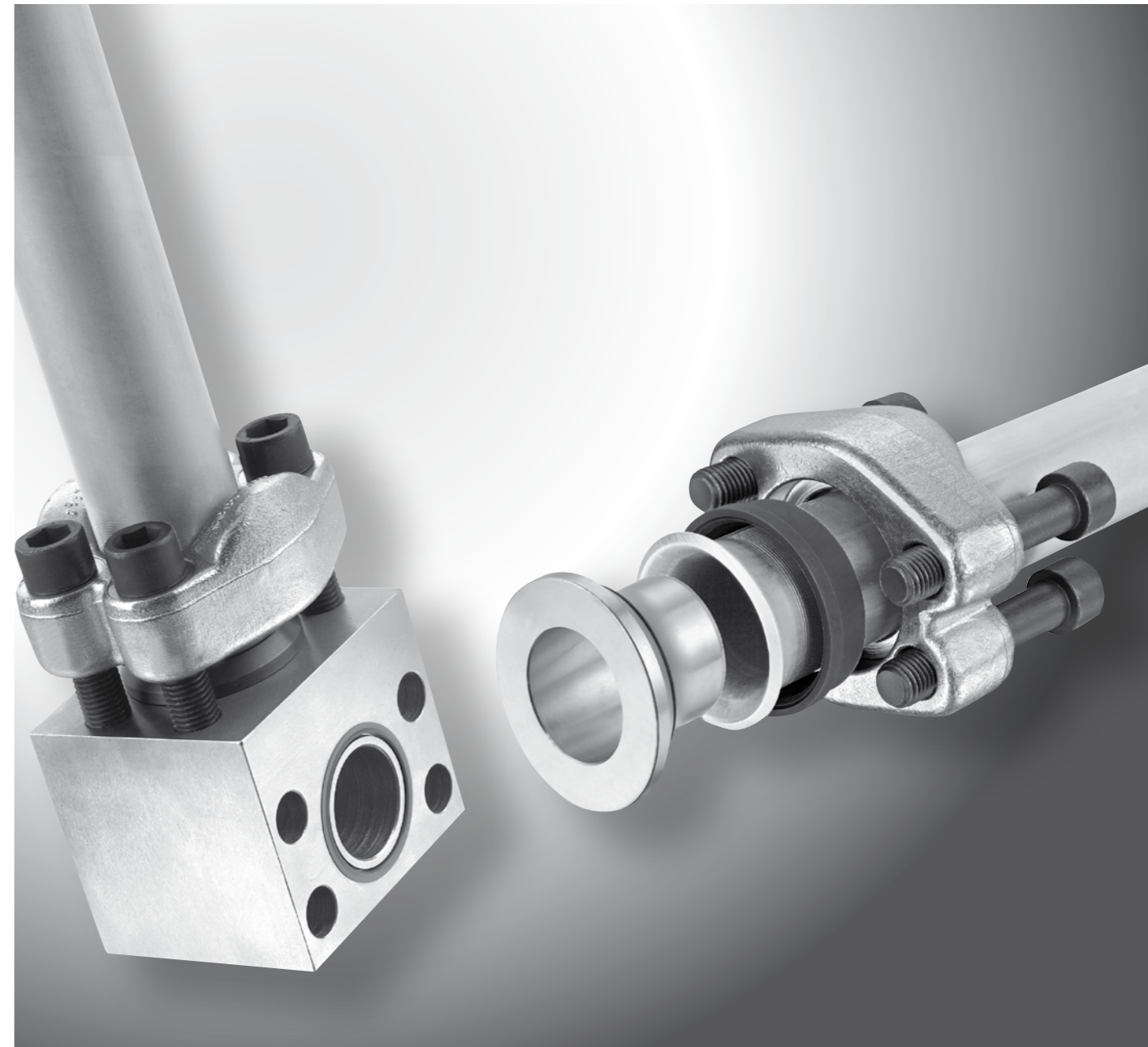

HPF – SAE 6000/ISO 6162-2

HPF – Tube-to-tube connection

Overview of tube-to-tube connection, Flanges with through boring, bolts and nuts

Example 38x4.0 in 1": 1x Flange connection complete with profile seal HPF616-38X4.0-V
 1x Flange connection complete flat version HPFM616-38X4.0-F
 4x Bolts M12x110
 4x Nuts M12-10

**Flange connection 1
 ISO 6162-2 with F37 profile seal**

Size	Tube	Flange connection complete	Flange connection consists of				Bolts 10.9 ISO 4762 4x	Nut ISO 4032 4x
			Insert 1x	Flange incl. locking 1x	Flange seal F37 sealing ring 1x	Tube seal O-ring 1x		
3/4"	25x3.0	HPF612-25X3.0-V	IP612-25X3.0V	HPFC612-25	F37S12	OR25.12X1.78	M10x90	M10-10
3/4"	25x4.0	HPF612-25X4.0-V	IP612-25X4.0V	HPFC612-25	F37S12	OR23.52X1.78	M10x90	M10-10
1"	30x4.0	HPF616-30X4.0-V	IP616-30X4.0V	HPFC616-30	F37S16	OR28.30X1.78	M12x110	M12-10
1"	30x5.0	HPF616-30X5.0-V	IP616-30X5.0V	HPFC616-30	F37S16	OR26.70X1.78	M12x110	M12-10
1"	38x4.0	HPF616-38X4.0-V	IP616-38X4.0V	HPFC616-38	F37S16	OR36.27X1.78	M12x110	M12-10
1"	38x6.0	HPF616-38X6.0-V	IP616-38X6.0V	HPFC616-38	F37S16	OR29.87X1.78	M12x110	M12-10
1 1/4"	38x4.0	HPF620-38X4.0-V	IP620-38X4.0V	HPFC620-38	F37S20	OR36.27X1.78	M14x120	M14-10
1 1/4"	38x5.0	HPF620-38X5.0-V	IP620-38X5.0V	HPFC620-38	F37S20	OR36.27X1.78	M14x120	M14-10
1 1/4"	38x6.0	HPF620-38X6.0-V	IP620-38X6.0V	HPFC620-38	F37S20	OR29.87X1.78	M14x120	M14-10
1 1/4"	42x5.0	HPF620-42X5.0-V	IP620-42X5.0V	HPFC620-42	F37S20	OR37.82X1.78	M14x120	M14-10
1 1/2"	50x3.0	HPF624-50X3.0-V	IP624-50X3.0V	HPFC624-50	F37S24	OR50.52X1.78	M16x150	M16-10
1 1/2"	50x5.0	HPF624-50X5.0-V	IP624-50X5.0V	HPFC624-50	F37S24	OR50.52X1.78	M16x150	M16-10
1 1/2"	50x6.0	HPF624-50X6.0-V	IP624-50X6.0V	HPFC624-50	F37S24	OR47.37X1.78	M16x150	M16-10
1 1/2"	50x8.0	HPF624-50X8.0-V	IP624-50X8.0V	HPFC624-50	F37S24	OR44.17X1.78	M16x150	M16-10
2"	50x5.0	HPF632-50X5.0-V	IP632-50X5.0V	HPFC632-50	F37S32	OR50.52X1.78	M20x160	M20-10
2"	50x6.0	HPF632-50X6.0-V	IP632-50X6.0V	HPFC632-50	F37S32	OR50.52X1.78	M20x160	M20-10
2"	50x8.0	HPF632-50X8.0-V	IP632-50X8.0V	HPFC632-50	F37S32	OR44.17X1.78	M20x160	M20-10
2"	60x8.0	HPF632-60X8.0-V	IP632-60X8.0V	HPFC632-60	F37S32	OR56.87X1.78	M20x160	M20-10
2"	65x8.0	HPF632-65X8.0-V	IP632-65X8.0V	HPFC632-65	F37S32	OR60.05X1.78	M20x160	M20-10
2"	66x8.5	HPF632-66X8.5-V	IP632-66X8.5V	HPFC632-66	F37S32	OR60.05X1.78	M20x160	M20-10

**Flange connection 2
 ISO 6162-2 flat face**

Size	Tube	Flange connection complete	Flange connection consists of		
			Insert 1x	Flange incl. locking 1x	Tube seal O-ring 1x
3/4"	25x3.0	HPF612-25X3.0-F	IP612-25X3.0F	HPFC612-25	OR25.12X1.78
3/4"	25x4.0	HPF612-25X4.0-F	IP612-25X4.0F	HPFC612-25	OR23.52X1.78
1"	30x4.0	HPF616-30X4.0-F	IP616-30X4.0F	HPFC616-30	OR28.30X1.78
1"	30x5.0	HPF616-30X5.0-F	IP616-30X5.0F	HPFC616-30	OR26.70X1.78
1"	38x4.0	HPF616-38X4.0-F	IP616-38X4.0F	HPFC616-38	OR36.27X1.78
1"	38x6.0	HPF616-38X6.0-F	IP616-38X6.0F	HPFC616-38	OR29.87X1.78
1 1/4"	38x4.0	HPF620-38X4.0-F	IP620-38X4.0F	HPFC620-38	OR36.27X1.78
1 1/4"	38x5.0	HPF620-38X5.0-F	IP620-38X5.0F	HPFC620-38	OR36.27X1.78
1 1/4"	38x6.0	HPF620-38X6.0-F	IP620-38X6.0F	HPFC620-38	OR29.87X1.78
1 1/4"	42x5.0	HPF620-42X5.0-F	IP620-42X5.0F	HPFC620-42	OR37.82X1.78
1 1/2"	50x3.0	HPF624-50X3.0-F	IP624-50X3.0F	HPFC624-50	OR50.52X1.78
1 1/2"	50x5.0	HPF624-50X5.0-F	IP624-50X5.0F	HPFC624-50	OR50.52X1.78
1 1/2"	50x6.0	HPF624-50X6.0-F	IP624-50X6.0F	HPFC624-50	OR47.37X1.78
1 1/2"	50x8.0	HPF624-50X8.0-F	IP624-50X8.0F	HPFC624-50	OR44.17X1.78
2"	50x5.0	HPF632-50X5.0-F	IP632-50X5.0F	HPFC632-50	OR50.52X1.78
2"	50x6.0	HPF632-50X6.0-F	IP632-50X6.0F	HPFC632-50	OR50.52X1.78
2"	50x8.0	HPF632-50X8.0-F	IP632-50X8.0F	HPFC632-50	OR44.17X1.78
2"	60x8.0	HPF632-60X8.0-F	IP632-60X8.0F	HPFC632-60	OR56.87X1.78
2"	65x8.0	HPF632-65X8.0-F	IP632-65X8.0F	HPFC632-65	OR60.05X1.78
2"	66x8.5	HPF632-66X8.5-F	IP632-66X8.5F	HPFC632-66	OR60.05X1.78



HPF – Tube-to-tube connection

Overview of tube-to-tube connection, 1 Flange with tapped holes, 1 Flange with through boring, bolts

Example 38x4.0 in 1": 1x Flange connection complete with profile seal HPF616-38x4.0-V
 1x Flange connection complete flat version HPFM616-38x4.0-F
 4x Nuts M12x90

**Flange connection 1
 ISO 6162-2 with F37 profile sealing**

Size	Tube	Flange connection complete	Flange connection consists of				Nuts 10.9 ISO 4762 4x
			Insert 1x	Flange 1x	Flange seal F37 sealing ring 1x	Tube seal O-ring 1x	
3/4"	25x3.0	HPF612-25x3.0-V	IP612-25x3.0V	HPFC612-25	F37S12	OR25.12x1.78	M10x70
3/4"	25x4.0	HPF612-25x4.0-V	IP612-25x4.0V	HPFC612-25	F37S12	OR23.52x1.78	M10x70
1"	30x4.0	HPF616-30x4.0-V	IP616-30x4.0V	HPFC616-30	F37S16	OR28.30x1.78	M12x90
1"	30x5.0	HPF616-30x5.0-V	IP616-30x5.0V	HPFC616-30	F37S16	OR26.70x1.78	M12x90
1"	35x5.0	HPF616-35x5.0-V	IP616-35x5.0V	HPFC616-35	F37S16	OR31.47x1.78	M12x90
1"	38x4.0	HPF616-38x4.0-V	IP616-38x4.0V	HPFC616-38	F37S16	OR36.27x1.78	M12x90
1"	38x6.0	HPF616-38x6.0-V	IP616-38x6.0V	HPFC616-38	F37S16	OR29.87x1.78	M12x90
1 1/4"	38x4.0	HPF620-38x4.0-V	IP620-38x4.0V	HPFC620-38	F37S20	OR36.27x1.78	M14x100
1 1/4"	38x5.0	HPF620-38x5.0-V	IP620-38x5.0V	HPFC620-38	F37S20	OR36.27x1.78	M14x100
1 1/4"	38x6.0	HPF620-38x6.0-V	IP620-38x6.0V	HPFC620-38	F37S20	OR29.87x1.78	M14x100
1 1/4"	42x5.0	HPF620-42x5.0-V	IP620-42x5.0V	HPFC620-42	F37S20	OR37.82x1.78	M14x100
1 1/2"	50x3.0	HPF624-50x3.0-V	IP624-50x3.0V	HPFC624-50	F37S24	OR50.52x1.78	M16x130
1 1/2"	50x5.0	HPF624-50x5.0-V	IP624-50x5.0V	HPFC624-50	F37S24	OR50.52x1.78	M16x130
1 1/2"	50x6.0	HPF624-50x6.0-V	IP624-50x6.0V	HPFC624-50	F37S24	OR47.37x1.78	M16x130
1 1/2"	50x8.0	HPF624-50x8.0-V	IP624-50x8.0V	HPFC624-50	F37S24	OR44.17x1.78	M16x130
2"	50x5.0	HPF632-50x5.0-V	IP632-50x5.0V	HPFC632-50	F37S32	OR50.52x1.78	M20x140
2"	50x6.0	HPF632-50x6.0-V	IP632-50x6.0V	HPFC632-50	F37S32	OR50.52x1.78	M20x140
2"	50x8.0	HPF632-50x8.0-V	IP632-50x8.0V	HPFC632-50	F37S32	OR44.17x1.78	M20x140
2"	60x8.0	HPF632-60x8.0-V	IP632-60x8.0V	HPFC632-60	F37S32	OR56.87x1.78	M20x140
2"	65x8.0	HPF632-65x8.0-V	IP632-65x8.0V	HPFC632-65	F37S32	OR60.05x1.78	M20x140
2"	66x8.5	HPF632-66x8.5-V	IP632-66x8.5V	HPFC632-66	F37S32	OR60.05x1.78	M20x140

**Flange connection 2
 ISO 6162-2 flat version**

Size	Tube	Flange connection complete	Flange connection consists of		
			Insert 1x	Flange incl. locking 1x	Tube seal O-ring 1x
3/4"	25x3.0	HPFM612-25x3.0-F	IP612-25x3.0F	HPFCM612-25	OR25.12x1.78
3/4"	25x4.0	HPFM612-25x4.0-F	IP612-25x4.0F	HPFCM612-25	OR23.52x1.78
1"	30x4.0	HPFM616-30x4.0-F	IP616-30x4.0F	HPFCM616-30	OR28.30x1.78
1"	30x5.0	HPFM616-30x5.0-F	IP616-30x5.0F	HPFCM616-30	OR26.70x1.78
1"	35x5.0	HPFM616-35x5.0-F	IP616-35x5.0F	HPFCM616-35	OR31.47x1.78
1"	38x4.0	HPFM616-38x4.0-F	IP616-38x4.0F	HPFCM616-38	OR36.27x1.78
1"	38x6.0	HPFM616-38x6.0-F	IP616-38x6.0F	HPFCM616-38	OR29.87x1.78
1 1/4"	38x4.0	HPFM620-38x4.0-F	IP620-38x4.0F	HPFCM620-38	OR36.27x1.78
1 1/4"	38x5.0	HPFM620-38x5.0-F	IP620-38x5.0F	HPFCM620-38	OR36.27x1.78
1 1/4"	38x6.0	HPFM620-38x6.0-F	IP620-38x6.0F	HPFCM620-38	OR29.87x1.78
1 1/4"	42x5.0	HPFM620-42x5.0-F	IP620-42x5.0F	HPFCM620-42	OR37.82x1.78
1 1/2"	50x3.0	HPFM624-50x3.0-F	IP624-50x3.0F	HPFCM624-50	OR50.52x1.78
1 1/2"	50x5.0	HPFM624-50x5.0-F	IP624-50x5.0F	HPFCM624-50	OR50.52x1.78
1 1/2"	50x6.0	HPFM624-50x6.0-F	IP624-50x6.0F	HPFCM624-50	OR47.37x1.78
1 1/2"	50x8.0	HPFM624-50x8.0-F	IP624-50x8.0F	HPFCM624-50	OR44.17x1.78
2"	50x5.0	HPFM632-50x5.0-F	IP632-50x5.0F	HPFCM632-50	OR50.52x1.78
2"	50x6.0	HPFM632-50x6.0-F	IP632-50x6.0F	HPFCM632-50	OR50.52x1.78
2"	50x8.0	HPFM632-50x8.0-F	IP632-50x8.0F	HPFCM632-50	OR44.17x1.78
2"	60x8.0	HPFM632-60x8.0-F	IP632-60x8.0F	HPFCM632-60	OR56.87x1.78
2"	65x8.0	HPFM632-65x8.0-F	IP632-65x8.0F	HPFCM632-65	OR60.05x1.78
2"	66x8.5	HPFM632-66x8.5-F	IP632-66x8.5F	HPFCM632-66	OR60.05x1.78

HPF – Tube-to-port connection

Overview tube-to-port connection with profile seal

Example 38x4.0 in 1": 1x Flange connection complete with profile seal HPF616-38X4.0-V
4x Bolts M12x60

ISO 6162-2 with F37 profile seal

Size	Tube	Flange connection complete	Flange connection consists of				Bolts 10.9 ISO 4762 4x
			Insert 1x	Flange incl. lockring 1x	Flange seal F37 sealing ring 1x	Tube seal O-ring 1x	
3/4"	25x3.0	HPF612-25X3.0-V	IP612-25X3.0V	HPFC612-25	F37S12	OR25.12X1.78	M10x50
3/4"	25x4.0	HPF612-25X4.0-V	IP612-25X4.0V	HPFC612-25	F37S12	OR23.52X1.78	M10x50
1"	30x4.0	HPF616-30X4.0-V	IP616-30X4.0V	HPFC616-30	F37S16	OR28.30X1.78	M12x60
1"	30x5.0	HPF616-30X5.0-V	IP616-30X5.0V	HPFC616-30	F37S16	OR26.70X1.78	M12x60
1"	38x4.0	HPF616-38X4.0-V	IP616-38X4.0V	HPFC616-38	F37S16	OR36.27X1.78	M12x60
1"	38x6.0	HPF616-38X6.0-V	IP616-38X6.0V	HPFC616-38	F37S16	OR29.87X1.78	M12x60
1 1/4"	38x4.0	HPF620-38X4.0-V	IP620-38X4.0V	HPFC620-38	F37S20	OR36.27X1.78	M14x70
1 1/4"	38x5.0	HPF620-38X5.0-V	IP620-38X5.0V	HPFC620-38	F37S20	OR36.27X1.78	M14x70
1 1/4"	38x6.0	HPF620-38X6.0-V	IP620-38X6.0V	HPFC620-38	F37S20	OR29.87X1.78	M14x70
1 1/4"	42x5.0	HPF620-42X5.0-V	IP620-42X5.0V	HPFC620-42	F37S20	OR37.82X1.78	M14x70
1 1/2"	50x3.0	HPF624-50X3.0-V	IP624-50X3.0V	HPFC624-50	F37S24	OR50.52X1.78	M16x80
1 1/2"	50x5.0	HPF624-50X5.0-V	IP624-50X5.0V	HPFC624-50	F37S24	OR50.52X1.78	M16x80
1 1/2"	50x6.0	HPF624-50X6.0-V	IP624-50X6.0V	HPFC624-50	F37S24	OR47.37X1.78	M16x80
1 1/2"	50x8.0	HPF624-50X8.0-V	IP624-50X8.0V	HPFC624-50	F37S24	OR44.17X1.78	M16x80
2"	50x5.0	HPF632-50X5.0-V	IP632-50X5.0V	HPFC632-50	F37S32	OR50.52X1.78	M20x100
2"	50x6.0	HPF632-50X6.0-V	IP632-50X6.0V	HPFC632-50	F37S32	OR50.52X1.78	M20x100
2"	50x8.0	HPF632-50X8.0-V	IP632-50X8.0V	HPFC632-50	F37S32	OR44.17X1.78	M20x100
2"	60x8.0	HPF632-60X8.0-V	IP632-60X8.0V	HPFC632-60	F37S32	OR56.87X1.78	M20x100
2"	65x8.0	HPF632-65X8.0-V	IP632-65X8.0V	HPFC632-65	F37S32	OR60.05X1.78	M20x100
2"	66x8.5	HPF632-66X8.5-V	IP632-66X8.5V	HPFC632-66	F37S32	OR60.05X1.78	M20x100

Overview of tube-to-port connector with flat seal

Example 38x4.0 in 1": 1x Flange connection complete with flat seal HPF616-38X4.0-F
4x Bolts M12x60

ISO 6162-2 flat face

Size	Tube	Flange connection complete	Flange connection consists of			Bolts 10.9 ISO 4762 4x
			Insert 1x	Flange incl. lockring 1x	Tube seal O-ring 1x	
3/4"	25x3.0	HPF612-25X3.0-F	IP612-25X3.0F	HPFC612-25	OR25.12X1.78	M10x50
3/4"	25x4.0	HPF612-25X4.0-F	IP612-25X4.0F	HPFC612-25	OR23.52X1.78	M10x50
1"	30x4.0	HPF616-30X4.0-F	IP616-30X4.0F	HPFC616-30	OR28.30X1.78	M12x60
1"	30x5.0	HPF616-30X5.0-F	IP616-30X5.0F	HPFC616-30	OR26.70X1.78	M12x60
1"	38x4.0	HPF616-38X4.0-F	IP616-38X4.0F	HPFC616-38	OR36.27X1.78	M12x60
1"	38x6.0	HPF616-38X6.0-F	IP616-38X6.0F	HPFC616-38	OR29.87X1.78	M12x60
1 1/4"	38x4.0	HPF620-38X4.0-F	IP620-38X4.0F	HPFC620-38	OR36.27X1.78	M14x70
1 1/4"	38x5.0	HPF620-38X5.0-F	IP620-38X5.0F	HPFC620-38	OR36.27X1.78	M14x70
1 1/4"	38x6.0	HPF620-38X6.0-F	IP620-38X6.0F	HPFC620-38	OR29.87X1.78	M14x70
1 1/4"	42x5.0	HPF620-42X5.0-F	IP620-42X5.0F	HPFC620-42	OR37.82X1.78	M14x70
1 1/2"	50x3.0	HPF624-50X3.0-F	IP624-50X3.0F	HPFC624-50	OR50.52X1.78	M16x80
1 1/2"	50x5.0	HPF624-50X5.0-F	IP624-50X5.0F	HPFC624-50	OR50.52X1.78	M16x80
1 1/2"	50x6.0	HPF624-50X6.0-F	IP624-50X6.0F	HPFC624-50	OR47.37X1.78	M16x80
1 1/2"	50x8.0	HPF624-50X8.0-F	IP624-50X8.0F	HPFC624-50	OR44.17X1.78	M16x80
2"	50x5.0	HPF632-50X5.0-F	IP632-50X5.0F	HPFC632-50	OR50.52X1.78	M20x100
2"	50x6.0	HPF632-50X6.0-F	IP632-50X6.0F	HPFC632-50	OR50.52X1.78	M20x100
2"	50x8.0	HPF632-50X8.0-F	IP632-50X8.0F	HPFC632-50	OR44.17X1.78	M20x100
2"	60x8.0	HPF632-60X8.0-F	IP632-60X8.0F	HPFC632-60	OR56.87X1.78	M20x100
2"	65x8.0	HPF632-65X8.0-F	IP632-65X8.0F	HPFC632-65	OR60.05X1.78	M20x100
2"	66x8.5	HPF632-66X8.5-F	IP632-66X8.5F	HPFC632-66	OR60.05X1.78	M20x100

HPFC – Full flange incl. lockring

ISO 6162-2

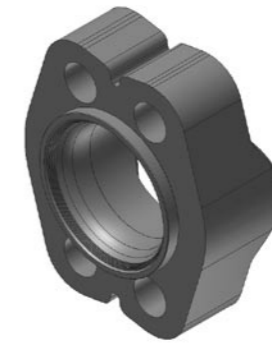

Size	Tube OD	D1	L1	L2	LA	LB	LX	LY	DB	Weight (Steel) kg/1 piece	Order code	PN (bar)
3/4"	25	25.5	33	19	60	71.4	23.8	50.8	10.5	0.5	HPFC612-25	420
1"	30	35.5	39	24	70	81.0	27.8	57.2	13.0	0.5	HPFC616-30	420
1"	38	38.5	39	24	70	81.0	27.8	57.2	13.0	0.6	HPFC616-38	420
1 1/4"	38	38.5	44	27	78	96.0	31.8	66.6	15.0	0.9	HPFC620-38	420
1 1/4"	42	42.5	44	27	78	96.0	31.8	66.6	15.0	0.9	HPFC620-42	420
1 1/2"	50	50.5	48	30	96	113.0	36.5	79.3	17.0	1.5	HPFC624-50	420
2"	50	50.5	58	37	114	134.0	44.5	96.8	22.0	2.5	HPFC632-50	420
2"	60	60.5	62	37	114	134.0	44.5	96.8	22.0	2.4	HPFC632-60	420
2"	65	65.5	62	37	114	134.0	44.5	96.8	22.0	2.3	HPFC632-65	420
2"	66	66.5	62	37	114	134.0	44.5	96.8	22.0	2.3	HPFC632-66	420

Please add the **suffixes** below according to the material required

Material	Suffix surface and material	Example
Steel, zinc plated, Cr(VI)-free	CF	HPFC624-50CF
Stainless steel	SS	HPFC624-50SS



HPFC – Complete flange with metric thread holes incl. locking

ISO 6162-2

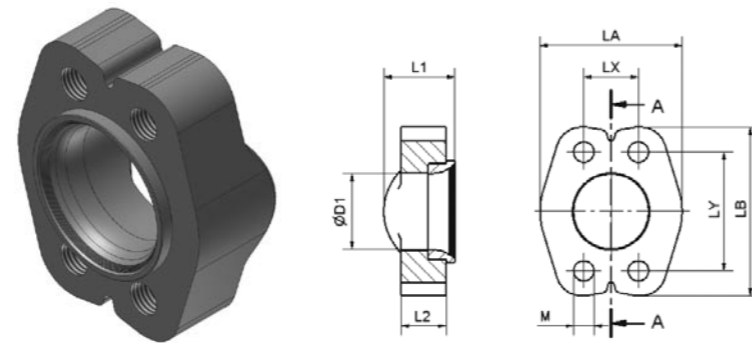

Size	Tube OD	D1	L1	L2	LA	LB	LX	LY	M	Weight (Steel) kg/1 piece	Order code	PN (bar)
3/4"	25	25.5	33	19	60	71.4	23.8	50.8	M10	0.5	HPFCM612-25	420
1"	30	35.5	39	24	70	81.0	27.8	57.2	M12	0.5	HPFCM616-30	420
1"	38	38.5	39	24	70	81.0	27.8	57.2	M12	0.6	HPFCM616-38	420
1 1/4"	38	38.5	44	27	78	96.0	31.8	66.6	M14	0.9	HPFCM620-38	420
1 1/4"	42	42.5	44	27	78	96.0	31.8	66.6	M14	0.9	HPFCM620-42	420
1 1/2"	50	50.5	48	30	96	113.0	36.5	79.3	M16	1.5	HPFCM624-50	420
2"	50	50.5	58	37	114	134.0	44.5	96.8	M20	2.5	HPFCM632-50	420
2"	60	60.5	62	37	114	134.0	44.5	96.8	M20	2.4	HPFCM632-60	420
2"	65	65.5	62	37	114	134.0	44.5	96.8	M20	2.3	HPFCM632-65	420
2"	66	66.5	62	37	114	134.0	44.5	96.8	M20	2.3	HPFCM632-66	420

Please add the **suffixes** below according to the material required

Material	Suffix surface and material	Example
Steel, zinc plated, Cr(VI)-free	CF	HPFCM624-50CF
Stainless steel	SS	HPFCM624-50SS



IPV - Insert with F37 profile seal

ISO 6162-2

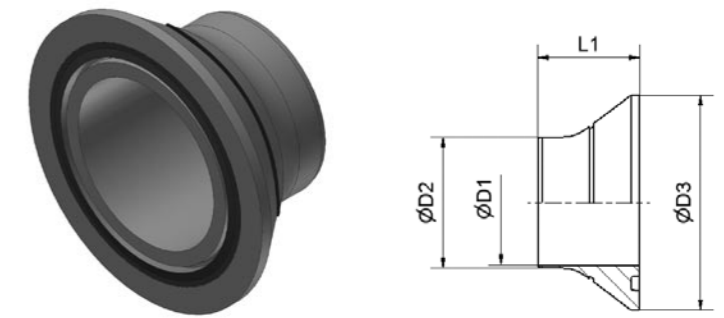

Size	Tube	D1	D2	D3	L1	Weight (Steel) kg/1 piece	O-Ring	F37 Seal	Insert (incl. seals)
3/4"	25x3.0	15.5	18.5	41.5	38	0.11	OR25.12X1.78	F37S12	IP612-25X3.0V
3/4"	25x4.0	13.5	16.5	41.5	39	0.11	OR23.52X1.78	F37S12	IP612-25X4.0V
1"	30x4.0	18.5	21.5	47.5	40	0.15	OR28.30X1.78	F37S16	IP616-30X4.0V
1"	30x5.0	16.5	19.5	47.5	41	0.16	OR26.70X1.78	F37S16	IP616-30X5.0V
1"	38x4.0	26.5	29.5	47.5	35	0.11	OR36.27X1.78	F37S16	IP616-38X4.0V
1"	38x6.0	22.5	25.5	47.5	37	0.13	OR29.87X1.78	F37S16	IP616-38X6.0V
1 1/4"	38x4.0	26.5	29.5	54.0	39	0.18	OR36.27X1.78	F37S20	IP620-38X4.0V
1 1/4"	38x5.0	24.5	27.5	54.0	40	0.19	OR36.27X1.78	F37S20	IP620-38X5.0V
1 1/4"	38x6.0	22.5	25.5	54.0	42	0.21	OR29.87X1.78	F37S20	IP620-38X6.0V
1 1/4"	42x5.0	28.5	31.5	54.0	38	0.17	OR37.82X1.78	F37S20	IP620-42X5.0V
1 1/2"	50x3.0	40.5	43.5	63.5	38	0.19	OR50.52X1.78	F37S24	IP624-50X3.0V
1 1/2"	50x5.0	36.5	39.5	63.5	40	0.21	OR50.52X1.78	F37S24	IP624-50X5.0V
1 1/2"	50x6.0	34.5	37.5	63.5	42	0.24	OR47.37X1.78	F37S24	IP624-50X6.0V
1 1/2"	50x8.0	30.5	33.5	63.5	42	0.27	OR44.17X1.78	F37S24	IP624-50X8.0V
2"	50x5.0	36.5	39.5	79.5	51	0.53	OR50.52X1.78	F37S32	IP632-50X5.0V
2"	50x6.0	34.5	37.5	79.5	53	0.58	OR50.52X1.78	F37S32	IP632-50X6.0V
2"	50x8.0	30.5	33.5	79.5	53	0.61	OR44.17X1.78	F37S32	IP632-50X8.0V
2"	60x8.0	40.5	43.5	79.5	47	0.49	OR56.87X1.78	F37S32	IP632-60X8.0V
2"	65x8.0	45.5	48.5	79.5	44	0.42	OR60.05X1.78	F37S32	IP632-65X8.0V
2"	66x8.5	45.5	48.5	79.5	44	0.42	OR60.05X1.78	F37S32	IP632-66X8.5V

Please add the **suffixes** below according to the material required

Material	Suffix surface and material	Example
Steel, phosphated	PHR	IP24-50X5.0VPHR
Steel, zinc plated, Cr(VI)-free	CF	IP24-50X5.0VCF
Stainless steel	SS	IP24-50X5.0VSS

IPF – Flat face insert

ISO 6162-2

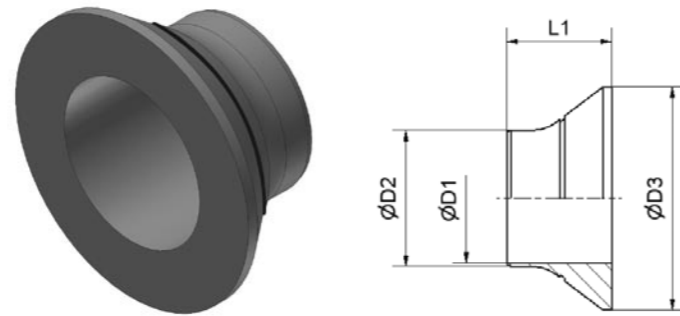

Size	Tube	D1	D2	D3	L1	Weight (Steel) kg/1 piece	O-ring	Insert (incl. O-ring)
3/4"	25x3.0	15.5	18.5	41.5	38	0.11	OR25.12X1.78	IP612-25X3.0F
3/4"	25x4.0	13.5	16.5	41.5	39	0.11	OR23.52X1.78	IP612-25X4.0F
1"	30x4.0	18.5	21.5	47.5	40	0.15	OR28.30X1.78	IP616-30X4.0F
1"	30x5.0	16.5	19.5	47.5	41	0.16	OR26.70X1.78	IP616-30X5.0F
1"	38x4.0	26.5	29.5	47.5	35	0.11	OR36.27X1.78	IP616-38X4.0F
1"	38x6.0	22.5	25.5	47.5	37	0.13	OR29.87X1.78	IP616-38X6.0F
1 1/4"	38x4.0	26.5	29.5	54.0	39	0.18	OR36.27X1.78	IP620-38X4.0F
1 1/4"	38x5.0	24.5	27.5	54.0	40	0.19	OR36.27X1.78	IP620-38X5.0F
1 1/4"	38x6.0	22.5	25.5	54.0	42	0.21	OR29.87X1.78	IP620-38X6.0F
1 1/4"	42x5.0	28.5	31.5	54.0	38	0.17	OR37.82X1.78	IP620-42X5.0F
1 1/2"	50x3.0	40.5	43.5	63.5	38	0.19	OR50.52X1.78	IP624-50X3.0F
1 1/2"	50x5.0	36.5	39.5	63.5	40	0.21	OR50.52X1.78	IP624-50X5.0F
1 1/2"	50x6.0	34.5	37.5	63.5	42	0.24	OR47.37X1.78	IP624-50X6.0F
1 1/2"	50x8.0	30.5	33.5	63.5	42	0.27	OR44.17X1.78	IP624-50X8.0F
2"	50x5.0	36.5	39.5	79.5	51	0.53	OR50.52X1.78	IP632-50X5.0F
2"	50x6.0	34.5	37.5	79.5	53	0.58	OR50.52X1.78	IP632-50X6.0F
2"	50x8.0	30.5	33.5	79.5	53	0.61	OR44.17X1.78	IP632-50X8.0F
2"	60x8.0	40.5	43.5	79.5	47	0.49	OR56.87X1.78	IP632-60X8.0F
2"	65x8.0	45.5	48.5	79.5	44	0.42	OR60.05X1.78	IP632-65X8.0F
2"	66x8.5	45.5	48.5	79.5	44	0.42	OR60.05X1.78	IP632-66X8.5F

Please add the **suffixes** below according to the material required

Material	Suffix surface and material	Example
Steel, phosphated	PHR	IP24-50X5.0FPHR
Steel, zinc plated, Cr(VI)-free	CF	IP24-50X5.0FCF
Stainless steel	SS	IP24-50X5.0FSS

F37 Profile seal

ISO 6162-2



Size	Description	O-ring	
		Order code	P5008
3/4"	F37S12		F37S12X
1"	F37S16		F37S16X
1 1/4"	F37S20		F37S20X
1 1/2"	F37S24		F37S24X
2"	F37S32		F37S32X

O-ring seal

ISO 6162-2



Size	Description	O-ring	
		NBR	Order code
3/4"	OR25X3.53	OR25X3.53X	OR25X3.53VITX
1"	OR32.92X3.53	OR32.92X3.53X	OR32.92X3.53VITX
1 1/4"	OR37.69X3.53	OR37.69X3.53X	OR37.69X3.53VITX
1 1/2"	OR47.22X3.53	OR47.22X3.53X	OR47.22X3.53VITX
2"	OR56.75X3.53	OR56.75X3.53X	OR56.75X3.53VITX

LB – Flange L-block

ISO 6162-2

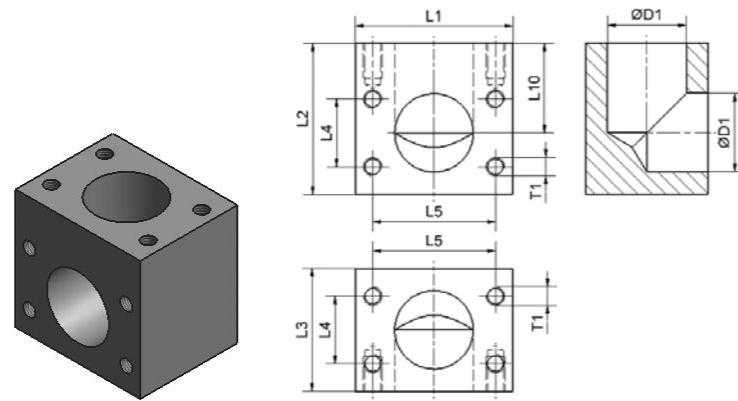

Size Inch	D1	L1	L2	L3	L10	L4	L5	T1	Weight (Steel) kg/1 piece	Order code
1"	25	80	80	65	54	27.8	57.2	M12	2.8	LB616CFX
1 1/4"	30	90	86	64	57	31.8	66.6	M14	3.2	LB620CFX
1 1/2"	38	100	100	74	66	36.5	79.3	M16	4.6	LB624CFX
2"	50	132	122	88	78	44.5	96.8	M20	8.8	LB632CFX

Please change **suffixes** according to material/surface required

Order code suffixes			
Material	Suffix surface and material	Example	Comments
Steel, zinc plated, Cr(VI)-free	CF	LB620CFX	only flange block
Steel, oil dipped	S	LB620SX	only flange block
Stainless steel	SS	LB620SSX	only flange block



LBR – Flange L-block reducer

ISO 6162-2

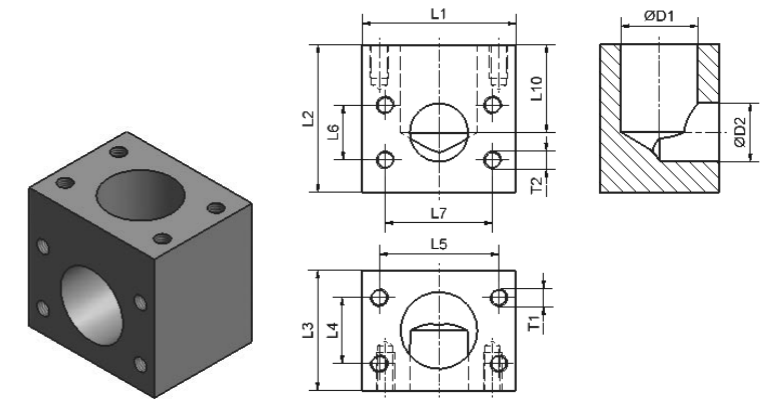

Size Inch	D1	D2	L1	L2	L3	L10	L4	L5	L6	L7	T1	T2	Weight (Steel) kg/1 piece	Order code
1 1/4 - 1"	30	25	90	86	64	57	31.8	66.6	27.8	57.2	M14	M12	3.3	LBR620-616CFX
1 1/2 - 1"	38	25	100	100	74	66	36.5	79.3	27.8	57.2	M16	M12	4.9	LBR624-616CFX
1 1/2 - 1 1/4"	38	30	100	100	74	66	36.5	79.3	31.8	66.6	M16	M14	4.8	LBR624-620CFX
2 - 1"	50	25	132	122	88	78	44.5	96.8	27.8	57.2	M20	M12	9.4	LBR632-616CFX
2 - 1 1/4"	50	30	132	122	88	78	44.5	96.8	31.8	66.6	M20	M14	9.3	LBR632-620CFX
2 - 1 1/2"	50	38	132	122	88	78	44.5	96.8	36.5	79.3	M20	M16	9.1	LBR632-624CFX

Please change **suffixes** according to material/surface required

Order code suffixes			
Material	Suffix surface and material	Example	Comments
Steel, zinc plated, Cr(VI)-free	CF	LBR620-616CFX	only flange block
Steel, oil dipped	S	LBR620-616SX	only flange block
Stainless steel	SS	LBR620-616SSX	only flange block

TB – Flange T-block

ISO 6162-2

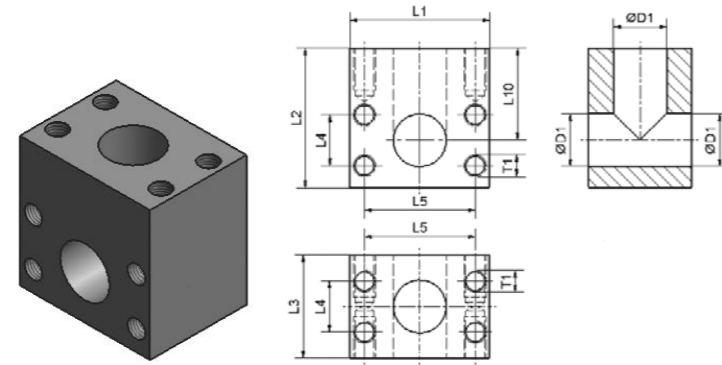

Size Inch	D1	L1	L2	L3	L10	L4	L5	T1	Weight (Steel) kg/1 piece	Order code
1"	25	80	80	65	54	27.8	57.2	M12	2.6	TB616TFX
1 1/4"	30	90	86	64	57	31.8	66.6	M14	3.0	TB620TFX
1 1/2"	38	100	100	74	66	36.5	79.3	M16	4.2	TB624TFX
2"	50	132	122	88	78	44.5	96.8	M20	8.0	TB632TFX

Please change **suffixes** according to material/surface required

Order code suffixes			
Material	Suffix surface and material	Example	Comments
Steel, zinc plated, Cr(VI)-free	CF	TB620CFX	only flange block
Steel, oil dipped	S	TB620SX	only flange block
Stainless steel	SS	TB620SSX	only flange block



TBR – Flange T-block reducer

ISO 6162-2

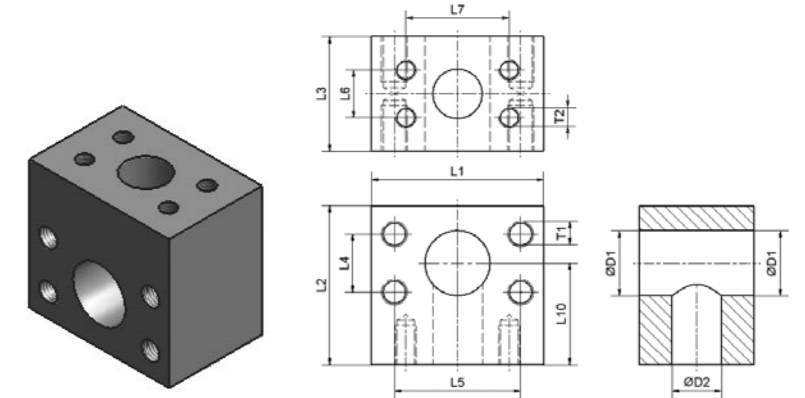

Size Inch	D1	D2	L1	L2	L3	L10	L4	L5	L6	L7	T1	T2	Weight (Steel) kg/1 piece	Order code
1 1/4 - 1 - 1 1/4"	30	25	90	86	64	57	31.8	66.6	27.8	57.2	M14	M12	3.1	TBR620-616-620CFX
1 1/2 - 1 1/4 - 1 1/2"	38	30	100	100	74	66	36.5	79.3	31.8	66.6	M16	M14	4.4	TBR624-620-624CFX
1 1/2 - 1 - 1 1/2"	38	25	100	100	74	66	36.5	79.3	27.8	57.2	M16	M12	4.6	TBR624-616-624CFX
2 - 1 1/2 - 2"	50	38	132	122	88	78	44.5	96.8	36.5	79.3	M20	M16	8.5	TBR632-624-632CFX
2 - 1 1/4 - 2"	50	30	132	122	88	78	44.5	96.8	31.8	66.6	M20	M14	8.8	TBR632-620-632CFX

	A	B	C
TBR620-616-620	1 1/4"	1"	1 1/4"
TBR620-620-616	1 1/4"	1 1/4"	1"
TBR616-620-620	1"	1 1/4"	1 1/4"

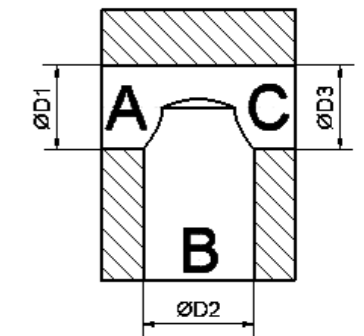

Please change **suffixes** according to material/surface required

Order code suffixes			
Material	Suffix surface and material	Example	Comments
Steel, zinc plated, Cr(VI)-free	CF	TBR620-616-620CFX	only flange block
Steel, oil dipped	S	TBR620-616-620SX	only flange block
Stainless steel	SS	TBR620-616-620SSX	only flange block

Bolts and nuts

ISO 6162-2

Size	Tube	Bolt ISO 4762 10.9 Tube/Tube (HPFC Flange with Through bore)		Nut ISO 4032	
		Description	Order code	Description	Order code
3/4"	25x3.0	M10x90	ZYLS10X90109X	M10	ISO4032-M-10-10
3/4"	25x4.0	M10x90	ZYLS10X90109X	M10	ISO4032-M-10-10
1"	30x4.0	M12x110	ZYLS12X110109X	M12	ISO4032-M-12-10
1"	30x5.0	M12x110	ZYLS12X110109X	M12	ISO4032-M-12-10
1"	38x4.0	M12x110	ZYLS12X110109X	M12	ISO4032-M-12-10
1"	38x6.0	M12x110	ZYLS12X110109X	M12	ISO4032-M-12-10
1 1/4"	38x4.0	M14x120	ZYLS14X120109X	M14	ISO4032-M-14-10
1 1/4"	38x5.0	M14x120	ZYLS14X120109X	M14	ISO4032-M-14-10
1 1/4"	38x6.0	M14x120	ZYLS14X120109X	M14	ISO4032-M-14-10
1 1/4"	42x5.0	M14x120	ZYLS14X120109X	M14	ISO4032-M-14-10
1 1/2"	50x3.0	M16x150	ZYLS16X150109X	M16	ISO4032-M-16-10
1 1/2"	50x5.0	M16x150	ZYLS16X150109X	M16	ISO4032-M-16-10
1 1/2"	50x6.0	M16x150	ZYLS16X150109X	M16	ISO4032-M-16-10
1 1/2"	50x8.0	M16x150	ZYLS16X150109X	M16	ISO4032-M-16-10
2"	50x5.0	M20x160	ZYLS20X160109X	M20	ISO4032-M-20-10
2"	50x6.0	M20x160	ZYLS20X160109X	M20	ISO4032-M-20-10
2"	60x8.0	M20x160	ZYLS20X160109X	M20	ISO4032-M-20-10
2"	65x8.0	M20x160	ZYLS20X160109X	M20	ISO4032-M-20-10
2"	66x8.5	M20x160	ZYLS20X160109X	M20	ISO4032-M-20-10

Size	Tube	Bolt ISO 4762 10.9 Tube/Port		Tube/Tube (HPFCM Flange with Thread bore)	
		Description	Order code	Description	Order code
3/4"	25x3.0	M10x50	ZYLS10X50109X	M10x70	ZYLS10X70109X
3/4"	25x4.0	M10x50	ZYLS10X50109X	M10x70	ZYLS10X70109X
1"	30x4.0	M12x60	ZYLS12X60109X	M10x90	ZYLS12X90109X
1"	30x5.0	M12x60	ZYLS12X60109X	M10x90	ZYLS12X90109X
1"	38x4.0	M12x60	ZYLS12X60109X	M12x90	ZYLS12X90109X
1"	38x6.0	M12x60	ZYLS12X60109X	M12x90	ZYLS12X90109X
1 1/4"	38x4.0	M14x70	ZYLS14X70109X	M14x100	ZYLS14X100109X
1 1/4"	38x5.0	M14x70	ZYLS14X70109X	M14x100	ZYLS14X100109X
1 1/4"	38x6.0	M14x70	ZYLS14X70109X	M14x100	ZYLS14X100109X
1 1/4"	42x5.0	M14x70	ZYLS14X70109X	M14x100	ZYLS14X100109X
1 1/2"	50x3.0	M16x80	ZYLS16X80109X	M16x130	ZYLS16X130109X
1 1/2"	50x5.0	M16x80	ZYLS16X80109X	M16x130	ZYLS16X130109X
1 1/2"	50x6.0	M16x80	ZYLS16X80109X	M16x130	ZYLS16X130109X
1 1/2"	50x8.0	M16x80	ZYLS16X80109X	M16x130	ZYLS16X130109X
2"	50x5.0	M20x100	ZYLS20X100109X	M20x140	ZYLS20X140109X
2"	50x6.0	M20x100	ZYLS20X100109X	M20x140	ZYLS20X140109X
2"	60x8.0	M20x100	ZYLS20X100109X	M20x140	ZYLS20X140109X
2"	65x8.0	M20x100	ZYLS20X100109X	M20x140	ZYLS20X140109X
2"	66x8.5	M20x100	ZYLS20X100109X	M20x140	ZYLS20X140109X

Check torque details (see page 18)

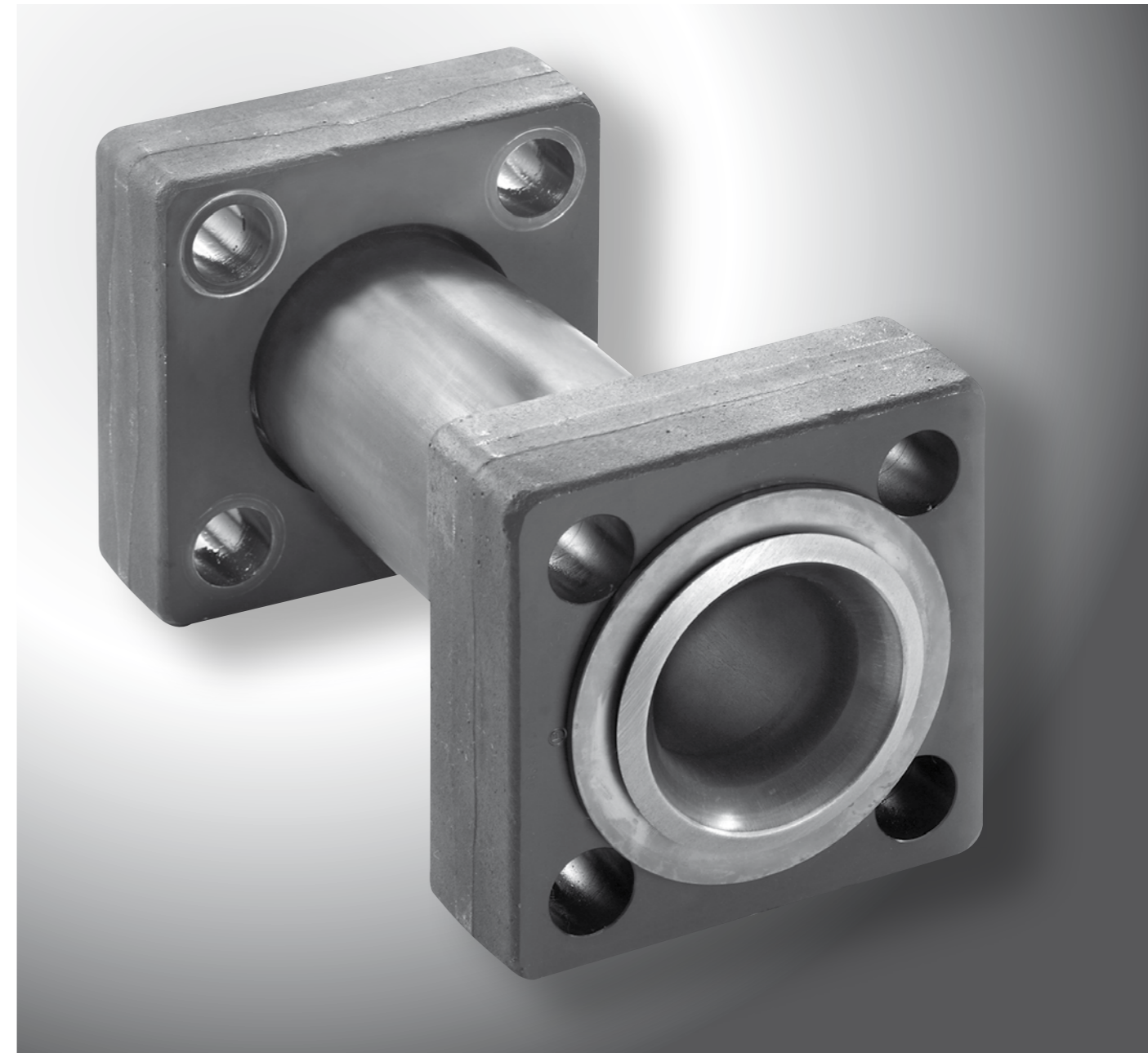

HPF – ISO 6164 Square flange

HPF – Tube-to-tube connection

Overview Tube to tube connection

Example 38x4.0 in 1“: 1x Flange connection complete with profile seal HPF416-38X4.0-V
 1x Flange connection complete flat version HPF416-38X4.0-F
 4x Bolts M10x110
 4x Nuts M10-10

**Flange connection 1
 ISO 6164 with F37 profile seal**

Size	Tube	Flange connection complete	Flange connection consists of				Bolts 10.9 ISO 4762 4x	Nut ISO 4032 4x
			Insert 1x	Flange incl. locking 1x	Flange seal F37 sealing ring 1x	Tube seal O-ring 1x		
3/4"	25x3.0	HPF412-25X3.0-V	IP612-25X3.0V	HPFC412-25	F37S12	OR25.12X1.78	M8x100	M8-10
3/4"	25x4.0	HPF412-25X4.0-V	IP612-25X4.0V	HPFC412-25	F37S12	OR23.52X1.78	M8x100	M8-10
1"	30x4.0	HPF416-30X4.0-V	IP616-30X4.0V	HPFC416-30	F37S16	OR28.30X1.78	M10x110	M10-10
1"	30x5.0	HPF416-30X5.0-V	IP616-30X5.0V	HPFC416-30	F37S16	OR26.70X1.78	M10x110	M10-10
1"	38x4.0	HPF416-38X4.0-V	IP616-38X4.0V	HPFC416-38	F37S16	OR36.27X1.78	M10x110	M10-10
1"	38x6.0	HPF416-38X6.0-V	IP616-38X6.0V	HPFC416-38	F37S16	OR29.87X1.78	M10x110	M10-10
1 1/4"	38x4.0	HPF420-38X4.0-V	IP620-38X4.0V	HPFC420-38	F37S20	OR36.27X1.78	M12x120	M12-10
1 1/4"	38x5.0	HPF420-38X5.0-V	IP620-38X5.0V	HPFC420-38	F37S20	OR36.27X1.78	M12x120	M12-10
1 1/4"	38x6.0	HPF420-38X6.0-V	IP620-38X6.0V	HPFC420-38	F37S20	OR29.87X1.78	M12x120	M12-10
1 1/4"	42x5.0	HPF420-42X5.0-V	IP620-42X5.0V	HPFC420-42	F37S20	OR37.82X1.78	M12x120	M12-10
1 1/2"	50x3.0	HPF424-50X3.0-V	IP624-50X3.0V	HPFC424-50	F37S24	OR50.52X1.78	M16x170	M16-10
1 1/2"	50x5.0	HPF424-50X5.0-V	IP624-50X5.0V	HPFC424-50	F37S24	OR50.52X1.78	M16x170	M16-10
1 1/2"	50x6.0	HPF424-50X6.0-V	IP624-50X6.0V	HPFC424-50	F37S24	OR47.37X1.78	M16x170	M16-10
1 1/2"	50x8.0	HPF424-50X8.0-V	IP624-50X8.0V	HPFC424-50	F37S24	OR44.17X1.78	M16x170	M16-10
2"	50x5.0	HPF432-50X5.0-V	IP432-50X5.0V	HPFC432-50	F37S32	OR50.52X1.78	M16x170	M16-10
2"	50x6.0	HPF432-50X6.0-V	IP432-50X6.0V	HPFC432-50	F37S32	OR50.52X1.78	M16x170	M16-10
2"	50x8.0	HPF432-50X8.0-V	IP432-50X8.0V	HPFC432-50	F37S32	OR44.17X1.78	M16x170	M16-10
2 1/2"	60x8.0	HPF440-60X8.0-V	IP440-60X8.0V	HPFC440-60	F37S440	OR56.87X1.78	M20x190	M20-10
2 1/2"	65x8.0	HPF440-65X8.0-V	IP440-65X8.0V	HPFC440-65	F37S440	OR60.05X1.78	M20x190	M20-10
2 1/2"	66x8.5	HPF440-66X8.5-V	IP440-66X8.5V	HPFC440-66	F37S440	OR60.05X1.78	M20x190	M20-10
2 1/2"	75x12.5	HPF440-75X12.5-V	IP440-75X12.5V	HPFC440-75	F37S440	OR60.05X1.78	M20x190	M20-10
3"	80x3.0	HPF448-80X3.0-V	IP448-80X3.0V	HPFC448-80	F37S448	OR82.27X1.78	M24x200	M24-10
3"	80x8.0	HPF448-80X8.0-V	IP448-80X8.0V	HPFC448-80	F37S448	OR72.75X1.78	M24x200	M24-10
3"	80x10.0	HPF448-80X10.0-V	IP448-80X10.0V	HPFC448-80	F37S448	OR69.57X1.78	M24x200	M24-10
3"	88x14.0	HPF448-88X14.0-V	IP448-88X14.0V	HPFC448-88	F37S448	OR72.75X1.78	M24x200	M24-10

Flange connection 2 see next page.

HPF – Tube-to-tube connection (Continued)

Overview tube-to-tube connection, flat face

Example 38x4.0 in 1“: 1x Flange connection complete with profile seal HPF416-38X4.0-V
 1x Flange connection complete flat face HPF416-38X4.0-F
 4x Bolts M10x110
 4x Nuts M10-10

**Flange connection 2
 ISO 6164 flat**

Size	Tube	Flange connection complete	Flange connection consists of		
			Insert 1x	Flange incl. locking 1x	Tube seal O-ring 1x
3/4"	25x3.0	HPF412-25X3.0-F	IP612-25X3.0F	HPFC412-25	OR25.12X1.78
3/4"	25x4.0	HPF412-25X4.0-F	IP612-25X4.0F	HPFC412-25	OR23.52X1.78
1"	30x4.0	HPF416-30X4.0-F	IP616-30X4.0F	HPFC416-30	OR28.30X1.78
1"	30x5.0	HPF416-30X5.0-F	IP616-30X5.0F	HPFC416-30	OR26.70X1.78
1"	38x4.0	HPF416-38X4.0-F	IP616-38X4.0F	HPFC416-38	OR36.27X1.78
1"	38x6.0	HPF416-38X6.0-F	IP616-38X6.0F	HPFC416-38	OR29.87X1.78
1 1/4"	38x4.0	HPF420-38X4.0-F	IP620-38X4.0F	HPFC420-38	OR36.27X1.78
1 1/4"	38x5.0	HPF420-38X5.0-F	IP620-38X5.0F	HPFC420-38	OR36.27X1.78
1 1/4"	38x6.0	HPF420-38X6.0-F	IP620-38X6.0F	HPFC420-38	OR29.87X1.78
1 1/4"	42x5.0	HPF420-42X5.0-F	IP620-42X5.0F	HPFC420-42	OR37.82X1.78
1 1/2"	50x3.0	HPF424-50X3.0-F	IP624-50X3.0F	HPFC424-50	OR50.52X1.78
1 1/2"	50x5.0	HPF424-50X5.0-F	IP624-50X5.0F	HPFC424-50	OR50.52X1.78
1 1/2"	50x6.0	HPF424-50X6.0-F	IP624-50X6.0F	HPFC424-50	OR47.37X1.78
1 1/2"	50x8.0	HPF424-50X8.0-F	IP624-50X8.0F	HPFC424-50	OR44.17X1.78
2"	50x5.0	HPF432-50X5.0-F	IP632-50X5.0F	HPFC432-50	OR50.52X1.78
2"	50x6.0	HPF432-50X6.0-F	IP632-50X6.0F	HPFC432-50	OR50.52X1.78
2"	50x8.0	HPF432-50X8.0-F	IP632-50X8.0F	HPFC432-50	OR44.17X1.78
2 1/2"	60x8.0	HPF432-60X8.0-F	IP432-60X8.0F	HPFC432-60	OR56.87X1.78
2 1/2"	65x8.0	HPF432-65X8.0-F	IP432-65X8.0F	HPFC432-65	OR60.05X1.78
2 1/2"	66x8.5	HPF432-66X8.5-F	IP432-66X8.5F	HPFC432-66	OR60.05X1.78
2 1/2"	75x12.5	HPF440-75X12.5-F	IP440-75X12.5F	HPFC440-75	OR60.05X1.78
3"	80x3.0	HPF448-80X3.0-F	IP448-80X3.0F	HPFC448-80	OR82.27X1.78
3"	80x8.0	HPF448-80X8.0-F	IP448-80X8.0F	HPFC448-80	OR72.75X1.78
3"	80x10.0	HPF448-80X10.0-F	IP448-80X10.0F	HPFC448-80	OR69.57X1.78
3"	88x14.0	HPF448-88X14.0-F	IP448-88X14.0F	HPFC448-88	OR72.75X1.78



HPF – Tube-to-port connection

Overview tube-to-port connection with profile seal

Example 38x4.0 in 1": 1x Flange connection complete with profile seal HPF616-38X4.0-V
4x Bolts M10x55

ISO 6164 Flange with F37 profile seal:

Size	Tube	Flange connection complete	Flange connection consists of				Bolts 10.9 ISO 4762 4x
			Insert 1x	Flange incl. lockring 1x	Flange seal F37 lockring 1x	Tube seal O-ring 1x	
3/4"	25x3.0	HPF412-25X3.0-V	IP612-25X3.0V	HPFC412-25	F37S12	OR25.12X1.78	M8x50
3/4"	25x4.0	HPF412-25X4.0-V	IP612-25X4.0V	HPFC412-25	F37S12	OR23.52X1.78	M8x50
1"	30x4.0	HPF416-30X4.0-V	IP616-30X4.0V	HPFC416-30	F37S16	OR28.30X1.78	M10x55
1"	30x5.0	HPF416-30X5.0-V	IP616-30X5.0V	HPFC416-30	F37S16	OR26.70X1.78	M10x55
1"	38x4.0	HPF416-38X4.0-V	IP616-38X4.0V	HPFC416-38	F37S16	OR36.27X1.78	M10x55
1"	38x6.0	HPF416-38X6.0-V	IP616-38X6.0V	HPFC416-38	F37S16	OR29.87X1.78	M10x55
1 1/4"	38x4.0	HPF420-38X4.0-V	IP620-38X4.0V	HPFC420-38	F37S20	OR36.27X1.78	M12x70
1 1/4"	38x5.0	HPF420-38X5.0-V	IP620-38X5.0V	HPFC420-38	F37S20	OR36.27X1.78	M12x70
1 1/4"	38x6.0	HPF420-38X6.0-V	IP620-38X6.0V	HPFC420-38	F37S20	OR29.87X1.78	M12x70
1 1/4"	42x5.0	HPF420-42X5.0-V	IP620-42X5.0V	HPFC420-42	F37S20	OR37.82X1.78	M12x70
1 1/2"	50x3.0	HPF424-50X3.0-V	IP624-50X3.0V	HPFC424-50	F37S24	OR50.52X1.78	M16x90
1 1/2"	50x5.0	HPF424-50X5.0-V	IP624-50X5.0V	HPFC424-50	F37S24	OR50.52X1.78	M16x90
1 1/2"	50x6.0	HPF424-50X6.0-V	IP624-50X6.0V	HPFC424-50	F37S24	OR47.37X1.78	M16x90
1 1/2"	50x8.0	HPF424-50X8.0-V	IP624-50X8.0V	HPFC424-50	F37S24	OR44.17X1.78	M16x90
2"	50x5.0	HPF432-50X5.0-V	IP432-50X5.0V	HPFC432-50	F37S32	OR50.52X1.78	M16x90
2"	50x6.0	HPF432-50X6.0-V	IP432-50X6.0V	HPFC432-50	F37S32	OR50.52X1.78	M16x90
2"	50x8.0	HPF432-50X8.0-V	IP432-50X8.0V	HPFC432-50	F37S32	OR44.17X1.78	M16x90
2 1/2"	60x8.0	HPF440-60X8.0-V	IP440-60X8.0V	HPFC440-60	F37S440	OR56.87X1.78	M20x100
2 1/2"	65x8.0	HPF440-65X8.0-V	IP440-65X8.0V	HPFC440-65	F37S440	OR60.05X1.78	M20x100
2 1/2"	66x8.5	HPF440-66X8.5-V	IP440-66X8.5V	HPFC440-66	F37S440	OR60.05X1.78	M20x100
2 1/2"	75x12.5	HPF440-75X12.5-V	IP440-75X12.5V	HPFC440-75	F37S440	OR60.05X1.78	M20x100
3"	80x3.0	HPF448-80X3.0-V	IP448-80X3.0V	HPFC448-80	F37S448	OR82.27X1.78	M24x110
3"	80x8.0	HPF448-80X8.0-V	IP448-80X8.0V	HPFC448-80	F37S448	OR72.75X1.78	M24x110
3"	80x10.0	HPF448-80X10.0-V	IP448-80X10.0V	HPFC448-80	F37S448	OR69.57X1.78	M24x110
3"	88x14.0	HPF448-88X14.0-V	IP448-88X14.0V	HPFC448-88	F37S448	OR72.75X1.78	M24x110

HPF – Tube-to-port connection

Overview tube-to-port connecton, flat face

Example 38x4.0 in 1": 1x Flange connection complete, flat face HPF616-38X4.0-F
4x Bolts M10x55

ISO 6164 Flange flat

Size	Tube	Flange complete	Flange connection consists of			Bolts 10.9 ISO 4762 4x
			Inner part 1x	Flange incl. lockring 1x	tube seal O-ring 1x	
3/4"	25x3.0	HPF412-25X3.0-F	IP612-25X3.0F	HPFC412-25	OR25.12X1.78	M8x50
3/4"	25x4.0	HPF412-25X4.0-F	IP612-25X4.0F	HPFC412-25	OR23.52X1.78	M8x50
1"	30x4.0	HPF416-30X4.0-F	IP616-30X4.0F	HPFC416-30	OR28.30X1.78	M10x55
1"	30x5.0	HPF416-30X5.0-F	IP616-30X5.0F	HPFC416-30	OR26.70X1.78	M10x55
1"	38x4.0	HPF416-38X4.0-F	IP616-38X4.0F	HPFC416-38	OR36.27X1.78	M10x55
1"	38x6.0	HPF416-38X6.0-F	IP616-38X6.0F	HPFC416-38	OR29.87X1.78	M10x55
1 1/4"	38x4.0	HPF420-38X4.0-F	IP620-38X4.0F	HPFC420-38	OR36.27X1.78	M12x70
1 1/4"	38x5.0	HPF420-38X5.0-F	IP620-38X5.0F	HPFC420-38	OR36.27X1.78	M12x70
1 1/4"	38x6.0	HPF420-38X6.0-F	IP620-38X6.0F	HPFC420-38	OR29.87X1.78	M12x70
1 1/4"	42x5.0	HPF420-42X5.0-F	IP620-42X5.0F	HPFC420-42	OR37.82X1.78	M12x70
1 1/2"	50x3.0	HPF424-50X3.0-F	IP624-50X3.0F	HPFC424-50	OR50.52X1.78	M16x90
1 1/2"	50x5.0	HPF424-50X5.0-F	IP624-50X5.0F	HPFC424-50	OR50.52X1.78	M16x90
1 1/2"	50x6.0	HPF424-50X6.0-F	IP624-50X6.0F	HPFC424-50	OR47.37X1.78	M16x90
1 1/2"	50x8.0	HPF424-50X8.0-F	IP624-50X8.0F	HPFC424-50	OR44.17X1.78	M16x90
2"	50x5.0	HPF432-50X5.0-F	IP432-50X5.0F	HPFC432-50	OR50.52X1.78	M16x90
2"	50x6.0	HPF432-50X6.0-F	IP432-50X6.0F	HPFC432-50	OR50.52X1.78	M16x90
2"	50x8.0	HPF432-50X8.0-F	IP432-50X8.0F	HPFC432-50	OR44.17X1.78	M16x90
2 1/2"	60x8.0	HPF440-60X8.0-F	IP440-60X8.0F	HPFC440-60	OR56.87X1.78	M20x100
2 1/2"	65x8.0	HPF440-65X8.0-F	IP440-65X8.0F	HPFC440-65	OR60.05X1.78	M20x100
2 1/2"	66x8.5	HPF440-66X8.5-F	IP440-66X8.5F	HPFC440-66	OR60.05X1.78	M20x100
2 1/2"	75x12.5	HPF440-75X12.5-F	IP440-75X12.5F	HPFC440-75	OR60.05X1.78	M20x100
3"	80x3.0	HPF448-80X3.0-F	IP448-80X3.0F	HPFC448-80	OR82.27X1.78	M24x110
3"	80x8.0	HPF448-80X8.0-F	IP448-80X8.0F	HPFC448-80	OR72.75X1.78	M24x110
3"	80x10.0	HPF448-80X10.0-F	IP448-80X10.0F	HPFC448-80	OR69.57X1.78	M24x110
3"	88x14.0	HPF448-88X14.0-F	IP448-88X14.0F	HPFC448-88	OR72.75X1.78	M24x110



HPFC – Complete flange with metric thread holes incl. locking

ISO 6164

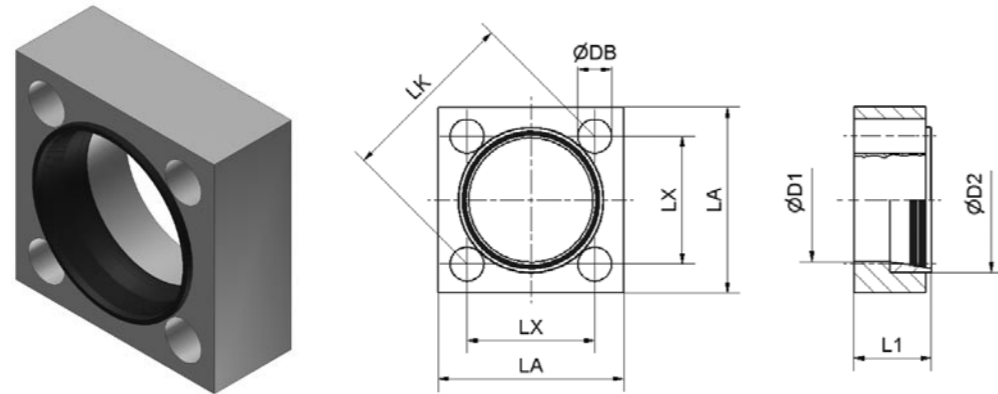

Size	Tube OD	LK	D1	D2	L1	LA	LX	DB	Weight (Steel) kg/1 piece	Order code	PN (bar)
3/4"	25	50	32.5	42.1	22.0	50	35.4	9.0	0.25	HPFC412-25	400
1"	30	62	38.9	48.4	33.0	65	43.8	11.0	0.45	HPFC416-30	400
1"	38	62	38.9	48.4	32.0	65	43.8	11.0	0.40	HPFC416-38	400
1 1/4"	38	73	44.6	54.8	36.5	75	51.6	13.5	0.60	HPFC420-38	400
1 1/4"	42	73	44.6	54.8	37.5	75	51.6	13.5	0.56	HPFC420-42	400
1 1/2"	50	85	51.6	64.3	42.5	90	60.1	17.5	0.85	HPFC424-50	400
2"	50	98	67.6	80.2	40.0	100	69.3	17.5	1.55	HPFC432-50	400
2 1/2"	60	118	80.5	95.0	50.0	120	83.4	22.0	2.80	HPFC440-60	400
2 1/2"	65	118	80.5	95.0	50.0	120	83.4	22.0	2.50	HPFC440-65	400
2 1/2"	66	118	80.5	95.0	50.0	120	83.4	22.0	2.40	HPFC440-66	400
2 1/2"	75	118	80.5	95.0	55.0	120	83.4	22.0	2.50	HPFC440-75	400
3"	80	145	90.5	111.0	56.0	150	102.5	26.0	3.60	HPFC448-80	400
3"	88	145	90.5	111.0	56.0	150	102.5	26.0	3.40	HPFC448-88	400

Please add the **suffixes** below according to the material required

Material	Suffix surface and material	Example
Steel, phosphated	PHR	HPFC424-50PHR
Stainless steel	SS	HPFC424-50SS

IPV – Insert with F37 profile seal

ISO 6164



Size	Tube	D1	D2	D3	L1	Weight (Steel) kg/1 piece	O-Ring	F37 Seal	Insert (incl. seals)
3/4"	25x3.0	15.5	18.5	41.5	38	0.11	OR25.12X1.78	F37S12	IP612-25X3.0V
3/4"	25x4.0	13.5	16.5	41.5	39	0.11	OR23.52X1.78	F37S12	IP612-25X4.0V
1"	30x4.0	18.5	21.5	47.5	40	0.15	OR28.30X1.78	F37S16	IP616-30X4.0V
1"	30x5.0	16.5	19.5	47.5	41	0.16	OR26.70X1.78	F37S16	IP616-30X5.0V
1"	38x4.0	26.5	29.5	47.5	35	0.11	OR36.27X1.78	F37S16	IP616-38X4.0V
1"	38x6.0	22.5	25.5	47.5	37	0.13	OR29.87X1.78	F37S16	IP616-38X6.0V
1 1/4"	38x4.0	26.5	29.5	54.0	39	0.18	OR36.27X1.78	F37S20	IP620-38X4.0V
1 1/4"	38x5.0	24.5	27.5	54.0	40	0.19	OR36.27X1.78	F37S20	IP620-38X5.0V
1 1/4"	38x6.0	22.5	25.5	54.0	42	0.21	OR29.87X1.78	F37S20	IP620-38X6.0V
1 1/4"	42x5.0	28.5	31.5	54.0	38	0.17	OR37.82X1.78	F37S20	IP620-42X5.0V
1 1/2"	50x3.0	40.5	43.5	63.5	38	0.19	OR50.52X1.78	F37S24	IP624-50X3.0V
1 1/2"	50x5.0	36.5	39.5	63.5	40	0.21	OR50.52X1.78	F37S24	IP624-50X5.0V
1 1/2"	50x6.0	34.5	37.5	63.5	42	0.24	OR47.37X1.78	F37S24	IP624-50X6.0V
1 1/2"	50x8.0	30.5	33.5	63.5	42	0.27	OR44.17X1.78	F37S24	IP624-50X8.0V
2"	50x5.0	36.5	39.5	79.5	51	0.50	OR50.52X1.78	F37S32	IP432-50X5.0V
2"	50x6.0	34.5	37.5	79.5	53	0.56	OR50.52X1.78	F37S32	IP432-50X6.0V
2"	50x8.0	30.5	33.5	79.5	53	0.59	OR44.17X1.78	F37S32	IP432-50X8.0V
2 1/2"	60x8.0	40.5	43.5	94.0	56	0.86	OR56.87X1.78	F37S440	IP440-60X8.0V
2 1/2"	65x8.0	45.5	48.5	94.0	53	0.77	OR60.05X1.78	F37S440	IP440-65X8.0V
2 1/2"	66x8.5	45.5	48.5	94.0	53	0.77	OR60.05X1.78	F37S440	IP440-66X8.5V
2 1/2"	75x12.5	46.5	49.5	94.0	53	0.72	OR60.05X1.78	F37S440	IP440-75X12.5V
3"	80x3.0	59.0	73.5	104.0	43	0.73	OR82.27X1.78	F37S448	IP448-80X3.0V
3"	80x8.0	60.5	63.5	104.0	49	0.75	OR72.75X1.78	F37S448	IP448-80X8.0V
3"	80x10.0	56.5	59.5	104.0	52	0.86	OR69.57X1.78	F37S448	IP448-80X10.0V
3"	88x14.0	56.5	59.5	104.0	52	0.86	OR72.75X1.78	F37S448	IP448-88X14.0V

Please add the **suffixes** below according to the material required

Material	Suffix surface and material	Example
Steel, phosphated	PHR	IP432-50X5.0VPHR
Steel, zinc plated, Cr(VI)-free	CF	IP432-50X5.0VCF
Stainless steel	SS	IP432-50X5.0VSS

IPF – Flat face insert

ISO 6164

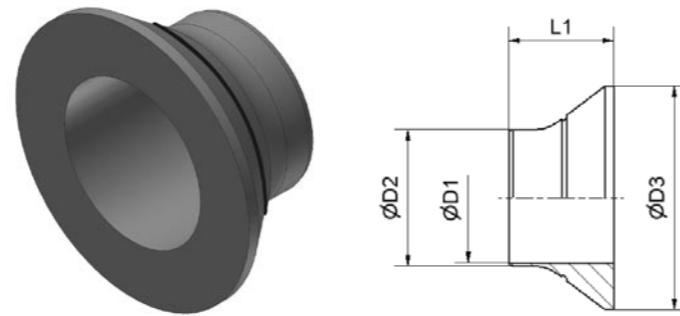

Size	Tube	D1	D2	D3	L1	Weight (Steel) kg/1 piece	O-ring	Insert (incl. O-ring)
3/4"	25x3.0	15.5	18.5	41.5	38	0.11	OR25.12X1.78	IP612-25X3.0F
3/4"	25x4.0	13.5	16.5	41.5	39	0.11	OR23.52X1.78	IP612-25X4.0F
1"	30x4.0	18.5	21.5	47.5	40	0.15	OR28.30X1.78	IP616-30X4.0F
1"	30x5.0	16.5	19.5	47.5	41	0.16	OR26.70X1.78	IP616-30X5.0F
1"	38x4.0	26.5	29.5	47.5	35	0.11	OR36.27X1.78	IP616-38X4.0F
1"	38x6.0	22.5	25.5	47.5	37	0.13	OR29.87X1.78	IP616-38X6.0F
1 1/4"	38x4.0	26.5	29.5	54.0	39	0.18	OR36.27X1.78	IP620-38X4.0F
1 1/4"	38x5.0	24.5	27.5	54.0	40	0.19	OR36.27X1.78	IP620-38X5.0F
1 1/4"	38x6.0	22.5	25.5	54.0	42	0.21	OR29.87X1.78	IP620-38X6.0F
1 1/4"	42x5.0	28.5	31.5	54.0	38	0.17	OR37.82X1.78	IP620-42X5.0F
1 1/2"	50x3.0	40.5	43.5	63.5	38	0.19	OR50.52X1.78	IP624-50X3.0F
1 1/2"	50x5.0	36.5	39.5	63.5	40	0.21	OR50.52X1.78	IP624-50X5.0F
1 1/2"	50x6.0	34.5	37.5	63.5	42	0.24	OR47.37X1.78	IP624-50X6.0F
1 1/2"	50x8.0	30.5	33.5	63.5	42	0.27	OR44.17X1.78	IP624-50X8.0F
2"	50x5.0	36.5	39.5	79.5	51	0.50	OR50.52X1.78	IP432-50X5.0F
2"	50x6.0	34.5	37.5	79.5	53	0.56	OR50.52X1.78	IP432-50X6.0F
2"	50x8.0	30.5	33.5	79.5	53	0.59	OR44.17X1.78	IP432-50X8.0F
2 1/2"	60x8.0	40.5	43.5	94.0	56	0.86	OR56.87X1.78	IP440-60X8.0F
2 1/2"	65x8.0	45.5	48.5	94.0	53	0.77	OR60.05X1.78	IP440-65X8.0F
2 1/2"	66x8.5	45.5	48.5	94.0	53	0.77	OR60.05X1.78	IP440-66X8.5F
2 1/2"	75x12.5	46.5	49.5	94.0	53	0.72	OR60.05X1.78	IP440-75X12.5F
3"	80x3.0	59.0	73.5	104.0	43	0.73	OR82.27X1.78	IP448-80X3.0F
3"	80x8.0	60.5	63.5	104.0	49	0.75	OR72.75X1.78	IP448-80X8.0F
3"	80x10.0	56.5	59.5	104.0	52	0.86	OR69.57X1.78	IP448-80X10.0F
3"	88x14.0	56.5	59.5	104.0	52	0.86	OR72.75X1.78	IP448-88X14.0F

Please add the suffixes below according to the material required

Material	Suffix surface and material	Example
Steel, phosphated	PHR	IP432-50X5.0FPHR
Steel, zinc plated, Cr(VI)-free	CF	IP432-50X5.0FCF
Stainless steel	SS	IP432-50X5.0FSS



F37 Profile seal

ISO 6164



Size	Description	O-Ring	
		Order code P5008	
3/4"	F37S12		F37S12X
1"	F37S16		F37S16X
1 1/4"	F37S20		F37S20X
1 1/2"	F37S24		F37S24X
2"	F37S32		F37S432X
2 1/2"	F37S440		F37S440X
3"	F37S448		F37S448X

O-ring seal

ISO 6164



Size	Description	O-Ring	
		NBR	Order code FKM
3/4"	OR25X3.53	OR25X3.53X	OR25X3.53VITX
1"	OR32.92X3.53	OR32.92X3.53X	OR32.92X3.53VITX
1 1/4"	OR37.69X3.53	OR37.69X3.53X	OR37.69X3.53VITX
1 1/2"	OR47.22X3.53	OR47.22X3.53X	OR47.22X3.53VITX
2"	OR56.75X3.53	OR56.75X3.53X	OR56.75X3.53VITX
2 1/2"	OR69.22X5.33	OR69.22X5.33X	OR69.22X5.33VITX
3"	OR75.57X5.33	OR75.57X5.33X	OR75.57X5.33VITX

LB – Flange L-block

ISO 6164

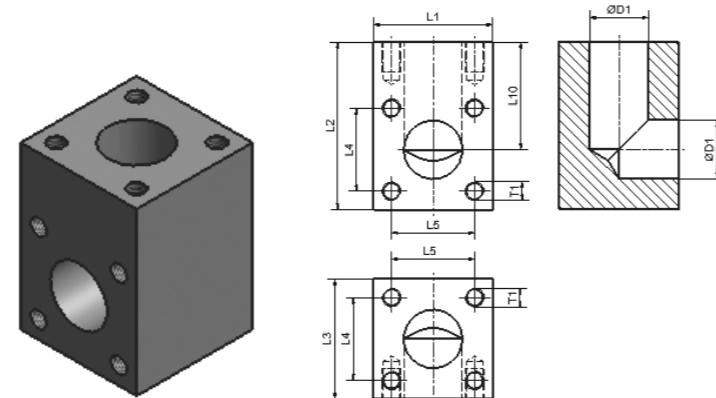

Size Inch	D1	L1	L2	L3	L10	L4	L5	T1	Weight (Steel) kg/1 piece	Order code
2"	49	100	140	100	90	69.3	69.3	M16	8.72	LB432CFX
2 1/2"	60	120	160	120	100	83.4	83.4	M20	14.10	LB440CFX
3"	73	150	200	150	125	102.5	102.5	M24	28.10	LB448CFX
4"	85	180	240	180	150	123.7	123.7	M30	48.80	LB464CFX

TB – Flange T-block

ISO 6164

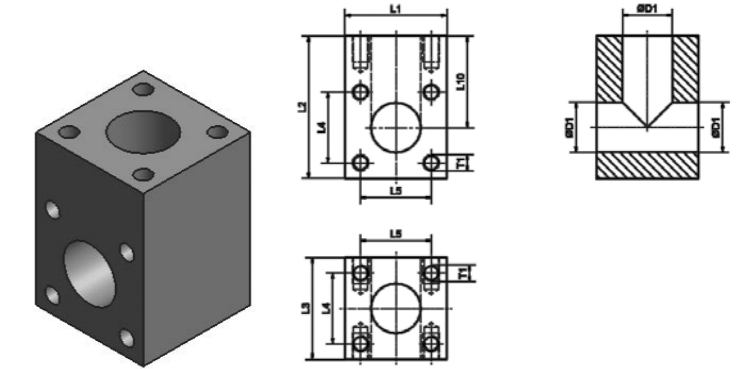

Size Inch	D1	L1	L2	L3	L10	L4	L5	T1	Weight (Steel) kg/1 piece	Order code
2"	49	100	140	100	90	69.3	69.3	M16	8.03	TB432CFX
2 1/2"	60	120	160	120	100	83.4	83.4	M20	12.90	TB440CFX
3"	73	150	200	150	125	102.5	102.5	M24	25.80	TB448CFX
4"	85	180	240	180	150	123.7	123.7	M30	40.70	TB464CFX

Please change **suffixes** according to material/surface required

Order code suffixes			
Material	Suffix surface and material	Example	Comments
Steel, zinc plated, Cr(VI)-free	CF	LB432CFX	
Steel, oil dipped	S	LB432SX	
Stainless steel	SS	LB432SSX	

Please change **suffixes** according to material/surface required

Order code suffixes			
Material	Suffix surface and material	Example	Comments
Steel, zinc plated, Cr(VI)-free	CF	TB432CFX	
Steel, oil dipped	S	TB432SX	
Stainless steel	SS	TB432SSX	



TBR – Flange T-block reducer

ISO 6164

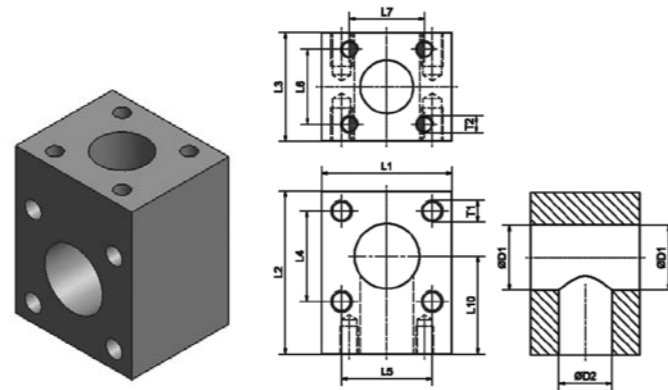

Size Inch	D1	D2	L1	L2	L3	L10	L4	L5	L6	L7	T1	T2	Weight (Steel) kg/1 piece	Order code
2 1/2 - 2"	60	49	120	150	100	90	83.4	83.4	69.3	69.3	M20	M16	10.2	TBR440-432-440CFX
3 - 2 1/2"	73	60	150	185	120	110	102.5	102.5	83.4	83.4	M24	M20	19.2	TBR448-440-448CFX
3 - 2"	73	49	150	175	100	100	102.5	102.5	69.3	69.3	M24	M16	15.2	TBR448-432-448CFX
4 - 3"	85	73	150	225	150	135	123.7	123.7	102.5	102.5	M30	M24	35.2	TBR464-448-464CFX
4 - 2 1/2"	85	60	180	215	120	125	123.7	123.7	83.4	83.4	M30	M20	26.9	TBR464-440-464CFX
4 - 2"	85	49	180	200	100	110	123.7	123.7	69.3	69.3	M30	M16	21.0	TBR464-432-464CFX

	A	B	C
TBR448-432-448	3"	2"	3"
TBR448-448-432	3"	3"	2"
TBR432-448-448	2"	3"	3"

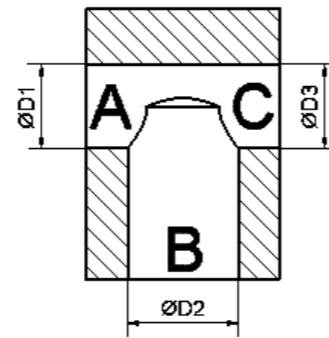

Please change suffixes according to material/surface required

Order code suffixes			
Material	Suffix surface and material	Example	Comments
Steel, zinc plated, Cr(VI)-free	CF	TBR448-432-448CFX	only flange block
Steel, oil dipped	S	TBR448-432-448SX	only flange block
Stainless steel	SS	TBR448-432-448SSX	only flange block



Bolts and nuts

ISO 6164

Size	Tube	Bolt ISO 4762 10.9				Nut ISO 4032 Tube/Tube	
		Description	Order code	Description	Order code	Description	Order code
3/4"	25x3.0	M8x50	ZYLS8X50109X	M8x100	ZYLS8X100109X	M8-10	ISO4032-M-8-10
3/4"	25x4.0	M8x50	ZYLS8X50109X	M8x100	ZYLS8X100109X	M8-10	ISO4032-M-8-10
1"	30x4.0	M10x55	ZYLS10X55109X	M10x110	ZYLS10X110109X	M10-10	ISO4032-M-10-10
1"	30x5.0	M10x55	ZYLS10X55109X	M10x110	ZYLS10X110109X	M10-10	ISO4032-M-10-10
1"	38x4.0	M10x55	ZYLS10X55109X	M10x110	ZYLS10X110109X	M10-10	ISO4032-M-10-10
1"	38x6.0	M10x55	ZYLS10X55109X	M10x110	ZYLS10X110109X	M10-10	ISO4032-M-10-10
1 1/4"	38x4.0	M12x70	ZYLS12X70109X	M12x120	ZYLS12X120109X	M12-10	ISO4032-M-12-10
1 1/4"	38x5.0	M12x70	ZYLS12X70109X	M12x120	ZYLS12X120109X	M12-10	ISO4032-M-12-10
1 1/4"	38x6.0	M12x70	ZYLS12X70109X	M12x120	ZYLS12X120109X	M12-10	ISO4032-M-12-10
1 1/4"	42x5.0	M12x70	ZYLS12X70109X	M12x120	ZYLS12X120109X	M12-10	ISO4032-M-12-10
1 1/2"	50x3.0	M16x90	ZYLS16X90109X	M16x170	ZYLS16X170109X	M16-10	ISO4032-M-16-10
1 1/2"	50x5.0	M16x90	ZYLS16X90109X	M16x170	ZYLS16X170109X	M16-10	ISO4032-M-16-10
1 1/2"	50x6.0	M16x90	ZYLS16X90109X	M16x170	ZYLS16X170109X	M16-10	ISO4032-M-16-10
1 1/2"	50x8.0	M16x90	ZYLS16X90109X	M16x170	ZYLS16X170109X	M16-10	ISO4032-M-16-10
2"	50x5.0	M16x90	ZYLS16X90109X	M16x170	ZYLS16X170109X	M16-10	ISO4032-M-16-10
2"	50x6.0	M16x90	ZYLS16X90109X	M16x170	ZYLS16X170109X	M16-10	ISO4032-M-16-10
2"	50x8.0	M16x90	ZYLS16X90109X	M16x170	ZYLS16X170109X	M16-10	ISO4032-M-16-10
2 1/2"	60x8.0	M20x100	ZYLS20X100109X	M20x190	ZYLS20X190109X	M20-10	ISO4032-M-20-10
2 1/2"	65x8.0	M20x100	ZYLS20X100109X	M20x190	ZYLS20X190109X	M20-10	ISO4032-M-20-10
2 1/2"	66x8.5	M20x100	ZYLS20X100109X	M20x190	ZYLS20X190109X	M20-10	ISO4032-M-20-10
2 1/2"	75x12.5	M20x100	ZYLS20X100109X	M20x190	ZYLS20X190109X	M20-10	ISO4032-M-20-10
3"	80x3.0	M24x110	ZYLS24X110109X	M24x200	ZYLS24X200109X	M24-10	ISO4032-M-24-10
3"	80x8.0	M24x110	ZYLS24X110109X	M24x200	ZYLS24X200109X	M24-10	ISO4032-M-24-10
3"	80x10.0	M24x110	ZYLS24X110109X	M24x200	ZYLS24X200109X	M24-10	ISO4032-M-24-10
3"	88x14.0	M24x110	ZYLS24X110109X	M24x200	ZYLS24X200109X	M24-10	ISO4032-M-24-10

Check torque details (see page 18)



Tube clamps

Programme overview

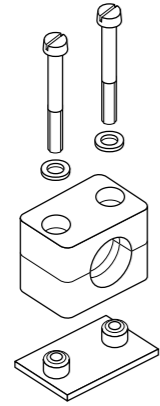
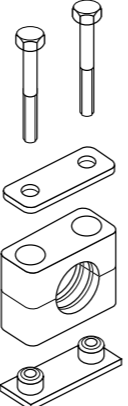
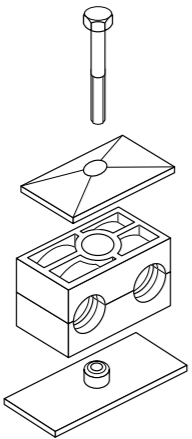
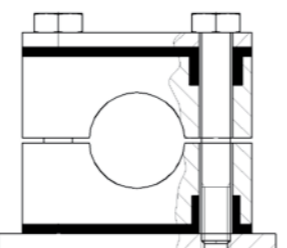
<p>Tube clamps series A</p>	 <p>Page 64 – 73</p>	<p>Tube clamps series C</p>	 <p>Page 79 – 89</p>
<p>Tube clamps series B</p>	 <p>Page 74 – 78</p>	<p>Tube clamps series C with absorbing noise insert</p>	 <p>Page 90 – 91</p>

Tube clamps

DIN 3015

Programme:

Tube clamps series A (according to DIN 3015 Part 1)

Available in seven standard sizes for normal mechanical requirements.

- Outer tube diameter for the metric series 6 to 57 mm
- Outer tube diameter for the inch-size series R 1/8" to R 1 1/2"
- Outer tube diameter for the imperial size series 1/4" to 2 1/2"

The clamp body is available in a round/closed version. Welding plates, rail-supports, cover plates and construction types.

Tube clamps series B (according to DIN 3015 Part 3)

Available as a twin tube clamp in five standard sizes for normal mechanical requirements. Outer tube diameter 6 to 42 mm. The clamp body is available in a square/open design. Welding plates, rail-supports, cover plates and construction types. Clamp halves with different diameters are only possible when used together.

Tube clamps series C (according to DIN 3015 Part 2)

Specially designed for high mechanical requirements, and available in eight standard sizes.

- Outer tube diameter 6 to 220 mm.

The clamp body is available in a square/closed design. Welding plates, rail-supports, cover plates and construction types.

Design:

According to DIN 3015: Both upper and lower clamp-halves are identical. Webs inside the bore of the clamps provide an impact and vibration deadening effect, and absorb the forces towards the direction of the tube axis. When using hoses and cables, we recommend the use of clamp halves with a smooth bore.

Clamp material:

Polypropylene	-30°C up to + 90° C	colour dark green
Polyamide	-40°C up to + 120° C	colour black
Rubber	-50°C up to + 120° C	colour black
Aluminium	up to + 300° C	

All metal parts available also in stainless steel.

Other materials upon request.

Stainless steel qualities

Stainless steel 1.4401/1.4571 (AISI 316/316 TI), resistant against rust and acid.

Accessories material:

Steel. Screws as well as cover plates of series A and B are galvanized.

Rail-supports are also available with zinc plated surface.

Resistance to stress:

The remarkable features of Tube Clamps are their considerable re-set capability, high tensile strength, as well as their very high output strength and excellent resistance to cold. The choice of design and clamp material depends on the specific demands of the mechanical and thermal requirements.

Order code:

The order code for clamp halves as well as the reference No. for complete tube clamps incorporates the serial indication, material description and interior surface.

Example of description:

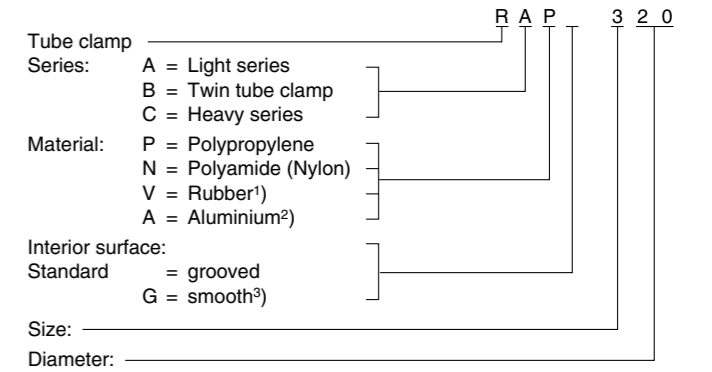

¹) Rubber only available for series A and B, inside smooth and series C grooved design
 ²) Aluminium only available for series A size 1 to 6 and series C size 1 to 8
 ³) Smooth interior surface in series C only to size 4
 Aluminium clamps only available in a grooved design
 Inside smooth series A only size 1 to 6

Registration:

German Lloyd, Lloyd s Register of Shipping and others.

Tube clamps material properties

DIN 3015

Mechanical properties		Polypropylene (PP)	Polyamide 6 (PA 6)	Aluminium	Rubber
Density		0.906 g/cm ³	1.12–1.15g/cm ³	2.65 g/cm ³	0.98 g/cm ³
Flexural deflection	DIN 53452	36 N/mm ²	130...200 N/mm ²	70 N/mm ²	–
Impact resistance	DIN 53453	no break	no break	–	
Compressive strength	DIN 53454	90 N/mm ²	120 N/mm ²	HB 500...600 N/mm ²	A and B: 64° shore C: 73° shore
Modulus of elasticity	DIN 53452	1500 N/mm ²	3000 N/mm ²	70.000 N/mm ²	
Tensile strength without breakage	DIN 53454	25–35 N/mm ²	80–90 N/mm ²	180 N/mm ²	A and B: 6.1 N/mm ² C: 8.5 N/mm ²
Thermal properties					
Temp. resistance		–30 ... + 90° C	–40 ... + 120°C	300° C	–50 ... +120°C
Chemical properties					
Weak acids		limited resistant	limited resistant		resistant
Weak alkalis		limited resistant	limited resistant		resistant
Alcohol		resistant	resistant		resistant
Petrol		limited resistant	resistant		limited resistant
Mineral oils		resistant	resistant		resistant
Other oils		resistant	resistant		resistant

The outlined particulars are approximate values and are only shown for reference, which are not binding, and with regard to possible protection of third parties. They do not exempt you from your own examination of suitability of the products delivered by us. Therefore, these values can only be used in a limited way for guidance only.

The application of the products is carried out outside of our control and, therefore, is exclusively subject to your own area of responsibility. Any claim however would be limited for all damages to the value of the goods supplied by us and in use by you.

It goes without saying, that we guarantee the perfect quality of our products according to our general sales and delivery conditions.

Tube clamps assembly instruction

DIN 3015

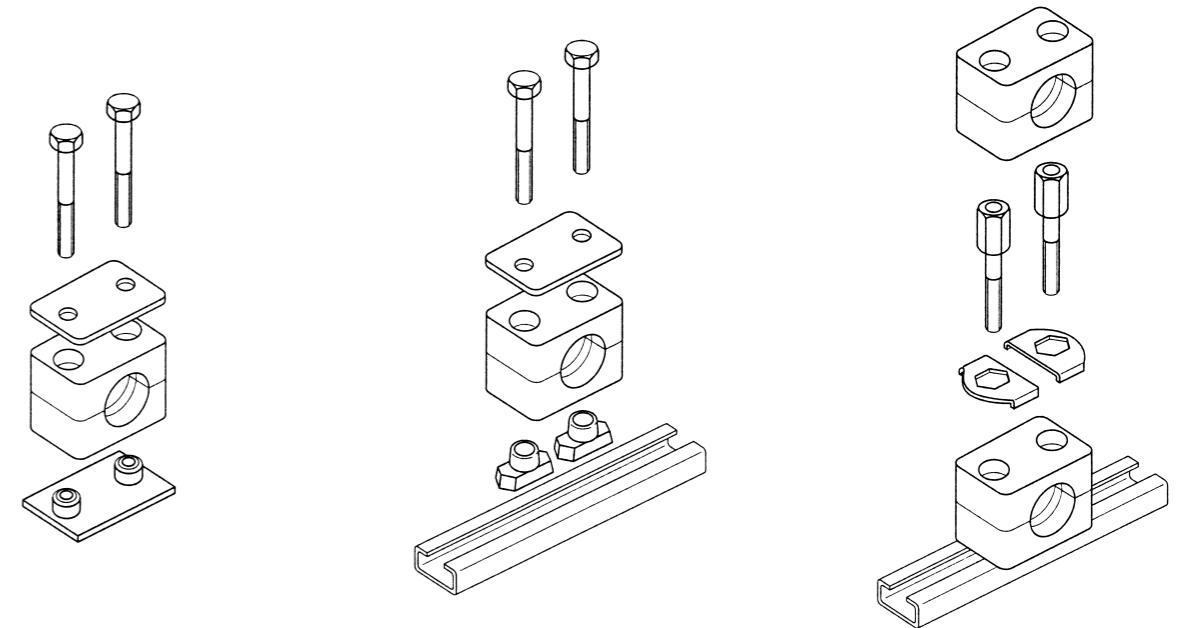

Assembly:

Assembly on to metal welding plates

Place welding plates on a base appropriate for the load. Make sure that the clamps are properly aligned. Clamp lower clamp halve onto welding plate, insert tube, place upper clamp halve onto lower halve and fasten with the screws. Attention must be paid to the bias (after completed assembly, clamp halves may not be in contact)! Do not weld with fitted plastic clamp! Extended welding plates may be screw-fastened to the base.

Assembly on support rails

Support rails are available in four different heights and come in pieces of 1 m or 2 m length, as required. Weld on support rail or screw-fasten with fastening angle bracket. Insert support rail nuts in rail and turn until stoppage. For heavy duty construction series, nuts are simply pushed in. Clamp lower clamp half on support rail nuts, insert tube, place upper clamp half onto lower half and fasten with the screws. Before fastening the screws the clamp may still be positioned. Attention must be paid to the bias (after completed assembly, the clamp halves may not be in contact)!

Construction assembly

Clamps allow the assembly of multiple clamps of the same construction size and of different tube diameters one above the other. The construction assembly is carried out with special fixing screws that are secured against twisting by applying a locking plate. Clamp lower clamp halve on welding plate or support rail respectively, insert tube, place upper clamp half on lower half and fasten with fixing screws. The fixing screw juts out from the upper clamp halve. The application of a locking plate securely fastens the fixing screw and prevents twisting. Clamp on second clamp halve on to the fixing screws etc.

Tube clamps series A (Light construction series) – Components

DIN 3015, part 1

Order code for clamp halves:

- Polypropylene – **RAP**
- Inside smooth – **RAPG**
- Polyamide 6 – **RAN**
- Inside smooth – **RANG**
- Rubber – **RAVG**
- Aluminium – **RAA¹⁾**

(Please exchange as required standard abbreviation RAP in column for "clamp halves")

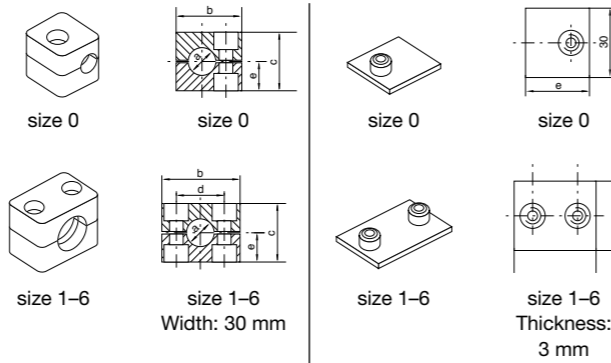

clamp size	Tube O.D. mm a	Tube NB	Tube O.D.	1 part 2 clamp halves		welding plate, short	
				RAP... Order code	dimensions: b c d e	APK A... Order code	dimensions: d e
0	6	G ¹ / ₈	1/4	RAP006X RAP006.4X RAP008X RAP009.5X RAP010X RAP012X	28 27 – 13.5	APKA0X	– 30
	6.4						
	8						
	9.5						
	10						
1	12	G ¹ / ₈	1/4	RAP106X RAP106.4X RAP108X RAP109.5X RAP110X RAP112X	34 27 20 13.5	APKA1X	20 36
	6						
	6.4						
	8						
	9.5						
2	10	G ¹ / ₄	1/2	RAP212.7X RAP213.5X RAP214X RAP215X RAP216X RAP217.2X RAP218X	40 33 26 16.5	APKA2X	26 42
	12						
	12.7						
	13.5						
	14						
3	15	G ³ / ₈	5/8	RAP319X RAP320X RAP321.3X RAP322X RAP323X RAP325X	48 35 33 17.5	APKA3X	33 50
	16						
	17.2						
	18						
	19						
4	20	G ³ / ₄		RAP426.9X RAP428X RAP430X	57 42 40 21	APKA4X	40 59
	21.3						
	22						
	23						
	25						
5	26.9	G1	1 1/4	RAP532X RAP533.7X RAP535X RAP538X RAP540X RAP542X	70 58 52 29	APKA5X	52 72
	28						
	30						
	32						
	33.7						
6	35	G1 1/4	1 1/2	RAP644.5X RAP645X RAP648X RAP650X RAP650.8X RAP652X RAP655X RAP657X	86 66 66 33	APKA6X	66 88
	38						
	40						
	42						
	44.5						
	45	G1 1/2	1 3/4				
	48						
	50						
	50.8						
	52						
	55	2					
	57						
			2 1/4				

When assembling solid rubber clamps, covering plates, hexagon screws and locking washers must be used. All metal parts available in stainless steel.
¹⁾ Aluminium only sizes 1 to 6.

Tube clamps series A (Light construction series) – Components

DIN 3015, part 1

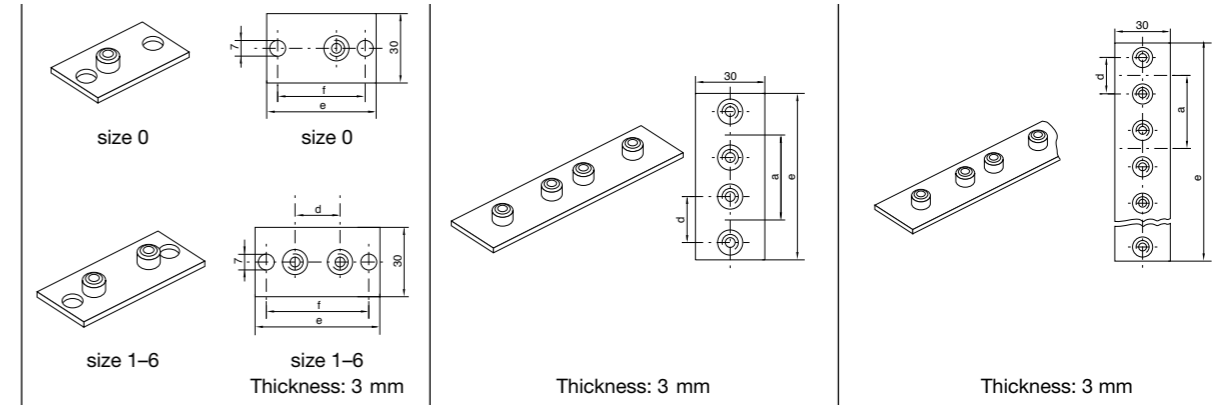

clamp size	weld/screw plate, long			twin welding plate			multiple weld plate		
	APL A... Order code	dimensions: d e f		APD A... Order code	dimensions: d a e		APR A... Order code	dimensions: d a e	
0	APLA0X	– 58 44		APDA0X	– 30 61		APRA0X (10 clamps)	– 30 298	
1	APLA1X	20 64 50		APDA1X	20 35 69		APRA1X (10 clamps)	20 35 349	
2	APLA2X	26 70 56		APDA2X	26 43 86		APRA2X (10 clamps)	26 43 427	
3	APLA3X	33 78 64		APDA3X	33 52 104		APRA3X (10 clamps)	33 52 516	
4	APLA4X	40 87 73		APDA4X	40 60 117		APRA4X (5 clamps)	40 60 297	
5	APLA5X	52 100 86		APDA5X	52 75 145		APRA5X (5 clamps)	52 75 370	
6	APLA6X	66 116 100		APDA6X	66 90 176		APRA6X (5 clamps)	66 90 446	

Metal parts also available in stainless steel.



Tube clamps series A (Light construction series) – Components

DIN 3015, part 1

clamp size	weld plate, angled		mounting rail		rail nut				
	APW A... Order code	dimensions: d e	TS...A/B Order code	dimensions: h	TM...A/B1 Order code	dimensions: a b c m			
0	APWA0X	14 30	TS11A/B1X TS11A/B2X TS14A/B1X TS14A/B2X TS30A/B1X TS30A/B2X	TS11: 11 TS14: 14 TS30: 30	TMA/TMB1VERZX	25.4	10.4	12	M6
1	APWA1X	20 36							
2	APWA2X	26 42							
3	APWA3X	33 50							
4	APWA4X	40 59							
5	APWA5X	52 72							
6	APWA6X	66 88							

Metal parts also available in stainless steel.

Tube clamps series A (Light construction series) – Components

DIN 3015, part 1

clamp size	cover plate		slot head		hexagon head		socket head	
	DP A... Order code	dimensions: b d	SL A... Order code	dimensions: d x L	SSL A... Order code	dimensions: d x L	IS A... Order code	dimensions: d x L
0	DPA0X	- -	SLA0X	M 6 x 20	SSL10X	M 6 x 30	ISA0X	M 6 x 20
1	DPA1X	34 20	SLA1X	M 6 x 20	SSLA0X	M 6 x 30	ISA1X	M 6 x 20
2	DPA2X	40 26	SLA2X	M 6 x 25	SSLA2/SSB1X	M 6 x 35	ISA2X	M 6 x 25
3	DPA3X	48 33	SLA3X	M 6 x 30	SSLA3X	M 6 x 40	ISA3X	M 6 x 30
4	DPA4X	57 40	SLA4X	M 6 x 35	SSLA4X	M 6 x 45	ISA4X	M 6 x 35
5	DPA5X	70 52	SLA5X	M 6 x 50	SSLA5X	M 6 x 60	ISA5X	M 6 x 50
6	DPA6X	86 66	SLA6X	M 6 x 60	SSLA6X	M 6 x 70	ISA6X	M 6 x 60

All metal parts available in stainless steel.

Tube clamps series A (Light construction series) – Components

DIN 3015, part 1

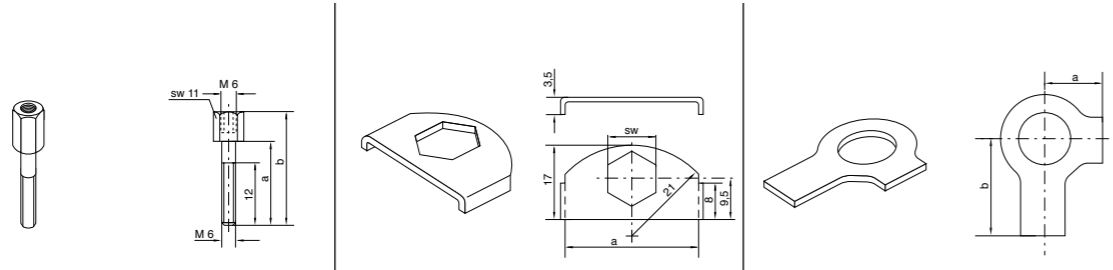

clamp size	stacking ¹⁾		locking plate ¹⁾		locking washer ²⁾	
	AS A... Order code	dimensions: a b	SB A Order code	dimensions: a SW	US A Order code	dimensions: a b
0	ASA0X (AS B1X)	20 34	SBAX	30 11	USA/USB1X	9 18
1	ASA0X (ASB1X)	20 34				
2	ASA2X	25 39				
3	ASA3X	30 44				
4	ASA4X	35 49				
5	ASA5X	50 64				
6	ASA6X	60 74				

¹⁾ The use of stacking bolts necessitates the use of locking plates in the construction assembly.

²⁾ When assembling solid rubber clamps, cover plates, hexagon screws and locking washers must be used.

Metal parts also available in stainless steel.

Tube clamps series A (Light construction series) – Complete range

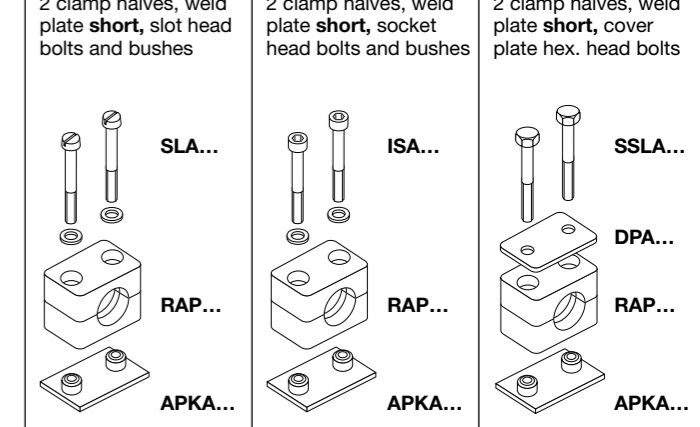

Polypropylene – **RAP**
 Inside smooth – **RAPG**
 Polyamide 6 – **RAN**
 Inside smooth – **RANG**
 Rubber – **RAVG***
 Aluminium – **RAA**

(As required please exchange standard abbreviation RAP in column for "Order code")

clamp size	Tube O.D. mm	Tube NB	Tube O.D.	Order code	Order code	Order code
0 ¹⁾	6	G ¹ / ₈	1/4	RAP1-006	RAP2-006	RAP3-006
	6.4			RAP1-006.4	RAP2-006.4	RAP3-006.4
	8			RAP1-008	RAP2-008	RAP3-008
	9.5			RAP1-009.5	RAP2-009.5	RAP3-009.5
	10			RAP1-010	RAP2-010	RAP3-010
1	12	G ¹ / ₈	3/8	RAP1-012	RAP2-012	RAP3-012
	6			RAP1-106	RAP2-106	RAP3-106
	6.4			RAP1-106.4	RAP2-106.4	RAP3-106.4
	8			RAP1-108	RAP2-108	RAP3-108
	9.5			RAP1-109.5	RAP2-109.5	RAP3-109.5
2	10	G ¹ / ₈	5/8	RAP1-110	RAP2-110	RAP3-110
	12			RAP1-112	RAP2-112	RAP3-112
	12.7			RAP1-212.7	RAP2-212.7	RAP3-212.7
	13.5			RAP1-213.5	RAP2-213.5	RAP3-213.5
	14			RAP1-214	RAP2-214	RAP3-214
3	15	G ³ / ₈	1	RAP1-215	RAP2-215	RAP3-215
	16			RAP1-216	RAP2-216	RAP3-216
	17.2			RAP1-217.2	RAP2-217.2	RAP3-217.2
	18			RAP1-218	RAP2-218	RAP3-218
	19			RAP1-319	RAP2-319	RAP3-319
4	20	G ¹ / ₂	3/4	RAP1-320	RAP2-320	RAP3-320
	21.3			RAP1-321.3	RAP2-321.3	RAP3-321.3
	22			RAP1-322	RAP2-322	RAP3-322
	23			RAP1-323	RAP2-323	RAP3-323
	25			RAP1-325	RAP2-325	RAP3-325
5	26.9	G ³ / ₄	1	RAP1-426.9	RAP2-426.9	RAP3-426.9
	28			RAP1-428	RAP2-428	RAP3-428
	30			RAP1-430	RAP2-430	RAP3-430
	32			RAP1-532	RAP2-532	RAP3-532
	33.7			RAP1-533.7	RAP2-533.7	RAP3-533.7
6	35	G 1	1 1/4	RAP1-535	RAP2-535	RAP3-535
	38			RAP1-538	RAP2-538	RAP3-538
	40			RAP1-540	RAP2-540	RAP3-540
	42			RAP1-542	RAP2-542	RAP3-542
	44.5			RAP1-644.5	RAP2-644.5	RAP3-644.5
6	45	G ¹ / ₂	1 3/4	RAP1-645	RAP2-645	RAP3-645
	48			RAP1-648	RAP2-648	RAP3-648
	50			RAP1-650	RAP2-650	RAP3-650
	50.8			RAP1-650.8	RAP2-650.8	RAP3-650.8
	52			RAP1-652	RAP2-652	RAP3-652
	55			RAP1-655	RAP2-655	RAP3-655
	57			RAP1-657	RAP2-657	RAP3-657

Delivery in unassembled individual components.

¹⁾ Contrary to the illustration size 0 clamps are secured by only one screw.

* Only with cover plate, hexagon screws and locking washers.



Tube clamps series A (Light construction series) – Complete range

Polypropylene – **RAP**
 Inside smooth – **RAPG**
 Polyamide 6 – **RAN**
 Inside smooth – **RANG**
 Rubber – **RAVG***
 Aluminium – **RAA**

(As required please exchange standard abbreviation RAP in column for "Order code")

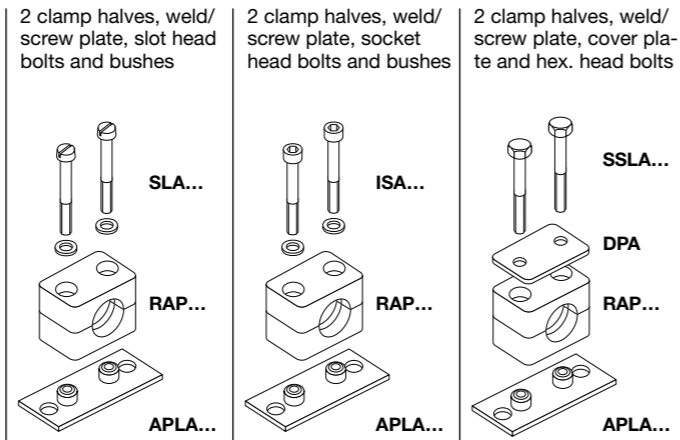

clamp size	Tube O.D. mm	Tube NB	Tube O.D.	Order code	Order code	Order code			
0 ¹⁾	6	G ¹ / ₈	1/4	RAP4-006	RAP5-006	RAP6-006			
	6.4			RAP4-006.4	RAP5-006.4	RAP6-006.4			
	8			RAP4-008	RAP5-008	RAP6-008			
	9.5			RAP4-009.5	RAP5-009.5	RAP6-009.5			
	10			RAP4-010	RAP5-010	RAP6-010			
1	12	G ¹ / ₈	3/8	RAP4-012	RAP5-012	RAP6-012			
	6			RAP4-106	RAP5-106	RAP6-106			
	6.4			RAP4-106.4	RAP5-106.4	RAP6-106.4			
	8			RAP4-108	RAP5-108	RAP6-108			
	9.5			RAP4-109.5	RAP5-109.5	RAP6-109.5			
2	10	G ³ / ₈	5/8	RAP4-110	RAP5-110	RAP6-110			
	12			RAP4-112	RAP5-112	RAP6-112			
	12.7			RAP4-212.7	RAP5-212.7	RAP6-212.7			
	13.5			RAP4-213.5	RAP5-213.5	RAP6-213.5			
	14			RAP4-214	RAP5-214	RAP6-214			
	15			RAP4-215	RAP5-215	RAP6-215			
	16			RAP4-216	RAP5-216	RAP6-216			
3	17.2	G ³ / ₈	1	RAP4-217.2	RAP5-217.2	RAP6-217.2			
	18			RAP4-218	RAP5-218	RAP6-218			
	19			RAP4-319	RAP5-319	RAP6-319			
	20			RAP4-320	RAP5-320	RAP6-320			
	21.3			RAP4-321.3	RAP5-321.3	RAP6-321.3			
4	22	G ¹ / ₂	1	RAP4-322	RAP5-322	RAP6-322			
	23			RAP4-323	RAP5-323	RAP6-323			
	25			RAP4-325	RAP5-325	RAP6-325			
	26.9			RAP4-426.9	RAP5-426.9	RAP6-426.9			
	28			RAP4-428	RAP5-428	RAP6-428			
5	30	G ³ / ₄	1 1/4	RAP4-430	RAP5-430	RAP6-430			
	32			RAP4-532	RAP5-532	RAP6-532			
	33.7			RAP4-533.7	RAP5-533.7	RAP6-533.7			
	35			RAP4-535	RAP5-535	RAP6-535			
	38			RAP4-538	RAP5-538	RAP6-538			
	40			RAP4-540	RAP5-540	RAP6-540			
	42			RAP4-542	RAP5-542	RAP6-542			
6	44.5	G1 1/2	2	RAP4-644.5	RAP5-644.5	RAP6-644.5			
	45			RAP4-645	RAP5-645	RAP6-645			
	48			RAP4-648	RAP5-648	RAP6-648			
	50			RAP4-650	RAP5-650	RAP6-650			
	50.8			RAP4-650.8	RAP5-650.8	RAP6-650.8			
	52			RAP4-652	RAP5-652	RAP6-652			
	55			RAP4-655	RAP5-655	RAP6-655			
	57			RAP4-657	RAP5-657	RAP6-657			
						1 3/4			
						2 1/4			

Delivery in unassembled individual components.

¹⁾ Contrary to the illustration size 0 clamps are secured by only one screw.
 * Only with cover plate, hexagon screws and locking washers.



Tube clamps series A (Light construction series) – Complete range

Polypropylene – **RAP**
 Inside smooth – **RAPG**
 Polyamide 6 – **RAN**
 Inside smooth – **RANG**
 Rubber – **RAVG***
 Aluminium – **RAA**

(As required please exchange standard abbreviation RAP in column for "Order code")

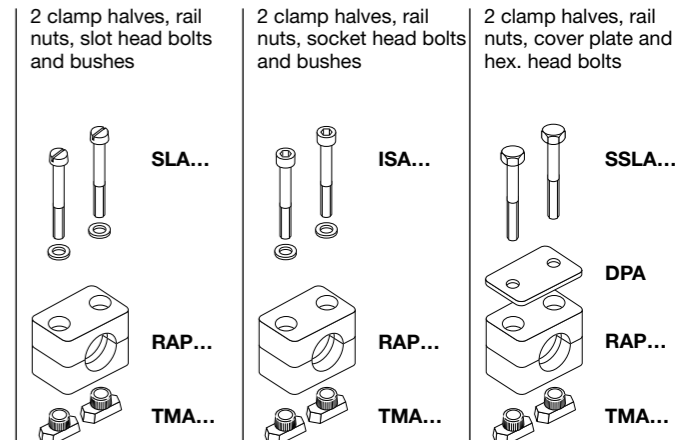

clamp size	Tube O.D. mm	Tube NB	Tube O.D.	Order code	Order code	Order code			
0 ¹⁾	6	G ¹ / ₈	1/4	RAP9-006	RAP10-006	RAP12-006			
	6.4			RAP9-006.4	RAP10-006.4	RAP12-006.4			
	8			RAP9-008	RAP10-008	RAP12-008			
	9.5			RAP9-009.5	RAP10-009.5	RAP12-009.5			
	10			RAP9-010	RAP10-010	RAP12-010			
1	12	G ¹ / ₈	3/8	RAP9-012	RAP10-012	RAP12-012			
	6			RAP9-106	RAP10-106	RAP12-106			
	6.4			RAP9-106.4	RAP10-106.4	RAP12-106.4			
	8			RAP9-108	RAP10-108	RAP12-108			
	9.5			RAP9-109.5	RAP10-109.5	RAP12-109.5			
2	10	G ¹ / ₈	5/8	RAP9-110	RAP10-110	RAP12-110			
	12			RAP9-112	RAP10-112	RAP12-112			
	12.7			RAP9-212.7	RAP10-212.7	RAP12-212.7			
	13.5			RAP9-213.5	RAP10-213.5	RAP12-213.5			
	14			RAP9-214	RAP10-214	RAP12-214			
	15			RAP9-215	RAP10-215	RAP12-215			
	16			RAP9-216	RAP10-216	RAP12-216			
3	17.2	G ³ / ₈	1	RAP9-217.2	RAP10-217.2	RAP12-217.2			
	18			RAP9-218	RAP10-218	RAP12-218			
	19			RAP9-319	RAP10-319	RAP12-319			
	20			RAP9-320	RAP10-320	RAP12-320			
	21.3			RAP9-321.3	RAP10-321.3	RAP12-321.3			
4	22	G ¹ / ₂	1	RAP9-322	RAP10-322	RAP12-322			
	23			RAP9-323	RAP10-323	RAP12-323			
	25			RAP9-325	RAP10-325	RAP12-325			
	26.9			RAP9-426.9	RAP10-426.9	RAP12-426.9			
	28			RAP9-428	RAP10-428	RAP12-428			
5	30	G ³ / ₄	1 1/4	RAP9-430	RAP10-430	RAP12-430			
	32			RAP9-532	RAP10-532	RAP12-532			
	33.7			RAP9-533.7	RAP10-533.7	RAP12-533.7			
	35			RAP9-535	RAP10-535	RAP12-535			
	38			RAP9-538	RAP10-538	RAP12-538			
	40			RAP9-540	RAP10-540	RAP12-540			
	42			RAP9-542	RAP10-542	RAP12-542			
6	44.5	G1 1/2	2	RAP9-644.5	RAP10-644.5	RAP12-644.5			
	45			RAP9-645	RAP10-645	RAP12-645			
	48			RAP9-648	RAP10-648	RAP12-648			
	50			RAP9-650	RAP10-650	RAP12-650			
	50.8			RAP9-650.8	RAP10-650.8	RAP12-650.8			
	52			RAP9-652	RAP10-652	RAP12-652			
	55			RAP9-655	RAP10-655	RAP12-655			
	57			RAP9-657	RAP10-657	RAP12-657			
						1 3/4			
						2 1/4			

Delivery in unassembled individual components.

¹⁾ Contrary to the illustration size 0 clamps are secured by only one screw.
 * Only with cover plate, hexagon screws and locking washers.

Tube clamps series A – Complete range

Polypropylene – **RAP**
 Inside smooth – **RAPG**
 Polyamide 6 – **RAN**
 Inside smooth – **RANG**
 Rubber – **RAVG***
 Aluminium – **RAA**

(As required please exchange standard abbreviation RAP in column for "Order code")

2 clamp halves, slot heads and bushes

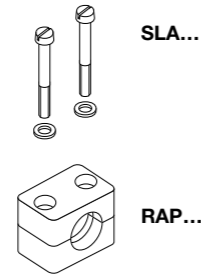

2 clamp halves, socket head bolts and bushes

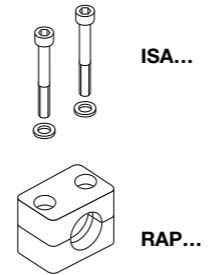

clamp size	Tube O.D. mm	Tube NB	Tube O.D.	Order code	Order code
0 ¹⁾	6	G ¹ / ₈	1/4	RAP13-006	RAP14-006
	6.4			RAP13-006.4	RAP14-006.4
	8			RAP13-008	RAP14-008
	9.5			RAP13-009.5	RAP14-009.5
	10			RAP13-010	RAP14-010
1	12	G ¹ / ₈	3/8	RAP13-012	RAP14-012
	6			RAP13-106	RAP14-106
	6.4			RAP13-106.4	RAP14-106.4
	8			RAP13-108	RAP14-108
	9.5			RAP13-109.5	RAP14-109.5
2	10	G ³ / ₈	5/8	RAP13-110	RAP14-110
	12			RAP13-112	RAP14-112
	12.7			RAP13-212.7	RAP14-212.7
	13.5			RAP13-213.5	RAP14-213.5
	14			RAP13-214	RAP14-214
3	15	G ¹ / ₂	1	RAP13-215	RAP14-215
	16			RAP13-216	RAP14-216
	17.2			RAP13-217.2	RAP14-217.2
	18			RAP13-218	RAP14-218
	19			RAP13-319	RAP14-319
4	20	G ³ / ₄	1	RAP13-320	RAP14-320
	21.3			RAP13-321.3	RAP14-321.3
	22			RAP13-322	RAP14-322
	23			RAP13-323	RAP14-323
	25			RAP13-325	RAP14-325
5	26.9	G1	1 1/4	RAP13-426.9	RAP14-426.9
	28			RAP13-428	RAP14-428
	30			RAP13-430	RAP14-430
	32			RAP13-532	RAP14-532
	33.7			RAP13-533.7	RAP14-533.7
6	35	G1 1/4	1 1/2	RAP13-535	RAP14-535
	38			RAP13-538	RAP14-538
	40			RAP13-540	RAP14-540
	42			RAP13-542	RAP14-542
	44.5			RAP13-644.5	RAP14-644.5
6	45	G1 1/2	2	RAP13-645	RAP14-645
	48			RAP13-648	RAP14-648
	50			RAP13-650	RAP14-650
	50.8			RAP13-650.8	RAP14-650.8
	52			RAP13-652	RAP14-652
6	55	G1 1/2	2 1/4	RAP13-655	RAP14-655
	57			RAP13-657	RAP14-657

Delivery in unassembled individual components.

¹⁾ Contrary to the illustration size 0 clamps are secured by only one screw.
 * Only with cover plate, hexagon screws and locking washers.



Tube clamps series A – Complete range

Polypropylene – **RAP**
 Inside smooth – **RAPG**
 Polyamide 6 – **RAN**
 Inside smooth – **RANG**
 Rubber – **RAVG***
 Aluminium – **RAA**

(As required please exchange standard abbreviation RAP in column for "Order code")

2 clamp halves, cover plate and hex. head bolts

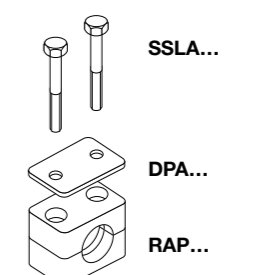

2 clamp halves, stacking bolts and locking plate

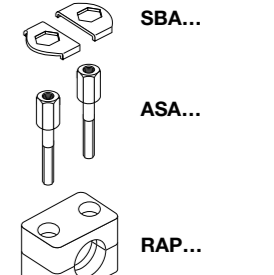

clamp size	Tube O.D. mm	Tube NB	Tube O.D.	Order code	Order code
0 ¹⁾	6	G ¹ / ₈	1/4	RAP16-006	RAP18-006
	6.4			RAP16-006.4	RAP18-006.4
	8			RAP16-008	RAP18-008
	9.5			RAP16-009.5	RAP18-009.5
	10			RAP16-010	RAP18-010
1	12	G ¹ / ₈	3/8	RAP16-012	RAP18-012
	6			RAP16-106	RAP18-106
	6.4			RAP16-106.4	RAP18-106.4
	8			RAP16-108	RAP18-108
	9.5			RAP16-109.5	RAP18-109.5
2	10	G ³ / ₈	5/8	RAP16-110	RAP18-110
	12			RAP16-112	RAP18-112
	12.7			RAP16-212.7	RAP18-212.7
	13.5			RAP16-213.5	RAP18-213.5
	14			RAP16-214	RAP18-214
3	15	G ¹ / ₂	1	RAP16-215	RAP18-215
	16			RAP16-216	RAP18-216
	17.2			RAP16-217.2	RAP18-217.2
	18			RAP16-218	RAP18-218
	19			RAP16-319	RAP18-319
4	20	G ³ / ₄	1	RAP16-320	RAP18-320
	21.3			RAP16-321.3	RAP18-321.3
	22			RAP16-322	RAP18-322
	23			RAP16-323	RAP18-323
	25			RAP16-325	RAP18-325
5	26.9	G1	1 1/4	RAP16-426.9	RAP18-426.9
	28			RAP16-428	RAP18-428
	30			RAP16-430	RAP18-430
	32			RAP16-532	RAP18-532
	33.7			RAP16-533.7	RAP18-533.7
6	35	G1 1/4	1 1/2	RAP16-535	RAP18-535
	38			RAP16-538	RAP18-538
	40			RAP16-540	RAP18-540
	42			RAP16-542	RAP18-542
	44.5			RAP16-644.5	RAP18-644.5
6	45	G1 1/2	2	RAP16-645	RAP18-645
	48			RAP16-648	RAP18-648
	50			RAP16-650	RAP18-650
	50.8			RAP16-650.8	RAP18-650.8
	52			RAP16-652	RAP18-652
6	55	G1 1/2	2 1/4	RAP16-655	RAP18-655
	57			RAP16-657	RAP18-657

Delivery in unassembled individual components.

¹⁾ Contrary to the illustration size 0 clamps are secured by only one screw.
 * Only with cover plate, hexagon screws and locking washers.

Tube clamps series B (Twin-tube clamps) – Components

DIN 3015, part 3

Order code for clamp halves:

- Polypropylene – **RBP**
- Inside smooth – **RBP**G
- Polyamide 6 – **RBN**
- Rubber – **RBV**G

(Please exchange standard abbreviation RBP in column for “clamp halves” as required.)

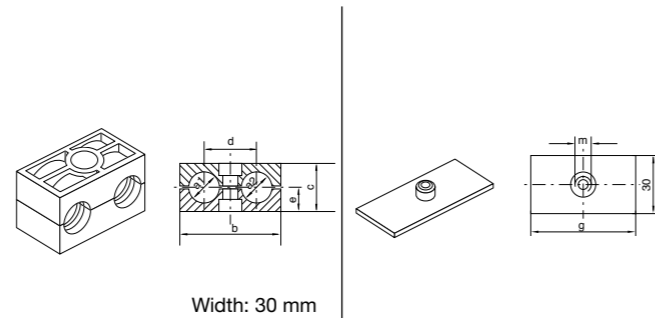

clamp size	Tube O.D. mm	Tube NB	Tube O.D.	1 part 2 clamp halves ¹⁾		weld plate	
				RBP... Order code	dimensions: b c d e	APB... Order code	dimensions: g m
1	6	G ¹ / ₈	1/4	RBP106X	36 27 20 13.5	APB1X	37 M 6
	6.4						
	8						
	9.5						
	10						
2	12	G ³ / ₈	1/2	RBP109.5X	53 26 29 13	APB2X	55 M 8
	12.7						
	13.5						
	14						
	15						
3	16	G ¹ / ₂	3/4	RBP110X	67 37 36 18.5	APB3X	70 M 8
	17.2						
	18						
	19						
	20						
4	21.3	G ³ / ₄	1	RBP112X	82 42 45 21	APB4X	85 M 8
	22						
	25						
5	26.9	G1	1 1/4	RBP212.7X	106 54 56 27	APB5X	110 M 8
	28						
	30						
	32						
	33.7						

Metal parts also available in stainless steel.

¹⁾ Twin-tube clamps with different outer tube diameters upon request.



Tube clamps series B (Twin-tube clamps) – Components

DIN 3015, part 3

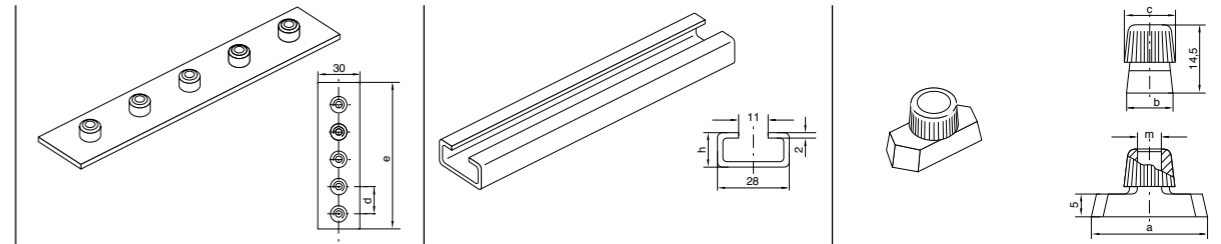

clamp size	multiple weld plate		mounting rail		rail nut	
	APRB... Order code	dimensions: d e	TS... A/B Order code	dimensions: h	TM... Order code	dimensions: a b c m
1	APRB1X (5 clamps)	40 196 Thickness: 3 mm	TS11A/B1X TS11A/B2X TS14A/B1X TS14A/B2X TS30A/B1X TS30A/B2X	TS11: 11 TS14: 14 TS30: 30	TMA/TMB1VERZX	25.4 10.4 12 M 6
2	APRB2X (5 clamps)	58 288 Thickness: 5 mm			TMB2X	25.4 10.4 12 M 8
3	APRB3X (5 clamps)	72 358 Thickness: 5 mm				
4	APRB4X (5 clamps)	90 446 Thickness: 5 mm				
5	APRB5X (5 clamps)	112 558 Thickness: 5 mm				

Tube clamps series B (Twin-tube clamps) – Components

DIN 3015, part 3

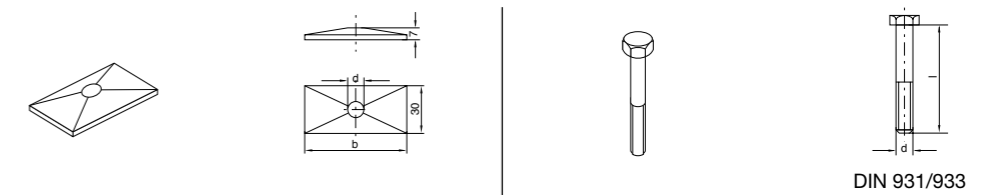

clamp size	cover plate		hexagonal head	
	DP B... Order code	dimensions: b d	SS B... Order code	dimensions: d x L
1	DPB1X	34 6.6	SSLA2/SSB1X	M 6 x 35
2	DPB2X	51 8.6	SSB2X	M 8 x 35
3	DPB3X	64 8.6	SSB3X	M 8 x 45
4	DPB4X	78 8.6	SSB4X	M 8 x 50
5	DPB5X	102 8.6	SSB5X	M 8 x 60

Metal parts also available in stainless steel.

Tube clamps series B (Twin-tube clamps) – Components

DIN 3015, part 3

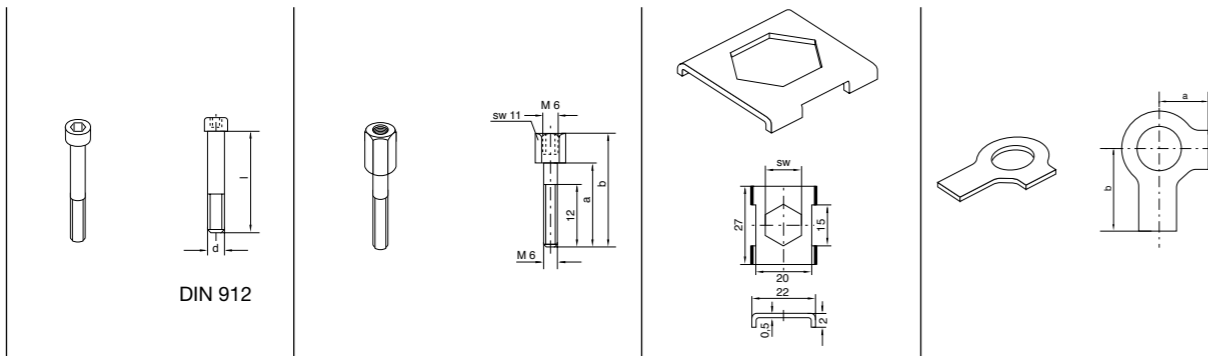

clamp size	socket head		stacking				locking plate ¹⁾		locking washer ²⁾		
	IS B... Order code	dimensions: d x L	AS B... Order code	dimensions:			SB B... Order code	dimensions: SW	US... Order code	dimensions: a b	
1	ISA4X (ISB1X)	M 6 x 35	ASA0X (ASB1X)	20	34	M 6	11	SBB1X	11	USA/USB1X	9 18
2	ISB2X	M 8 x 35	ASB2X	20	33	M 8	12	SBB2X	12	USB2X	11 20
3	ISB3X	M 8 x 45	ASB3X	29	44	M 8	12				
4	ISB4X	M 8 x 50	ASB4X	34	49	M 8	12				
5	ISB5X	M 8 x 60	ASB5X	47	62	M 8	12				

¹⁾ The use of stacking screws necessitates the use of locking plates in the construction assembly!

²⁾ When assembling solid rubber clamps, covering plates, hexagon screws and locking washers must be used. Metal parts also available in stainless steel.

Tube clamps series B – Complete range

Polypropylene – **RBP**
 Inside smooth – **RBPG**
 Polyamide 6 – **RBN**
 Rubber – **RBVG***

(As required please exchange standard abbreviation RBP in column for "Order code")

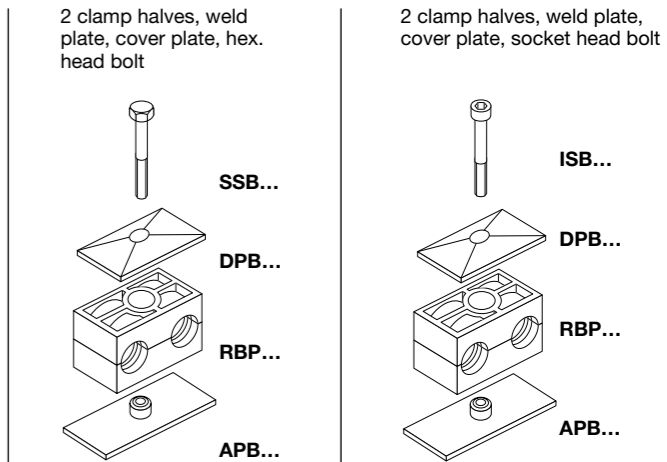

clamp size	Tube O.D. mm	Tube NB	Tube O.D.	Order code	Order code
1	6	G ¹ / ₈	1/4	RBP1-106	RBP3-106
	6.4			RBP1-106.4	RBP3-106.4
	8			RBP1-108	RBP3-108
	9.5			RBP1-109.5	RBP3-109.5
	10			RBP1-110	RBP3-110
	12			RBP1-112	RBP3-112
2	12.7	G ¹ / ₄	1/2	RBP1-212.7	RBP3-212.7
	13.5			RBP1-213.5	RBP3-213.5
	14			RBP1-214	RBP3-214
	15			RBP1-215	RBP3-215
	16			RBP1-216	RBP3-216
	17.2			RBP1-217.2	RBP3-217.2
3	18	G ³ / ₈	5/8	RBP1-218	RBP3-218
	19			RBP1-319	RBP3-319
	20			RBP1-320	RBP3-320
	21.3			RBP1-321.3	RBP3-321.3
	22			RBP1-322	RBP3-322
4	25	G ¹ / ₂	1	RBP1-325	RBP3-325
	26.9			RBP1-426.9	RBP3-426.9
	28			RBP1-428	RBP3-428
	30			RBP1-430	RBP3-430
5	32	G ³ / ₄	1 1/4	RBP1-532	RBP3-532
	33.7			RBP1-533.7	RBP3-533.7
	35			RBP1-535	RBP3-535
	38			RBP1-538	RBP3-538
	42			RBP1-542	RBP3-542

Delivery in unassembled individual components.

*Only with cover plate, hexagon screws and locking washers.

Tube clamps series B – Complete range

Polypropylene – **RBP**
 Inside smooth – **RBPG**
 Polyamide 6 – **RBN**
 Rubber – **RBVG***

(As required please exchange standard abbreviation RBP in column for "Order code")

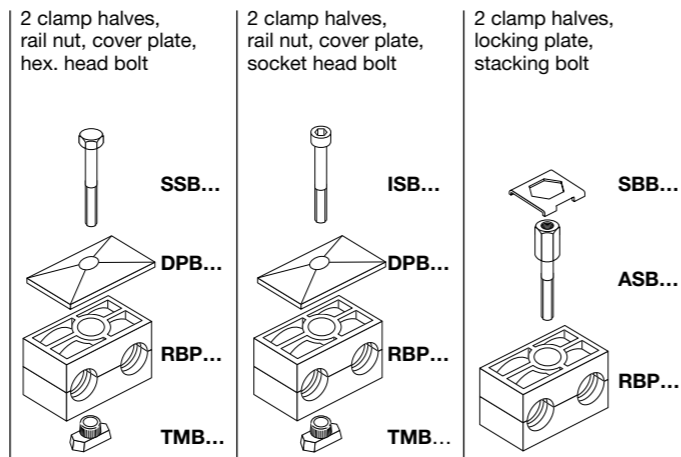

clamp size	Tube O.D. mm	Tube NB	Tube O.D.	Order code	Order code	Order code
1	6	G 1/8	1/4	RBP4-106	RBP5-106	RBP8-106
	6.4			RBP4-106.4	RBP5-106.4	RBP8-106.4
	8			RBP4-108	RBP5-108	RBP8-108
	8.5			RBP4-109.5	RBP5-109.5	RBP8-109.5
	10			RBP4-110	RBP5-110	RBP8-110
	12			RBP4-112	RBP5-112	RBP8-112
2	12.7	G 1/4	1/2	RBP4-212.7	RBP5-212.7	RBP8-212.7
	13.5			RBP4-213.5	RBP5-213.5	RBP8-213.5
	14			RBP4-214	RBP5-214	RBP8-214
	15			RBP4-215	RBP5-215	RBP8-215
	16			RBP4-216	RBP5-216	RBP8-216
	17.2			RBP4-217.2	RBP5-217.2	RBP8-217.2
3	18	G 3/8	5/8	RBP4-218	RBP5-218	RBP8-218
	19			RBP4-319	RBP5-319	RBP8-319
	20			RBP4-320	RBP5-320	RBP8-320
	21.3			RBP4-321.3	RBP5-321.3	RBP8-321.3
	22			RBP4-322	RBP5-322	RBP8-322
	25			RBP4-325	RBP5-325	RBP8-325
4	26.9	G 3/4	1	RBP4-426.9	RBP5-426.9	RBP8-426.9
	28			RBP4-428	RBP5-428	RBP8-428
	30			RBP4-430	RBP5-430	RBP8-430
5	32	G 1	1 1/4	RBP4-532	RBP5-532	RBP8-532
	33.7			RBP4-533.7	RBP5-533.7	RBP8-533.7
	35			RBP4-535	RBP5-535	RBP8-535
	38			RBP4-538	RBP5-538	RBP8-538
	42			RBP4-542	RBP5-542	RBP8-542
				RBP4-542	RBP5-542	RBP8-542

Delivery in unassembled individual components.

*Only with cover plate, hexagon screws and locking washers.

Tube clamps series C (Heavy series) – Components

DIN 3015, part 2

Order code for clamp halves:

Polypropylene – **RCP**
 Inside smooth – **RCPG**¹⁾
 Polyamide 6 – **RCN**¹⁾
 Rubber – **RCVR**
 Aluminium – **RCA**

(Please exchange as required standard abbreviation RCP in column for "clamp halves")

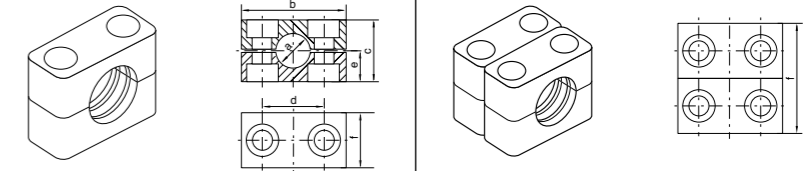

RCPD
(= 2XRCP...)

clamp size	Tube O.D. mm	Tube NB	Tube O.D.	1 part 2 clamp halves						1 part 4 clamp halves					
				RCP... Order code	dimensions:					RCPD... Order code	dimensions:				
1	6	G 1/8	5/16	RCP106X	55	32	33	16	30	RCPD106	55	32	33	16	60
	8			RCP108X						RCPD108					
	10			RCP110X						RCPD110					
	12			RCP112X						RCPD112					
	12.7			RCP112.7X						RCPD112.7					
	13.5			RCP113.5X						RCPD113.5					
	14			RCP114X						RCPD114					
	15			RCP115X						RCPD115					
	16			RCP116X						RCPD116					
	17.2			RCP117.2X						RCPD117.2					
	18			RCP118X						RCPD118					
	2			19						G 1/2					
20		RCP220X	RCPD220												
21.3		RCP221.3X	RCPD221.3												
22		RCP222X	RCPD222												
23		RCP223X	RCPD223												
25		RCP225X	RCPD225												
26.9		RCP226.9X	RCPD226.9												
28		RCP228X	RCPD228												
30		RCP230X	RCPD230												
3		30	G 1	1 1/4	RCP330X	85	60	60	30		30	RCPD330	85	60	60
	32	RCP332X			RCPD332										
	33.7	RCP333.7X			RCPD333.7										
	35	RCP335X			RCPD335										
	38	RCP338X			RCPD338										
	40	RCP340X			RCPD340										
	42	RCP342X			RCPD342										
4	38	G 1 1/4	1 1/2	RCP438X	115	90	90	45	45	RCPD438	115	90	90	45	90
	40			RCP440X						RCPD440					
	42			RCP442X						RCPD442					
	45			RCP445X						RCPD445					
	48.3			RCP448.3X						RCPD448.3					
	50			RCP450X						RCPD450					
	51			RCP451X						RCPD451					
	52			RCP452X						RCPD452					
	55			RCP455X						RCPD455					
	57			RCP457X						RCPD457					
	60.3			RCP460.3X						RCPD460.3					
	63			RCP463X						RCPD463					
	65			RCP465X						RCPD465					
	70			RCP470X						RCPD470					

Continuation see next page ...

Tube clamps series C (Heavy series) – Components (Continued)

Order code for clamp halves:

- Polypropylene – RCP
- Inside smooth – RCPG¹⁾
- Polyamide 6 – RCN¹⁾
- Rubber – RCVR
- Aluminium – RCA

(Please exchange as required standard abbreviation RCP in column for “clamp halves”)

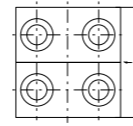
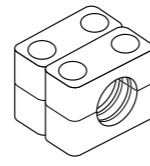
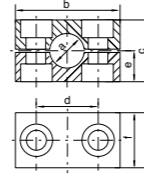
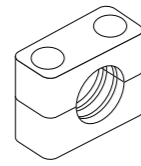

RCPD
(= 2XRCP...)

clamp size	Tube O.D. mm	Tube NB	Tube O.D.	1 part 2 clamp halves					1 part 4 clamp halves						
				RCP... Order code	dimensions: b c d e f					RCPD... Order code	dimensions: b c d e f				
5	70	G 2½	3	RCP570X	152	120	122	60	60	RCPD570	152	120	122	60	120
	73			RCP573X						RCPD573					
	75			RCP575X						RCPD575					
	76.1	RCP576.1X	RCPD576.1												
	80	RCP580X	RCPD580												
	82.5	RCP582.5X	RCPD582.5												
88.9	RCP588.9X	RCPD588.9													
90	RCP590X	RCPD590													
6	90	G 3½	4	RCP690X	205	170	168	85	80	RCPD690	205	170	168	85	160
	97			RCP697X						RCPD697					
	100			RCP6100X						RCPD6100					
	101.6	RCP6101.6X	RCPD6101.6												
	108	RCP6108X	RCPD6108												
	114.3	RCP6114.3X	RCPD6114.3												
127	RCP6127X	RCPD6127													
7	127	G 5	5	RCP7127X	250	200	205	100	90	RCPD7127	250	200	205	100	180
	133			RCP7133X						RCPD7133					
	140			RCP7140X						RCPD7140					
	150	RCP7150X	RCPD7150												
	152.4	RCP7152.4X	RCPD7152.4												
	159	RCP7159X	RCPD7159												
165.1	RCP7165.1X	RCPD7165.1													
168.3	RCP7168.3X	RCPD7168.3													
8	168.3	G 8	6 5/8	RCP8168.3X	320	270	265	135	120	RCPD8168.3	320	270	265	135	240
	177.8			RCP8177.8X						RCPD8177.8					
	193.7			RCP8193.7X						RCPD8193.7					
	203	RCP8203X	RCPD8203												
	219.1	RCP8219.1X	RCPD8219.1												
	220	RCP8220X	RCPD8220												

Metal parts also available in stainless steel.
1) Only sizes 1–4

Tube clamps series C (Heavy series) – Components

DIN 3015, part 2

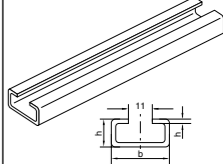
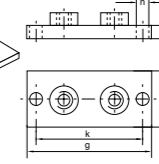
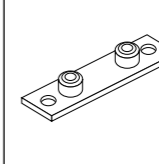
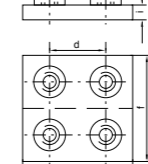
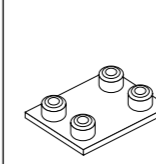
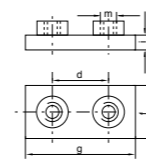
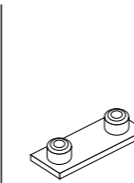

clamp size	AP C... Order code	weld plate dimensions:					APD C... Order code	double weld plate dimensions:					APL C... Order code	weld/screw plate dimensions:					mounting rail dim.:	
		d	f	g	i	m		d	f	g	i	m		g	f	i	k	n	TSC... Order code	b h
1	APC1X	33	30	73	8	M10	APDC1X	33	60	73	8	M10	APLC1X	113	30	8	85	11	TSC1X (1 Meter)	40 22
2	APC2X	45	30	85	8	M10	APDC2X	45	60	85	8	M10	APLC2X	125	30	8	97	11		
3	APC3X	60	30	100	8	M10	APDC3X	60	60	100	8	M10	APLC3X	140	30	8	112	11	TSC2X (2 Meter)	
4	APC4X	90	45	140	10	M12	APDC4X	90	90	140	10	M12	APLC4X	190	45	10	160	14		
5	APC5X	122	60	180	10	M16	APDC5X	122	120	180	10	M16	APLC5X	240	60	10	205	18		
6	APC6X	168	80	225	15	M20	APDC6X	168	160	225	15	M20	APLC6X	310	80	15	270	22		
7	APC7X	205	90	270	15	M24	APDC7X	205	180	270	15	M24	APLC7X	370	90	15	320	26		
8	APC8X	265	120	340	25	M30	APDC8X	265	240	340	25	M30	APLC8X	450	120	25	390	33		

Metal parts also available in stainless steel.
Complete programme range please refer to page 84.

Tube clamps series C (Heavy series) – Components

DIN 3015, part 2

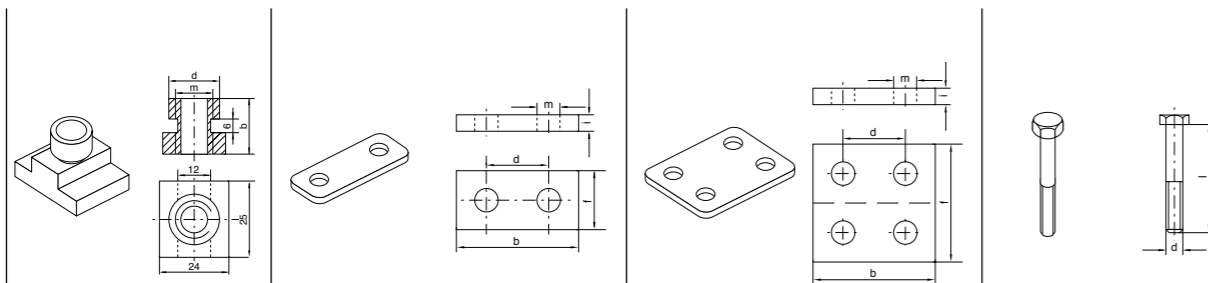

clamp size	rail nut		cover plate					double cover plate					hexagon head			
	TM C... Order code	dimensions: b d m	DP C... Order code	b	d	f	i	m	DPDC C... Order code	b	d	f	i	m	SS C... Order code	dimensions: d x L
1	TMC1X	20 17.8 M10	DPC1X	55	33	30	8	11	DPDC1X	55	33	60	8	11	SSC1X	M 10 x 45
2			DPC2X	70	45	30	8	11	DPDC2X	70	45	60	8	11	SSC2X	M 10 x 60
3			DPC3X	85	60	30	8	11	DPDC3X	85	60	60	8	11	SSC3X	M 10 x 70
4	TMC4X	23 19.8 M12	DPC4X	115	90	45	10	14	DPDC4X	115	90	90	10	14	SSC4X	M 12 x 100
5			DPC5X	152	122	60	10	18	DPDC5X	152	122	120	10	18	SSC5X	M 16 x 130
6			DPC6X	205	168	80	15	22	DPDC6X	205	168	160	15	22	SSC6X	M 20 x 190
7			DPC7X	250	205	90	15	26	DPDC7X	250	205	180	15	26	SSC7X	M 24 x 220
8			DPC8X	320	265	120	25	33	DPDC8X	320	265	240	25	33	SSC8X	M 30 x 300

Metal parts also available in stainless steel.

Tube clamps series C (Heavy series) – Components

DIN 3015, part 2

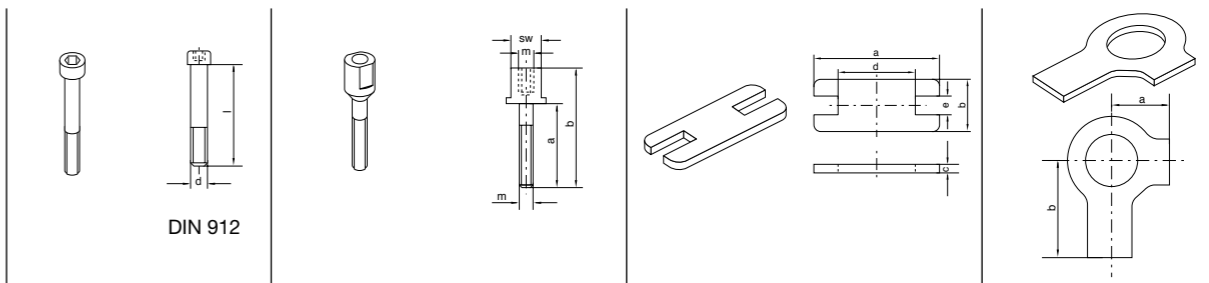

clamp size	socket head		stacking				locking plate ¹⁾					locking washer ²⁾			
	IS C... Order code	dimensions: d x L	AS C... Order code	a	b	m	SW	SP C... Order code	a	b	c	d	e	US C... Order code	dimensions: a b
1	ISC1X	M 10 x 45	ASC1X	25	51	M 10	15	SPC1X	55	30	8	14	15.5	USC1X	13 22
2	ISC2X	M 10 x 60	ASC2X	40	66	M 10	15	SPC2X	70	30	8	26	15.5		
3	ISC3X	M 10 x 70	ASC3X	50	76	M 10	15	SPC3X	85	30	8	41	15.5		
4	ISC4X	M 12 x 100	ASC4X	85	112	M 12	17	SPC4X	115	45	10	69	17.5	USC4X	15 28
5	ISC5X	M 16 x 130	ASC5X	110	146	M 16	21	SPC5X	152	60	10	97	21.5	USC5X	18 32
6	ISC6X	M 20 x 190	ASC6X	155	206	M 20	27	SPC6X	205	80	15	137	27.5	USC6X	21 36
7	ISC7X	M 24 x 220	ASC7X	185	245	M 24	30	SPC7X	250	90	15	169	30.5	USC7X	25 42
8	ISC8X	M 30 x 300	ASC8X	250	330	M 30	36	SPC8X	320	120	25	219	36.5	USC8X	32 52

¹⁾ The use of stacking screws necessitates the use of locking plates in the construction assembly!

²⁾ When assembling solid rubber clamps, covering plates, hexagon screws and locking washers must be used. Metal parts also available in stainless steel.

Tube clamps series C – Complete range

Polypropylene – RCP
 Inside smooth – RCPG¹⁾
 Polyamide 6 – RCN
 Rubber – RCVR*
 Aluminium – RCA

(As required please exchange standard abbreviation RCP in column for "Order code")

2 clamp halves, weld plate, cover plate, hex. head bolt

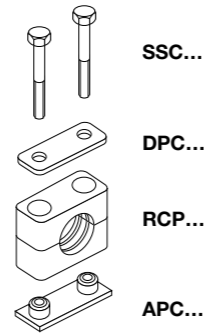

2 clamp halves, weld plate, cover plate, socket head bolt

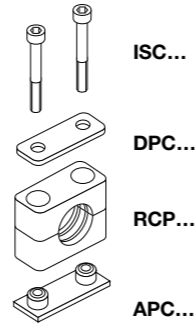

clamp size	Tube O.D. mm	Tube NB	Tube O.D.	Order code	Order code
1	6	G 1/8	5/16	RCP1-106	RCP2-106
	8			RCP1-108	RCP2-108
	10			RCP1-110	RCP2-110
	12	G 1/4	1/2	RCP1-112	RCP2-112
	12.7			RCP1-112.7	RCP2-112.7
	13.5			RCP1-113.5	RCP2-113.5
	14			RCP1-114	RCP2-114
	15	G 3/8	5/8	RCP1-115	RCP2-115
	16			RCP1-116	RCP2-116
	17.2			RCP1-117.2	RCP2-117.2
18	RCP1-118			RCP2-118	
2	19	G 1/2	3/4	RCP1-219	RCP2-219
	20			RCP1-220	RCP2-220
	21.3			RCP1-221.3	RCP2-221.3
	22			RCP1-222	RCP2-222
	23	G 3/4	1	RCP1-223	RCP2-223
	25			RCP1-225	RCP2-225
	26.9			RCP1-226.9	RCP2-226.9
	28			RCP1-228	RCP2-228
	30			RCP1-230	RCP2-230
	30			G 1	1 1/4
32	RCP1-332	RCP2-332			
33.7	RCP1-333.7	RCP2-333.7			
35	RCP1-335	RCP2-335			
3	38	G 1 1/4	1 1/2	RCP1-338	RCP2-338
	40			RCP1-340	RCP2-340
	42			RCP1-342	RCP2-342
	38			G 2	2 1/4
	40	RCP1-440	RCP2-440		
	4	42	G 1 1/4	1 1/2	RCP1-442
45		RCP1-445			RCP2-445
48.3		RCP1-448.3			RCP2-448.3
50		RCP1-450			RCP2-450
51		G 1 1/2	2	RCP1-451	RCP2-451
52				RCP1-452	RCP2-452
55				RCP1-455	RCP2-455
57				RCP1-457	RCP2-457
60.3		G 2	2 1/4	RCP1-460.3	RCP2-460.3
63				RCP1-463	RCP2-463
65				RCP1-465	RCP2-465
70				RCP1-470	RCP2-470

Continuation see next page ...



Tube clamps series C – Complete range (Continued)

Polypropylene – RCP
 Inside smooth – RCPG¹⁾
 Polyamide 6 – RCN
 Rubber – RCVR*
 Aluminium – RCA

(As required please exchange standard abbreviation RCP in column for "Order code")

2 clamp halves, weld plate, cover plate, hex. head bolt

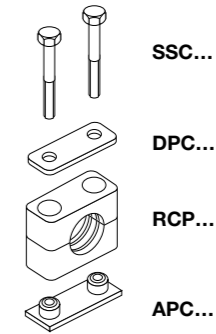

2 clamp halves, weld plate, cover plate, socket head bolt

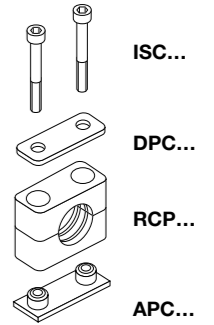

clamp size	Tube O.D. mm	Tube NB	Tube O.D.	Order code	Order code		
5	70	G 2 1/2	3	RCP1-570	RCP2-570		
	73			RCP1-573	RCP2-573		
	75			RCP1-575	RCP2-575		
	76.1			RCP1-576.1	RCP2-576.1		
	80	G 3	3 1/4	RCP1-580	RCP2-580		
	82.5			RCP1-582.5	RCP2-582.5		
	88.9			RCP1-588.9	RCP2-588.9		
	90			RCP1-590	RCP2-590		
	90			G 3 1/2	4	RCP1-690	RCP2-690
	97					RCP1-697	RCP2-697
100	RCP1-6100	RCP2-6100					
101.6	RCP1-6101.6	RCP2-6101.6					
6	108	G 4	4 1/4	RCP1-6108	RCP2-6108		
	114.3			RCP1-6114.3	RCP2-6114.3		
	127	G 5	5	RCP1-6127	RCP2-6127		
	127			RCP1-7127	RCP2-7127		
	133			RCP1-7133	RCP2-7133		
	140			RCP1-7140	RCP2-7140		
	150			RCP1-7150	RCP2-7150		
	152.4			RCP1-7152.4	RCP2-7152.4		
	159			RCP1-7159	RCP2-7159		
	165.1			RCP1-7165.1	RCP2-7165.1		
7	168.3	G 6	6 1/4	RCP1-7168.3	RCP2-7168.3		
	168.3			RCP1-8168.3	RCP2-8168.3		
	177.8			RCP1-8177.8	RCP2-8177.8		
	193.7			RCP1-8193.7	RCP2-8193.7		
	203	G 8	7 5/8	RCP1-8203	RCP2-8203		
	219.1			RCP1-8219.1	RCP2-8219.1		
	220			RCP1-8220	RCP2-8220		

Delivery in unassembled individual components.

¹⁾ Only sizes 1-4

* Only with cover plate, hexagon screws and locking washers (only sizes 1-4).

Tube clamps series C – Complete range

Polypropylene – RCP
 Inside smooth – RCPG¹⁾
 Polyamide 6 – RCN
 Rubber – RCVR*
 Aluminium – RCA

(As required please exchange standard abbreviation RCP in column for "Order code")

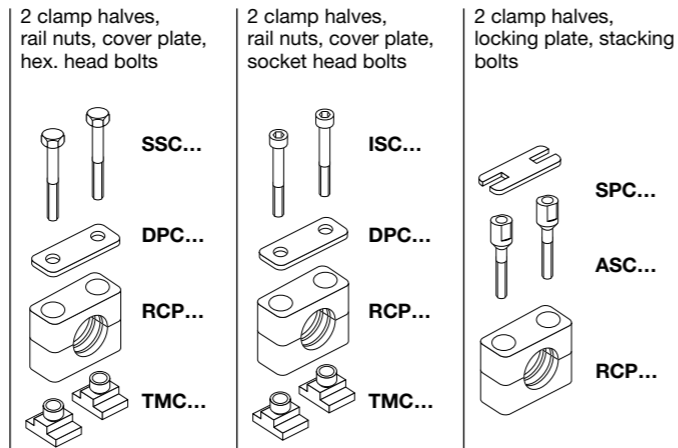

clamp size	Tube O.D. mm	Tube NB	Tube O.D.	Order code	Order code	Order code		
1	6	G 1/8	5/16	RCP3-106	RCP4-106	RCP5-106		
	8			RCP3-108	RCP4-108	RCP5-108		
	10			RCP3-110	RCP4-110	RCP5-110		
	12	G 1/4	1/2	RCP3-112	RCP4-112	RCP5-112		
	12.7			RCP3-112.7	RCP4-112.7	RCP5-112.7		
	13.5			RCP3-113.5	RCP4-113.5	RCP5-113.5		
	14			RCP3-114	RCP4-114	RCP5-114		
	15	G 3/8	5/8	RCP3-115	RCP4-115	RCP5-115		
	16			RCP3-116	RCP4-116	RCP5-116		
	17.2			RCP3-117.2	RCP4-117.2	RCP5-117.2		
18	RCP3-118			RCP4-118	RCP5-118			
2	19	G 1/2	3/4	RCP3-219	RCP4-219	RCP5-219		
	20			RCP3-220	RCP4-220	RCP5-220		
	21.3			RCP3-221.3	RCP4-221.3	RCP5-221.3		
	22			RCP3-222	RCP4-222	RCP5-222		
	23	G 3/4	1	RCP3-223	RCP4-223	RCP5-223		
	25			RCP3-225	RCP4-225	RCP5-225		
	26.9			RCP3-226.9	RCP4-226.9	RCP5-226.9		
	28			RCP3-228	RCP4-228	RCP5-228		
	30			RCP3-230	RCP4-230	RCP5-230		
	30			G 1	1 1/4	RCP3-330	RCP4-330	RCP5-330
32	RCP3-332	RCP4-332	RCP5-332					
33.7	RCP3-333.7	RCP4-333.7	RCP5-333.7					
35	RCP3-335	RCP4-335	RCP5-335					
38	RCP3-338	RCP4-338	RCP5-338					
3	40	G 1 1/4	1 1/2	RCP3-340	RCP4-340	RCP5-340		
	42			RCP3-342	RCP4-342	RCP5-342		
	38			G 1 1/4	1 1/2	RCP3-438	RCP4-438	RCP5-438
	40					RCP3-440	RCP4-440	RCP5-440
	42					RCP3-442	RCP4-442	RCP5-442
	45					RCP3-445	RCP4-445	RCP5-445
48.3	RCP3-448.3	RCP4-448.3	RCP5-448.3					
50	RCP3-450	RCP4-450	RCP5-450					
51	G 1 1/2	2	RCP3-451			RCP4-451	RCP5-451	
52			RCP3-452			RCP4-452	RCP5-452	
55			RCP3-455			RCP4-455	RCP5-455	
57			RCP3-457			RCP4-457	RCP5-457	
4	60.3	G 2	2 1/4	RCP3-460.3	RCP4-460.3	RCP5-460.3		
	63			RCP3-463	RCP4-463	RCP5-463		
	65			RCP3-465	RCP4-465	RCP5-465		
	70			RCP3-470	RCP4-470	RCP5-470		
	70			G 2	2 1/2	RCP3-463	RCP4-463	RCP5-463
70	RCP3-465	RCP4-465	RCP5-465					

Continuation see next page ...



Tube clamps series C – Complete range (Continued)

Polypropylene – RCP
 Inside smooth – RCPG¹⁾
 Polyamide 6 – RCN
 Rubber – RCVR*
 Aluminium – RCA

(As required please exchange standard abbreviation RCP in column for "Order code")

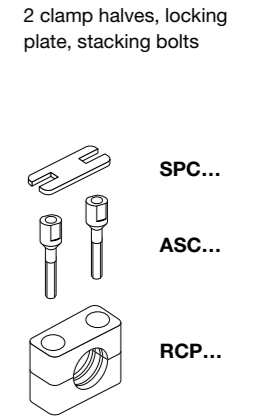

clamp size	Tube O.D. mm	Tube NB	Tube O.D.	Order code			
5	70	G 2 1/2	3	RCP5-570			
	73			RCP5-573			
	75			RCP5-575			
	76.1			RCP5-576.1			
	80			RCP5-580			
	82.5			RCP5-582.5			
	88.9			RCP5-588.9			
	90			RCP5-590			
	6			90	G 3 1/2	4	RCP5-690
				97			RCP5-697
100		RCP5-6100					
101.6		RCP5-6101.6					
108		RCP5-6108					
114.3		RCP5-6114.3					
7	127	G 5	5	RCP5-6127			
	127			RCP5-7127			
	133			RCP5-7133			
	140			RCP5-7140			
	150			RCP5-7150			
	152.4			RCP5-7152.4			
	159			RCP5-7159			
	165.1			RCP5-7165.1			
	168.3			RCP5-7168.3			
	8			168.3	G 6	6	RCP5-8168.3
177.8		RCP5-8177.8					
193.7		RCP5-8193.7					
203		RCP5-8203					
219.1		RCP5-8219.1					
220		RCP5-8220					
8		G 8	8 5/8	RCP5-8168.3			
				RCP5-8177.8			

Delivery in unassembled individual components.

¹⁾ Only sizes 1-4

* Only with cover plate, hexagon screws and locking washers (only sizes 1-4).

Tube clamps series C – Complete range

Polypropylene – RCPD
 Inside smooth – RCPDG¹⁾
 Polyamide 6 – RCND
 Rubber – RCVDR*
 Aluminium – RCAD

(As required please exchange standard abbreviation RCP in column for "Order code")

4 clamp halves, double weld plate, double cover plate, hex. head bolts

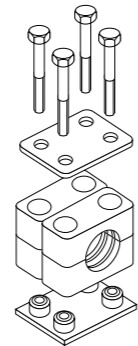

SSC...
 DPDC...
 RCPD...
 (=2XRCP...)
 APDC...

4 clamp halves, double weld plate, double cover plate, socket head bolts

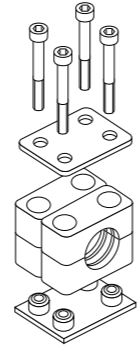

ISC...
 DPDC...
 RCPD...
 (=2XRCP...)
 APDC...

clamp size	Tube O.D. mm	Tube NB	Tube O.D.	Order code	Order code
1	6	G 1/8	5/16	RCPD1-106	RCPD2-106
	8			RCPD1-108	RCPD2-108
	10			RCPD1-110	RCPD2-110
	12			RCPD1-112	RCPD2-112
	12.7	G 1/4	1/2	RCPD1-112.7	RCPD2-112.7
	13.5			RCPD1-113.5	RCPD2-113.5
	14			RCPD1-114	RCPD2-114
	15			RCPD1-115	RCPD2-115
	16	G 3/8	5/8	RCPD1-116	RCPD2-116
	17.2			RCPD1-117.2	RCPD2-117.2
18	RCPD1-118			RCPD2-118	
2	19			G 1/2	3/4
	20	RCPD1-220	RCPD2-220		
	21.3	RCPD1-221.3	RCPD2-221.3		
	22	RCPD1-222	RCPD2-222		
	23	G 3/4	1	RCPD1-223	RCPD2-223
	25			RCPD1-225	RCPD2-225
	26.9			RCPD1-226.9	RCPD2-226.9
	28			RCPD1-228	RCPD2-228
	30	RCPD1-230	RCPD2-230		
	3	30	G 1	1 1/4	RCPD1-330
32		RCPD1-332			RCPD2-332
33.7		RCPD1-333.7			RCPD2-333.7
35		RCPD1-335			RCPD2-335
38		G 1 1/4	1 1/2	RCPD1-338	RCPD2-338
40				RCPD1-340	RCPD2-340
42				RCPD1-342	RCPD2-342
4				38	G 1 1/4
	40	RCPD1-440	RCPD2-440		
	42	RCPD1-442	RCPD2-442		
	45	RCPD1-445	RCPD2-445		
	48.3	G 1 1/2	2	RCPD1-448.3	RCPD2-448.3
	50			RCPD1-450	RCPD2-450
	51			RCPD1-451	RCPD2-451
	52			RCPD1-452	RCPD2-452
	55	G 2	2 1/4	RCPD1-455	RCPD2-455
	57			RCPD1-457	RCPD2-457
	60.3			RCPD1-460.3	RCPD2-460.3
	63			RCPD1-463	RCPD2-463
65	2 1/2	2 1/2	RCPD1-465	RCPD2-465	
70			RCPD1-470	RCPD2-470	

Continuation see next page ...



Tube clamps series C – Complete range (Continued)

Polypropylene – RCPD
 Inside smooth – RCPDG¹⁾
 Polyamide 6 – RCND
 Rubber – RCVDR*
 Aluminium – RCAD

(As required please exchange standard abbreviation RCP in column for "Order code")

4 clamp halves, double weld plate, double cover plate, hex. head bolts

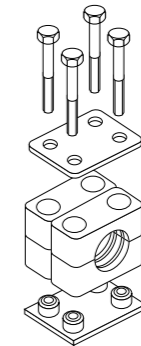

SSC...
 DPDC...
 RCPD...
 (=2XRCP...)
 APDC...

4 clamp halves, double weld plate, double cover plate, socket head bolts

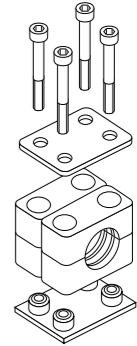

ISC...
 DPDC...
 RCPD...
 (=2XRCP...)
 APDC...

clamp size	Tube O.D. mm	Tube NB	Tube O.D.	Order code	Order code	
5	70	G 2 1/2	3	RCPD1-570	RCPD2-570	
	73			RCPD1-573	RCPD2-573	
	75			RCPD1-575	RCPD2-575	
	76.1			RCPD1-576.1	RCPD2-576.1	
	80	G 3	3 1/4	RCPD1-580	RCPD2-580	
	82.5			RCPD1-582.5	RCPD2-582.5	
	88.9			RCPD1-588.9	RCPD2-588.9	
	90			RCPD1-590	RCPD2-590	
	6	90	G 3 1/2	4	RCPD1-690	RCPD2-690
		97			RCPD1-697	RCPD2-697
100		RCPD1-6100			RCPD2-6100	
101.6		G 4	4 1/4	RCPD1-6101.6	RCPD2-6101.6	
108				RCPD1-6108	RCPD2-6108	
114.3				RCPD1-6114.3	RCPD2-6114.3	
7	127	G 5	5	RCPD1-6127	RCPD2-6127	
	133			RCPD1-7133	RCPD2-7133	
	140			RCPD1-7140	RCPD2-7140	
	150			RCPD1-7150	RCPD2-7150	
	152.4	G 6	6	RCPD1-7152.4	RCPD2-7152.4	
	159			RCPD1-7159	RCPD2-7159	
	165.1			RCPD1-7165.1	RCPD2-7165.1	
	168.3			RCPD1-7168.3	RCPD2-7168.3	
8	168.3	G 8	6 5/8	RCPD1-8168.3	RCPD2-8168.3	
	177.8			RCPD1-8177.8	RCPD2-8177.8	
	193.7	7 5/8	7	RCPD1-8193.7	RCPD2-8193.7	
	203			RCPD1-8203	RCPD2-8203	
	219.1			RCPD1-8219.1	RCPD2-8219.1	
	220			RCPD1-8220	RCPD2-8220	

Delivery in unassembled individual components.

¹⁾ Only sizes 1-4

* Only with cover plate, hexagon screws and locking washers (only sizes 1-4).

Tube clamp series C with absorbing noise insert

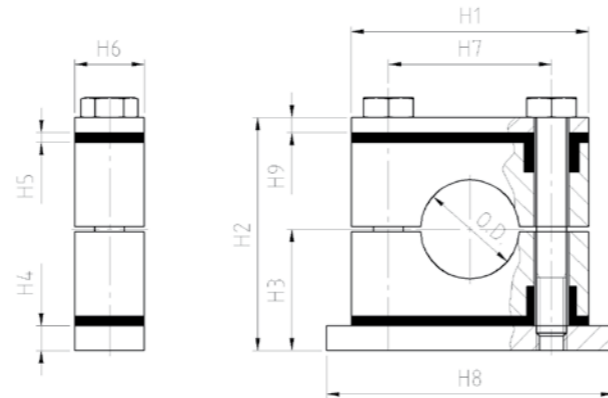

Clamp size	Tube O.D.mm	Absorbing plate	Weld plate	Bolt ISO 4014	H1	H2	H3	H4	H5	H6	H7	H8	H9
1	6.0	DPEC1X	APCD1X	M10X65	55	69	38	15	7	30	33	70	8
	8.0												
	9.5												
	10.0												
	12.0												
	12.7												
	13.5												
	14.0												
	15.0												
	16.0												
17.2													
18.0													
2	19.0	DPEC2X	APCD2X	M10X80	70	85	46	15	7	30	45	85	8
	20.0												
	21.3												
	22.0												
	23.0												
	25.0												
	26.9												
28.0													
30.0													
3	30.0	DPEC3X	APCD3X	M10X90	85	97	52	15	7	30	60	100	8
	32.0												
	33.7												
	35.0												
	38.0												
	40.0												
42.0													
4	38.0	DPEC4X	APCD4X	M12X130	115	134	72	20	7	45	90	140	10
	40.0												
	42.0												
	45.0												
	48.3												
	50.0												
	51.0												
	52.0												
	54.0												
	55.0												
	57.0												
	60.3												
	63.5												
	65.0												
70.0													



Tube clamp series C with absorbing noise insert

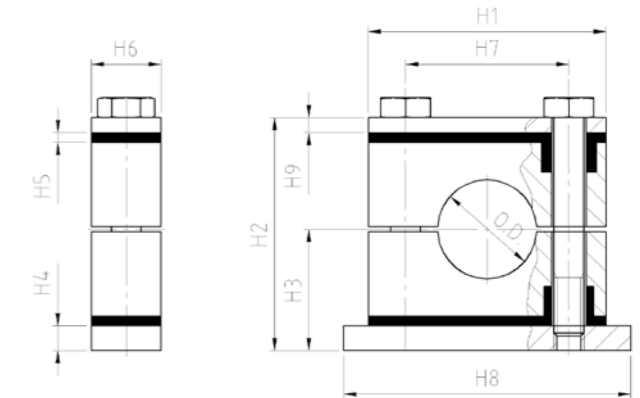

Clamp size	Tube O.D.mm	Absorbing plate	Weld plate	Bolt ISO 4014	H1	H2	H3	H4	H5	H6	H7	H8	H9
5	70.0	DPEC5X	APCD5X	M16X160	152	165	90	25	7	60	122	180	10
	73.0												
	75.0												
	76.1												
	80.0												
	82.5												
	88.9												
	90.0												
6	90.0	DPEC6X	APCD6X	M20X230	205	237	126	30	11	80	168	228	15
	97.0												
	100.0												
	101.6												
	108.0												
	114.3												
127.0													
7	127.0	DPEC7X	APCD7X	M24X260	250	287	161	50	11	90	205	270	15
	130.0												
	133.0												
	140.0												
	141.3												
	150.0												
	152.4												
	159.0												
165.1													
168.3													
8	168.3	DPEC8X	APCD8X	M30X360	322	407	231	80	16	120	265	340	25
	177.8												
	193.7												
	203.0												
	219.1												
220.0													



Tubes

Tube calculation

DIN 2413 I, only for static load

Calculation of working pressure of steel tubes for static stress up to 120 °C. Corrosion – additional allowances are not considered for the calculation of pressures. Tubes with a diameter of OD/ID > 2 are calculated for static stress in accordance with DIN 2413 III, but with K = yield strength.

Formula:

$$P = \frac{20 \times K \times s \times c}{S \times D}$$

- P = permissible working pressure [bar]
- K = yield strength [N/mm²]
- s = tube wall thickness [mm]
- c = factor for wall thickness allowance
= 0.8 for Tube-OD 4 – 5, 0.85 for Tube-OD 6 – 8, 0.9 for Tube-OD 10 – 140
= 0.9 for all stainless steel tubes
- S = Design factor = 1.5
- D = tube outside diameter [mm]

DIN 2413 III, for dynamic load

Calculation of working pressure of steel tubes for dynamic stress up to 120 °C. Corrosion – additional allowances are not considered for the calculation of pressures.

Formula

$$P = \frac{20 \times K \times s \times c}{S \times (D + s \times c)}$$

- P = permissible working pressure [bar]
- K = fatigue strength [N/mm²]
- s = tube wall thickness [mm]
- c = factor for wall thickness allowance
= 0.8 for Tube-OD 4 – 5, 0.85 for Tube-OD 6 – 8, 0.9 for Tube-OD 10 – 80
= 0.9 for all stainless steel tubes
- S = Design factor = 1.5
- D = tube outside diameter [mm]

Material specifications

E355 (St52.4) acc. to DIN EN 10305-4	
Tensile strength	min 490 N/mm ²
Yield strength	min 355 N/mm ²
Fatigue strength	265 N/mm ² ²⁾
Elongation at break	min. 22 %

1.4571 cold drawn (CFA) acc. to DIN EN 10216-5 (316Ti)	
Tensile strength	min 500 N/mm ²
0.2% proof stress	min 210 N/mm ²
1% proof stress	min 245 N/mm ²
Fatigue strength	220 N/mm ² ³⁾
Elongation at break	min. 35 %

²⁾ mhp statement 1996
³⁾ Rollof/Matek ME Ausg. 14, (no standard specification)



Seamless steel tubes

Material E355N (St. 52.4NBK)

Working pressure table acc. to DIN 2413-I and DIN 2413-III
Tolerances DIN EN 10305-4 (old DIN 2391) and ISO 3304
Tube calculation basics see left

Tube	P [bar]		Weight kg/m	Order code	
	DIN 2413 I	DIN 2413 III		Cr(VI)-free	Phosphated and oiled
25x3.0	511	344	1.63	R25X3.0ST52CF	R25X3.0ST52
25x4.0	682	445	2.07	R25X4.0ST52CF	R25X4.0ST52
30x4.0	568	379	2.57	R30X4.0ST52CF	R30X4.0ST52
30x5.0	710	461	3.08	R30X5.0ST52CF	R30X5.0ST52
38x4.0	448	306	3.35	R38X4.0ST52CF	R38X4.0ST52
38x5.0	561	374	4.07	R38X5.0ST52CF	R38X5.0ST52
38x6.0	673	440	4.74	R38X6.0ST52CF	R38X6.0ST52
42x5.0	507	342	4.56	R42X5.0ST52CF	R42X5.0ST52
50x3.0	256	181	3.48	R50X3.0ST52CF	R50X3.0ST52
50x5.0	426	292	5.55	R50X5.0ST52CF	R50X5.0ST52
50x6.0	511	344	6.51	R50X6.0ST52CF	R50X6.0ST52
50x8.0	682	445	8.29	R50X8.0ST52CF	R50X8.0ST52
60x8.0	568	379	10.26	R60X8.0ST52CF	R60X8.0ST52
65x8.0	524	352	11.25	R65X8.0ST52CF	R65X8.0ST52
66x8.5	549	367	12.05	R66X8.5ST52CF	R66X8.5ST52
75x12.5	710	461	19.27	R75X12.5ST52CF	R75X12.5ST52
80x3.0	160	115	5.70	R80X3.0ST52CF	R80X3.0ST52
80x8.0	426	292	14.21	R80X8.0ST52CF	R80X8.0ST52
80x10.0	533	357	17.26	R80X10.0ST52CF	R80X10.0ST52
88x14.0	678	443	25.55	R88X14.0ST52CF	R88X14.0ST52

Other dimensions on request

Parker's Motion & Control Technologies

At Parker, we're guided by a relentless drive to help our customers become more productive and achieve higher levels of profitability by engineering the best systems for their requirements. It means looking at customer applications from many angles to find new ways to create value. Whatever the motion or control technology need, Parker has the experience, breadth of product and global reach to consistently deliver. No company knows more about motion and control technology than Parker. For further information call 00800 27 27 5374



AEROSPACE

Key Markets

- Aircraft engines
- Business & general aviation
- Commercial transports
- Land-based weapons systems
- Military aircraft
- Missiles & launch vehicles
- Regional transports
- Unmanned aerial vehicles

Key Products

- Flight control systems & components
- Fluid conveyance systems
- Fluid metering delivery & atomization devices
- Fuel systems & components
- Hydraulic systems & components
- Inert nitrogen generating systems
- Pneumatic systems & components
- Wheels & brakes

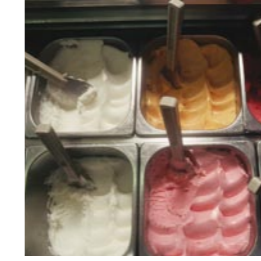

CLIMATE CONTROL

Key Markets

- Agriculture
- Air conditioning
- Food, beverage & dairy
- Life sciences & medical
- Precision cooling
- Processing
- Transportation

Key Products

- CO₂ controls
- Electronic controllers
- Filter driers
- Hand shut-off valves
- Hose & fittings
- Pressure regulating valves
- Refrigerant distributors
- Safety relief valves
- Solenoid valves
- Thermostatic expansion valves



ELECTROMECHANICAL

Key Markets

- Aerospace
- Factory automation
- Life science & medical
- Machine tools
- Packaging machinery
- Paper machinery
- Plastics machinery & converting
- Primary metals
- Semiconductor & electronics
- Textile
- Wire & cable

Key Products

- AC/DC drives & systems
- Electric actuators, gantry robots & slides
- Electrohydraulic actuation systems
- Electromechanical actuation systems
- Human machine interface
- Linear motors
- Stepper motors, servo motors, drives & controls
- Structural extrusions

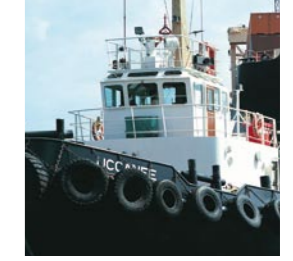

FILTRATION

Key Markets

- Food & beverage
- Industrial machinery
- Life sciences
- Marine
- Mobile equipment
- Oil & gas
- Power generation
- Process
- Transportation

Key Products

- Analytical gas generators
- Compressed air & gas filters
- Condition monitoring
- Engine air, fuel & oil filtration & systems
- Hydraulic, lubrication & coolant filters
- Process, chemical, water & microfiltration filters
- Nitrogen, hydrogen & zero air generators



FLUID & GAS HANDLING

Key Markets

- Aerospace
- Agriculture
- Bulk chemical handling
- Construction machinery
- Food & beverage
- Fuel & gas delivery
- Industrial machinery
- Mobile
- Oil & gas
- Transportation
- Welding

Key Products

- Brass fittings & valves
- Diagnostic equipment
- Fluid conveyance systems
- Industrial hose
- PTFE & PFA hose, tubing & plastic fittings
- Rubber & thermoplastic hose & couplings
- Tube fittings & adapters
- Quick disconnects



HYDRAULICS

Key Markets

- Aerospace
- Aerial lift
- Agriculture
- Construction machinery
- Forestry
- Industrial machinery
- Mining
- Oil & gas
- Power generation & energy
- Truck hydraulics

Key Products

- Diagnostic equipment
- Hydraulic cylinders & accumulators
- Hydraulic motors & pumps
- Hydraulic systems
- Hydraulic valves & controls
- Power take-offs
- Rubber & thermoplastic hose & couplings
- Tube fittings & adapters
- Quick disconnects

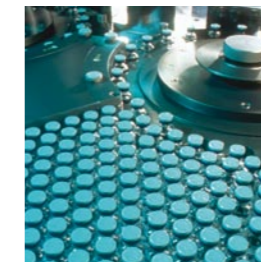

PNEUMATICS

Key Markets

- Aerospace
- Conveyor & material handling
- Factory automation
- Life science & medical
- Machine tools
- Packaging machinery
- Transportation & automotive

Key Products

- Air preparation
- Brass fittings & valves
- Manifolds
- Pneumatic accessories
- Pneumatic actuators & grippers
- Pneumatic valves & controls
- Quick disconnects
- Rotary actuators
- Rubber & thermoplastic hose & couplings
- Structural extrusions
- Thermoplastic tubing & fittings
- Vacuum generators, cups & sensors



PROCESS CONTROL

Key Markets

- Chemical & refining
- Food, beverage & dairy
- Medical & dental
- Microelectronics
- Oil & gas
- Power generation

Key Products

- Analytical sample conditioning products & systems
- Fluoropolymer chemical delivery fittings, valves & pumps
- High purity gas delivery fittings, valves & regulators
- Instrumentation fittings, valves & regulators
- Medium pressure fittings & valves
- Process control manifolds



SEALING & SHIELDING

Key Markets

- Aerospace
- Chemical processing
- Consumer
- Energy, oil & gas
- Fluid power
- General industrial
- Information technology
- Life sciences
- Military
- Semiconductor
- Telecommunications
- Transportation

Key Products

- Dynamic seals
- Elastomeric o-rings
- EMI shielding
- Extruded & precision-cut, fabricated elastomeric seals
- Homogeneous & inserted elastomeric shapes
- High temperature metal seals
- Metal & plastic retained composite seals
- Thermal management

Parker Worldwide

AE – UAE, Dubai
Tel: +971 4 8127100
parker.me@parker.com

AR – Argentina, Buenos Aires
Tel: +54 3327 44 4129

AT – Austria, Wiener Neustadt
Tel: +43 (0)2622 23501-0
parker.austria@parker.com

AT – Eastern Europe, Wiener Neustadt
Tel: +43 (0)2622 23501 970
parker.easteurope@parker.com

AU – Australia, Castle Hill
Tel: +61 (0)2-9634 7777

AZ – Azerbaijan, Baku
Tel: +994 50 2233 458
parker.azerbaijan@parker.com

BE/LU – Belgium, Nivelles
Tel: +32 (0)67 280 900
parker.belgium@parker.com

BR – Brazil, Cachoeirinha RS
Tel: +55 51 3470 9144

BY – Belarus, Minsk
Tel: +375 17 209 9399
parker.belarus@parker.com

CA – Canada, Milton, Ontario
Tel: +1 905 693 3000

CH – Switzerland, Etoy
Tel: +41 (0) 21 821 02 30
parker.switzerland@parker.com

CN – China, Shanghai
Tel: +86 21 5031 2525

CZ – Czech Republic, Klecany
Tel: +420 284 083 111
parker.czechrepublic@parker.com

DE – Germany, Kaarst
Tel: +49 (0)2131 4016 0
parker.germany@parker.com

DK – Denmark, Ballerup
Tel: +45 43 56 04 00
parker.denmark@parker.com

ES – Spain, Madrid
Tel: +34 902 33 00 01
parker.spain@parker.com

FI – Finland, Vantaa
Tel: +358 (0)20 753 2500
parker.finland@parker.com

FR – France, Contamine s/Arve
Tel: +33 (0)4 50 25 80 25
parker.france@parker.com

GR – Greece, Athens
Tel: +30 210 933 6450
parker.greece@parker.com

HK – Hong Kong
Tel: +852 2428 8008

HU – Hungary, Budapest
Tel: +36 1 220 4155
parker.hungary@parker.com

IE – Ireland, Dublin
Tel: +353 (0)1 466 6370
parker.ireland@parker.com

IN – India, Mumbai
Tel: +91 22 6513 7081-85

IT – Italy, Corsico (MI)
Tel: +39 02 45 19 21
parker.italy@parker.com

JP – Japan, Tokyo
Tel: +(81) 3 6408 3901

KR – South Korea, Seoul
Tel: +82 2 559 0400

KZ – Kazakhstan, Almaty
Tel: +7 7272 505 800
parker.easteurope@parker.com

LV – Latvia, Riga
Tel: +371 6 745 2601
parker.latvia@parker.com

MX – Mexico, Apodaca
Tel: +52 81 8156 6000

MY – Malaysia, Subang Jaya
Tel: +60 3 5638 1476

NL – The Netherlands, Oldenzaal
Tel: +31 (0)541 585 000
parker.nl@parker.com

NO – Norway, Ski
Tel: +47 64 91 10 00
parker.norway@parker.com

NZ – New Zealand, Mt Wellington
Tel: +64 9 574 1744

PL – Poland, Warsaw
Tel: +48 (0)22 573 24 00
parker.poland@parker.com

PT – Portugal, Leca da Palmeira
Tel: +351 22 999 7360
parker.portugal@parker.com

RO – Romania, Bucharest
Tel: +40 21 252 1382
parker.romania@parker.com

RU – Russia, Moscow
Tel: +7 495 645-2156
parker.russia@parker.com

SE – Sweden, Spånga
Tel: +46 (0)8 59 79 50 00
parker.sweden@parker.com

SG – Singapore
Tel: +65 6887 6300

SK – Slovakia, Banská Bystrica
Tel: +421 484 162 252
parker.slovakia@parker.com

SL – Slovenia, Novo Mesto
Tel: +386 7 337 6650
parker.slovenia@parker.com

TH – Thailand, Bangkok
Tel: +662 717 8140

TR – Turkey, Istanbul
Tel: +90 216 4997081
parker.turkey@parker.com

TW – Taiwan, Taipei
Tel: +886 2 2298 8987

UA – Ukraine, Kiev
Tel +380 44 494 2731
parker.ukraine@parker.com

UK – United Kingdom, Warwick
Tel: +44 (0)1926 317 878
parker.uk@parker.com

US – USA, Cleveland
Tel: +1 216 896 3000

VE – Venezuela, Caracas
Tel: +58 212 238 5422

ZA – South Africa, Kempton Park
Tel: +27 (0)11 961 0700
parker.southafrica@parker.com

European Product Information Centre

Free phone: 00 800 27 27 5374

(from AT, BE, CH, CZ, DE, EE, ES, FI, FR, IE, IT, PT, SE, SK, UK)

