



Quick Coupling Products Distribution

Catalogue 3800-DS/UK





For your safety!

Under certain circumstances, quick couplings can be subjected to extreme loadings such as vibration and uncontrolled pressure peaks.

Only by using genuine Parker Components and following Parker assembly instructions can you be assured of the reliability and safety of the product and their conformity to the applicable standards.

Failure to follow this rule can adversely affect the functional safety and reliability of products, cause personal injury, property damage, and result in loss of your guarantee rights.

Subject to alteration.

For your safety: see safety guide (pages 58-59)

All dimensions used in this catalogue are in mm otherwise the units are specified.
The rated pressure is in MPa.

If necessary you can also use the conversion table on page 60.

The products described herein, including without limitation, products features, dimensions, specifications and designs are subject to change by Parker Hannifin Corporation and its subsidiaries at any time without notice.

For the product availability of Parker components, please refer to price list 3893.

© Copyright 2004, revised 10/06, Parker Hannifin Corporation. All Right Reserved.

HYDRAULIC QUICK COUPLINGS

- How to select a quick coupling.....Page 02

INDUSTRIAL AND CHEMICAL

- ISO 7241-1-B quick couplings.....60 Series.....Page 04
- Flush-faced quick couplings female thread BSPP.....FEF Series.....Page 12
- ISO 16028 flush-faced quick couplings.....FEM Series.....Page 15
- Cooling flush-faced quick couplings.....NSI Series.....Page 19

HIGH PRESSURE

- High pressure quick couplings 150 MPa.....CM Series.....Page 21
- High pressure quick couplings 100 MPa.....CL Series.....Page 23
- High pressure screw type quick couplings 70 MPa.....3000 Series.....Page 25

MOBILE

- ISO 7241-1-A quick couplings female thread BSPP.....6600 Series.....Page 27
- ISO 7241-1-A quick couplings other threads.....2000 Series.....Page 30
- Rigid couplings.....9404 Series.....Page 35
- General purpose quick couplings.....4000 Series.....Page 38
- Screw type quick couplings.....QHPA Series.....Page 41
- Multicouplings 2 lines.....MACH 2.....Page 45
- Multicouplings 4 to 7 lines.....MACH System.....Page 48

APPENDICES











- Fluid compatibility chart.....Page 52
- Safety guide.....Page 58
- Conversion factors.....Page 60
- Alpha numeric index.....Page 63
- Parker Hannifin Corporation.....Page 65

Features	Series	Industrial and Chemical					High pressure			
		60 Series			FEF Series	FEM Series	NSI Series	CM Series	CL Series	3000 Series
		Brass	Steel	Stainless Steel						
Picture										
Standards		ISO 7241-1-B			Interchangeable with similar models	ISO 16028	Interchangeable with similar models	Interchangeable with similar models	Interchangeable with similar models	Interchangeable with similar models
Material		Brass	Steel	Stainless Steel						
		●	●		●	●	●	●	●	●
							and ●			
Size										
		●	●	●	●	●	●	●	●	●
		●	●	●	●	●	●	●	●	●
		●	●	●	●	●	●	●	●	●
		●	●	●	●	●	●	●	●	●
		●	●	●	●	●	●	●	●	●
		●	●	●	●	●	●	●	●	●
		●	●	●	●	●	●	●	●	●
		●	●	●	●	●	●	●	●	●
		●	●	●	●	●	●	●	●	●
		●	●	●	●	●	●	●	●	●
		●	●	●	●	●	●	●	●	●
Rated pressure* MPa										
		21.0	35.0	35.0						
		25.5	35.0	35.0	30	31.5	6.0	150	100	70
		18.5	28.0	35.0	30	25.0				70
		24.0	28.0	35.0	25	25.0				
					25	25.0				
		15.0	17.5	21.0	25	25.0				
		10.5	14.0	21.0	25	20.0				
		10.5	10.5	10.5						
		8.5	10.5							
Temperature range* (with NBR seal)		-40°C +110°C			-20°C +100°C	-20°C +100°C	-20°C +200°C	-30°C +100°C	-30°C +100°C	-30°C +110°C
Seal		NBR or FKM			NBR	NBR	FKM	NBR	NBR	NBR or Polyurethane
Coupler style			●					●	●	●
Valving			●		●	●	●	●	●	●
					●	●	●	●	●	●
										or ●
Connection possible with pressure on*										
Locking mechanism										●
End configuration		BSPP NPTF			BSPP	BSPP Metric	BSPP Metric	BSPP	BSPP	NPTF
Full technical data page		4			12	15	19	21	23	25

*Data shown here are indicative for quick selection purposes only. Please check technical data indicated for each individual series and always refer to safety guide pages 58-59.

Features	Series	Mobile						
		6600 Series	2000 Series	9404 Series	4000 Series	QHPA Series	MACH 2	MACH System
Picture								
Standards		ISO 7241-1-A	ISO 7241-1-A	ISO 7241-1-A	ISO 7241-1-A (1/2")	Interchangeable with similar models	ISO 7241-1-A	ISO 7241-1-A
Material								
	Brass							
	Steel	●	●	●	●	●	●	●
	Stainless Steel							
Size								
	1/8"							
	1/4"	●			●			
	3/8"	●	●		●	●		
	1/2"	●	●	●	●	●	●	●
	5/8"							
	3/4"	●			●	●		
	1"	●			●	●		
	1 1/2"							
	2 1/2"							
Rated pressure* MPa								
	1/8"							
	1/4"	35			20			
	3/8"	28	31.5		20	45.0		
	1/2"	28	25.0	25.0	20	40.0	25	25
	5/8"							
	3/4"	28			20	31.5		
	1"	28			20	20.0		
	1 1/2"							
	2 1/2"							
Temperature range* (with NBR seal)		-40°C +110°C	-25°C +110°C	-30°C +110°C	-40°C +110°C	-25°C +110°C	-30°C +110°C	-30°C +110°C
Seal		NBR	NBR	NBR	NBR	NBR	NBR	NBR
Coupler style								
	Manual	●			●		●	●
	Screw-to-connect					●		
	Push-Pull		●	●				
	Push-to-connect							
Valving								
	Poppet	●	●	●	●	●	●	●
	Flat-faced poppet							
	Ball		or ●		or ●			
Connection possible pressure on*								
	Female body					●	●	●
	Male tip			●		●	●	●
Locking mechanism								
	Screw type					●		
	With cam						●	●
	Ball locking mechanism	●	●	●	●			
End configuration		BSPP	BSPP, NPTF Metric	Metric UNF	BSPP NPTF	BSPP Metric	Metric	Metric
Full technical data page		27	30	35	38	41	45	48

*Data shown here are indicative for quick selection purposes only. Please check technical data indicated for each individual series and always refer to safety guide pages 58-59.

										
ISO 7241-1-B	Brass, steel, stainless steel 303 and 316	1/8", 1/4", 3/8", 1/2", 3/4", 1", 1 1/2", 2 1/2"	35 MPa	-40°C + 110°C (NBR seal) -20°C + 200°C (FKM seal : Viton™)	NBR (brass, steel, AISI 303 stainless steel), FKM (Viton™ AISI 316 stainless steel)	Manual	Poppet	No	Ball locking mechanism	BSPP, NPTF

Main characteristics

- Meets the requirements of **ISO 7241-1, Series B**
- Can be used for any type of industrial applications because of the broad range of materials, seals and end configurations

Applications

- Semiconductor industry, steel manufacturing
- Pneumatic and hydraulic hand tools
- Food and bottling industry
- Boating, shipbuilding and offshore industry
- Pharmaceutical industry, laboratories
- Transport
- Power generating plants, hydroelectric power stations (filling / connection of mobile filtration equipment)



Technical features

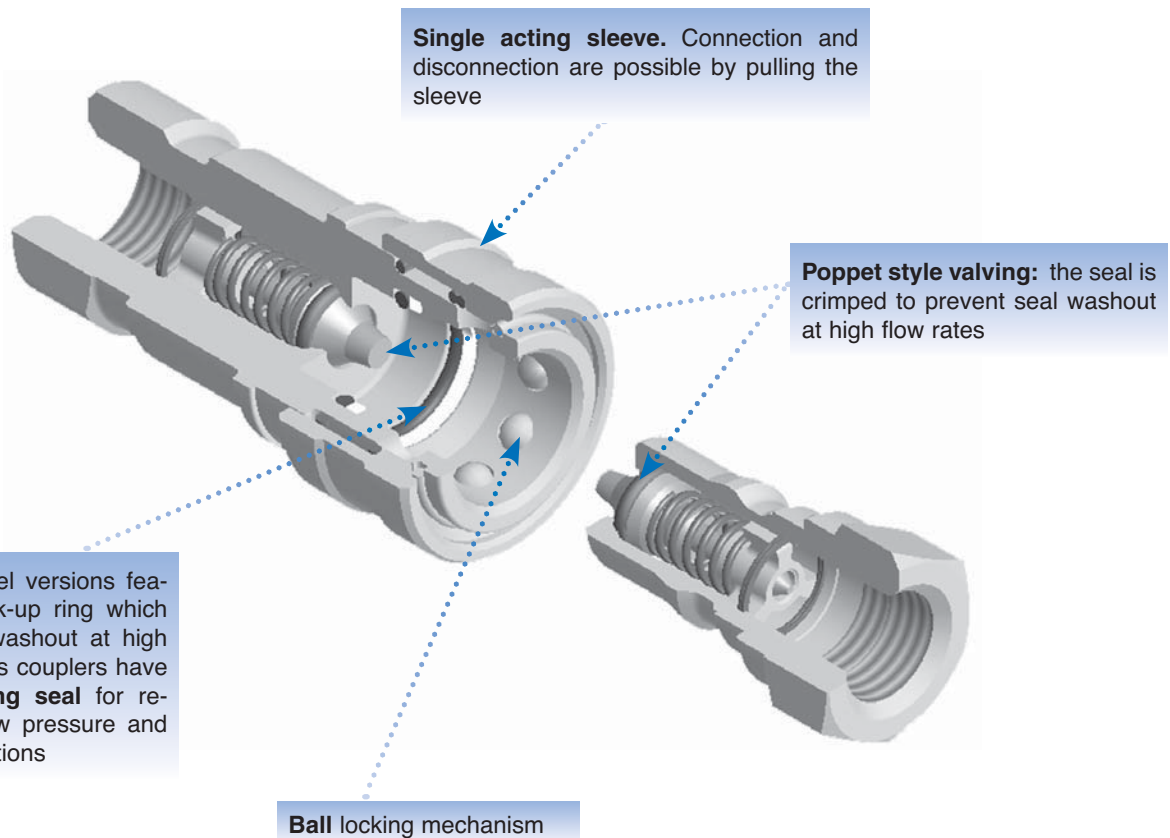

Technical performance data

Low cycle, non-pulsating pressure rating:

Applications with lower cycle time and no severe cyclic pressure fluctuations, essentially steady pressure during an operating cycle. Typical applications include hydraulic jacks, mine roof support systems, and high pressure fluid transfer (pumping water or slurry in oil wells). Minor pump ripple is considered non-pulsating. Impulse tested at rated pressure.

ANSI/ISO Pressure rating:

Dynamic applications with normal to moderate hydraulic shocks such as general industrial equipment, hydraulic presses, agricultural equipment. Impulse tested at a multiple (125 % or 133 %) of rated pressure. A uniform cycle rate of 0.5 to 1.0 Hz is held over 100,000 cycles according to ISO 7241-1 & 2.

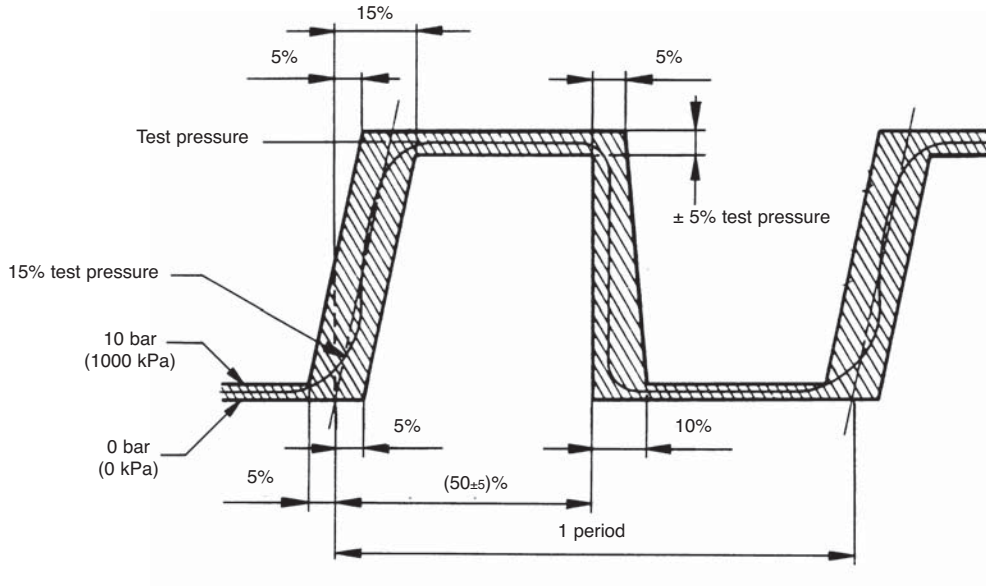

Body size inch	Low cycle, non-pulsating pressure rating MPa		
	Steel	Stainless steel	Brass
1/8"	35.0	35.0	21.0
1/4"	35.0	35.0	25.5
3/8"	28.0	35.0	18.5
1/2"	28.0	35.0	24.0
3/4"	17.5	21.0	15.0
1"	14.0	21.0	10.5
1 1/2"	10.5	10.5	10.5
2 1/2"	10.5		8.5

Body size inch	ANSI/ISO Pressure rating MPa		
	Steel	Stainless steel	Brass
1/8"	35.0	14.0	7.0
1/4"	35.0	14.0	7.0
3/8"	28.0	10.5	7.0
1/2"	28.0	10.5	7.0
3/4"	17.5	10.5	7.0
1"	14.0	7.0	7.0
1 1/2"	7.0	7.0	5.5
2 1/2"	7.0		5.5

* Values shown for stainless steel are valid for both AISI 303 and AISI 316.

Temperature rating :

	Part number suffix	O-ring compound	Temperature range
Standard	No suffix	NBR (Nitrile)	-40°C +110°C
	Y	FKM (Viton™)	-20°C +200°C
Option	W	EPDM (Ethylene Propylene)	-40°C +150°C
	Z	CR (Neoprene)	-40°C +100°C

Vacuum data :

696 mm Hg both connected and disconnected

Pressure drop

Tests with oil viscosity 43 cSt at 38°C.

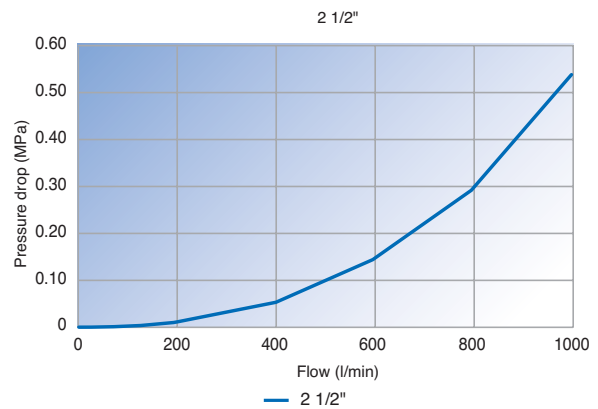
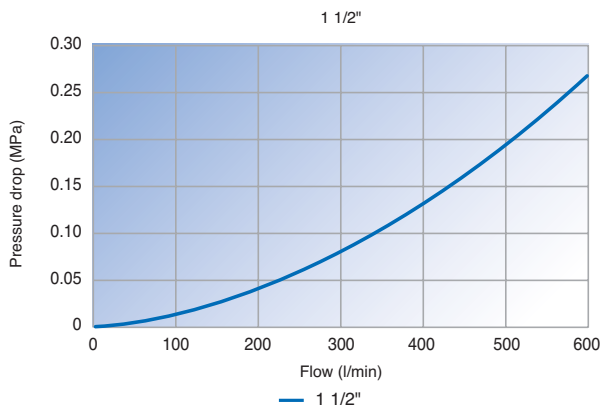
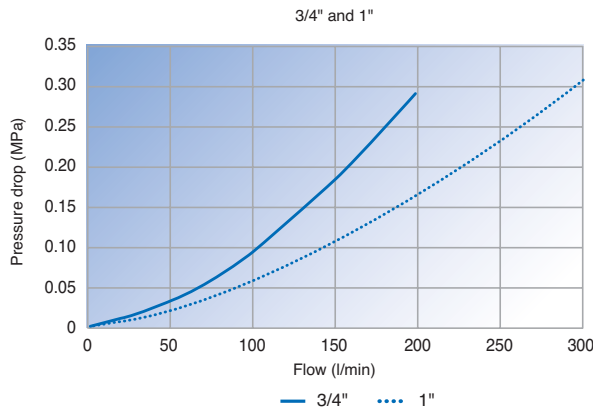
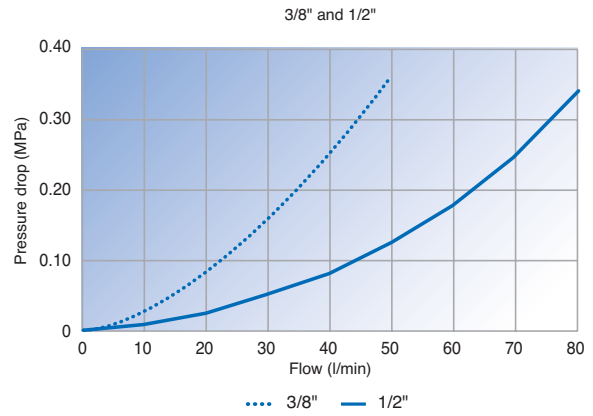
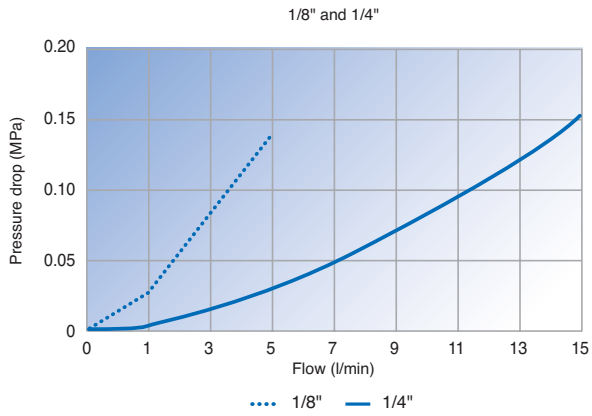

Dimensions and part numbers

STEEL COUPLERS

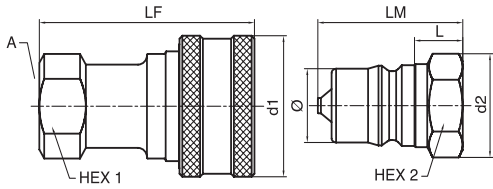

Body size inch	Thread A inch	d1 mm	Hex 1 inch	LF mm	d2 mm	Hex 2 inch	L mm	LM mm	Ø mm	Part number female body	Weight gr./piece	Part number male tip	Weight gr./piece
Female BSPP thread													
1/8"	1/8	24.4	11/16"	48.3	16.4	9/16"	10.5	32.0	10.8	H1-62-BSPP	81	H1-63-BSPP	18
1/4"	1/4	29.0	13/16"	61.2	21.9	3/4"	16.6	42.9	14.2	H2-62-BSPP	130	H2-63-BSPP	38
3/8"	3/8	35.6	1"	69.9	25.7	7/8"	19.7	49.3	19.1	H3-62-BSPP	241	H3-63-BSPP	68
1/2"	1/2	45.0	1 1/8"	77.5	32.9	1 1/8"	21.1	54.1	23.5	H4-62-BSPP	360	H4-63-BSPP	122
3/4"	3/4	54.4	1 5/16"	93.2	40.3	1 3/8"	21.9	64.5	31.4	H6-62-BSPP	602	H6-63-BSPP	217
1"	1	64.0	1 5/8"	106.2	47.2	1 5/8"	25.2	73.8	37.7	H8-62-BSPP	906	H8-63-BSPP	341

Female NPTF thread													
1/8"	1/8 - 27	24.4	11/16"	48.3	16.5	9/16"	11.2	32.0	10.8	H1-62	81	H1-63	18
1/4"	1/4 - 18	29.0	13/16"	57.4	21.9	3/4"	14.0	39.1	14.2	H2-62	138	H2-63	36
3/8"	3/8 - 18	35.4	7/8"	63.2	25.6	7/8"	13.1	42.7	19.1	H3-62	184	H3-63	56
1/2"	1/2 - 14	45.0	1 1/8"	72.9	33.0	1 1/8"	17.5	49.3	23.5	H4-62	341	H4-63	109
3/4"	3/4 - 14	54.4	1 5/16"	90.4	40.3	1 3/8"	20.1	61.7	31.4	H6-62	592	H6-63	210
1"	1 - 11 1/2	64.0	1 5/8"	106.2	47.8	1 5/8"	33.4	73.9	37.7	H8-62	914	H8-63	351

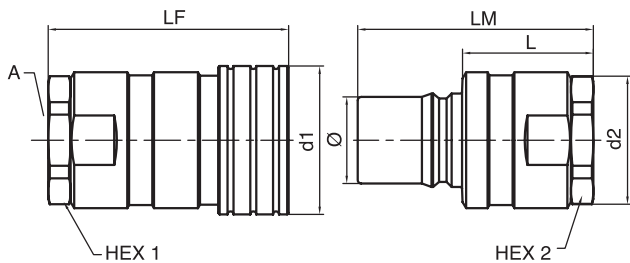

Body size inch	Thread A inch	d1 mm	Hex 1 inch	LF mm	d2 mm	Hex 2 inch	L mm	LM mm	Ø mm	Part number female body	Part number male tip
Female BSPP thread											
1 1/2"	1 1/4	76.2	2 3/8"	123.4	69.9	2 3/8"	67.5	120.9	44.5	H12-62L-BSPP	H12-63L-BSPP
	1 1/2	76.2	2 3/8"	127.3	69.9	2 3/8"	71.1	124.7	44.5	H12-62N-BSPP	H12-63N-BSPP
2 1/2"	2	104.1	3 3/4"	145.0	104.1	3 3/4"	69.4	142.7	63.2	H2016-62-BSPP	H2016-63-BSPP
Female NPTF thread											
1 1/2"	1 1/4 - 11 1/2	76.2	2 3/8"	123.4	69.9	2 3/8"	67.3	120.9	44.5	H12-62L	H12-63L
	1 1/2 - 11 1/2	76.2	2 3/8"	123.4	69.9	2 3/8"	67.3	120.9	44.5	H12-62N	H12-63N
2 1/2"	2 - 11 1/2	104.1	3 3/4"	141.5	104.1	3 3/4"	65.9	139.2	63.2	H2016-62	H2016-63
	2 1/2 - 8	104.1	3 3/4"	153.4	104.1	3 3/4"	83.4	151.1	63.2	H2020-62	H2020-63

Note : Quick couplings with UNF thread are also available upon request. Please consult us for these configurations.

AISI 303 STAINLESS STEEL COUPLERS

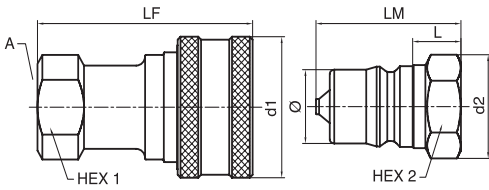

Body size inch	Thread A inch	d1 mm	Hex 1	LF mm	d2 mm	Hex 2	L mm	LM mm	Ø mm	Part number female body	Weight gr./piece	Part number male tip	Weight gr./piece
Female BSPP thread													
1/8"	1/8	24.4	11/16"	48.3	16.4	9/16"	10.5	32.0	10.8	SH1-62-BSPP	81	SH1-63-BSPP	18
1/4"	1/4	29.0	19 mm	61.2	21.9	19 mm	16.6	39.1	14.2	SH2-62-BSPP	129	SH2-63-BSPP	36
3/8"	3/8	35.6	1"	69.9	25.7	7/8"	19.7	49.3	19.1	SH3-62-BSPP	245	SH3-63-BSPP	69
1/2"	1/2	45.0	1 1/8"	77.5	32.9	1 1/8"	21.1	54.1	23.5	SH4-62-BSPP	360	SH4-63-BSPP	122
3/4"	3/4	54.4	1 5/16"	93.2	40.3	1 3/8"	21.9	64.5	31.4	SH6-62-BSPP	603	SH6-63-BSPP	217
1"	1	64.0	1 5/8"	106.2	47.2	1 5/8"	25.2	73.8	37.7	SH8-62-BSPP	908	SH8-63-BSPP	345

Female NPTF thread													
1/8"	1/8 - 27	24.4	11/16"	48.3	16.5	9/16"	11.2	32.0	10.8	SH1-62	81	SH1-63	18
1/4"	1/4 - 18	29.0	13/16"	57.4	21.9	3/4"	14.0	39.1	14.2	SH2-62	128	SH2-63	37
3/8"	3/8 - 18	35.4	7/8"	63.2	25.6	7/8"	13.1	42.7	19.1	SH3-62	186	SH3-63	58
1/2"	1/2 - 14	45.0	1 1/8"	72.9	33.0	1 1/8"	17.5	49.3	23.5	SH4-62	341	SH4-63	109
3/4"	3/4 - 14	54.4	1 5/16"	90.4	40.3	1 3/8"	20.1	61.7	31.4	SH6-62	595	SH6-63	212
1"	1 - 11 1/2	64.0	1 5/8"	106.2	47.8	1 5/8"	33.4	73.9	37.7	SH8-62	924	SH8-63	356

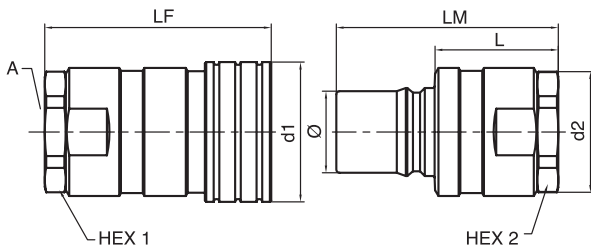

Body size inch	Thread A inch	d1 mm	Hex 1 inch	LF mm	d2 mm	Hex 2 inch	L mm	LM mm	Ø mm	Part number female body	Part number male tip
Female BSPP thread											
1 1/2"	1 1/2	76.2	2 1/2"	127.3	69.9	2 1/2"	67.5	124.7	44.5	SH12-62N-BSPP	SH12-63N-BSPP
Female NPTF thread											
1 1/2"	1 1/2 - 11 1/2	76.2	2 3/8"	123.4	69.9	2 3/8"	67.3	120.9	44.5	SH12-62N	SH12-63N

Note : Quick couplings with UNF thread are also available upon request. Please contact us for these configurations.

AISI 316 STAINLESS STEEL COUPLERS

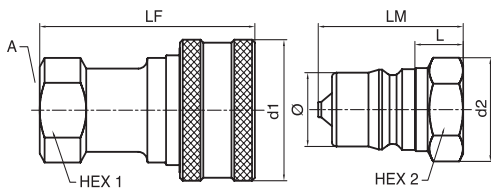

Body size inch	Thread A inch	d1 mm	Hex 1	LF mm	d2 mm	Hex 2	L mm	LM mm	Ø mm	Part number female body	Weight gr./piece	Part number male tip	Weight gr./piece
Female BSPP thread													
1/8"	1/8	24.0	14 mm	48.3	19.6	17 mm	10.5	32.0	10.8	SSH1-62Y-BSPP*	74	SSH1-63Y-BSPP*	22
1/4"	1/4	29.0	13/16"	61.2	21.9	3/4"	16.6	42.9	14.2	SSH2-62Y-BSPP*	46	SSH2-63Y-BSPP*	42
3/8"	3/8	35.6	1"	69.9	25.7	7/8"	19.7	49.3	19.1	SSH3-62Y-BSPP*	187	SSH3-63Y-BSPP*	60
1/2"	1/2	45.0	1 1/8"	77.5	32.9	1 1/8"	21.1	54.1	23.5	SSH4-62Y-BSPP*	367	SSH4-63Y-BSPP*	123
3/4"	3/4	54.4	1 5/16"	93.2	40.3	1 3/8"	21.9	64.5	31.4	SSH6-62Y-BSPP*	610	SSH6-63Y-BSPP*	218
1"	1	64.0	41 mm	106.2	47.2	41 mm	25.2	73.8	37.7	SSH8-62Y-BSPP*	899	SSH8-63Y-BSPP*	340
Filetage femelle NPTF													
1/8"	1/8 - 27	24.4	11/16"	48.3	16.5	9/16"	11.2	32.0	10.8	SSH1-62Y*	74	SSH1-63Y*	18
1/4"	1/4 - 18	29.0	13/16"	57.4	21.9	3/4"	14.0	39.1	14.2	SSH2-62Y*	138	SSH2-63Y*	37
3/8"	3/8 - 18	35.4	7/8"	63.2	25.6	7/8"	13.1	42.7	19.1	SSH3-62Y*	180	SSH3-63Y*	55
1/2"	1/2 - 14	45.0	1 1/8"	72.9	33.0	1 1/8"	17.5	49.3	23.5	SSH4-62Y*	346	SSH4-63Y*	109
3/4"	3/4 - 14	54.4	1 5/16"	90.4	40.3	1 3/8"	20.1	61.7	31.4	SSH6-62Y*	592	SSH6-63Y*	210
1"	1 - 11 1/2	64.0	1 5/8"	106.2	47.8	1 5/8"	33.4	73.9	37.7	SSH8-62Y*	901	SSH8-63Y*	345

*Suffix Y designates FKM (Viton™) seal.

Note : Quick couplings with UNF thread are also available upon request. Please contact us for these configurations.

BRASS COUPLERS

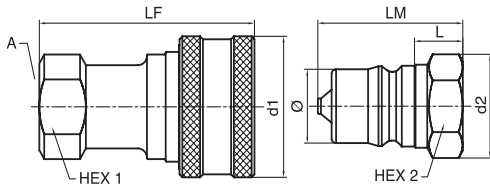

Body size inch	Thread A inch	d1 mm	Hex 1 inch	LF mm	d2 mm	Hex 2 inch	L mm	LM mm	Ø mm	Part number female body	Weight gr./piece	Part number male tip	Weight gr./piece
Female BSPP thread													
1/8"	1/8	24.4	11/16"	48.3	16.4	9/16"	10.5	32.0	10.8	BH1-60-BSPP	87	BH1-61-BSPP	19
1/4"	1/4	29.0	13/16"	61.2	21.9	3/4"	16.6	42.9	14.2	BH2-60-BSPP	158	BH2-61-BSPP	45
3/8"	3/8	35.6	1"	69.9	25.7	7/8"	19.7	49.3	19.1	BH3-60-BSPP	260	BH3-61-BSPP	74
1/2"	1/2	45.0	1 1/8"	77.5	32.9	1 1/8"	21.1	54.1	23.5	BH4-60-BSPP	383	BH4-61-BSPP	131
3/4"	3/4	54.4	1 5/16"	93.2	40.3	1 3/8"	21.9	64.5	31.4	BH6-60-BSPP	642	BH6-61-BSPP	235
1"	1	64.0	1 5/8"	106.2	47.2	1 5/8"	25.2	73.8	37.7	BH8-60-BSPP	971	BH8-61-BSPP	368

Female NPTF thread													
1/8"	1/8 - 27	24.4	11/16"	48.3	16.5	9/16"	11.2	32.0	10.8	BH1-60	80	BH1-61	19
1/4"	1/4 - 18	29.0	13/16"	57.4	21.9	3/4"	14.0	39.1	14.2	BH2-60	145	BH2-61	46
3/8"	3/8 - 18	35.4	7/8"	63.2	25.6	7/8"	13.1	42.7	19.1	BH3-60	195	BH3-61	62
1/2"	1/2 - 14	45.0	1 1/8"	72.9	33.0	1 1/8"	17.5	49.3	23.5	BH4-60	365	BH4-61	118
3/4"	3/4 - 14	54.4	1 5/16"	90.4	40.3	1 3/8"	20.1	61.7	31.4	BH6-60	630	BH6-61	229
1"	1 - 11 1/2	64.0	1 5/8"	106.2	47.8	1 5/8"	33.4	73.9	37.7	BH8-60	980	BH8-61	378

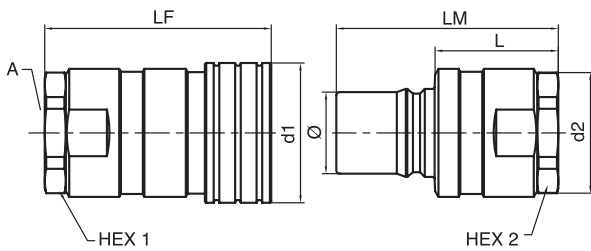

Body size inch	Thread A inch	d1 mm	Hex 1 inch	LF mm	d2 mm	Hex 2 inch	L mm	LM mm	Ø mm	Part number female body	Part number male tip
Female BSPP thread											
1 1/2"	1 1/4	76.2	2 3/8"	123.4	74.7	2 3/8"	67.5	120.9	44.5	BH12-60L-BSPP	BH12-61L-BSPP
	1 1/2	76.2	2 3/8"	127.3	74.7	2 3/8"	67.5	124.7	44.5	BH12-60N-BSPP	BH12-61N-BSPP
2 1/2"	2	101.1	3 3/4"	145.0	104.1	3 3/4"	77.3	142.7	63.2	BH2016-60-BSPP	BH2016-61-BSPP
Female NPTF thread											
1 1/2"	1 1/4 - 11 1/2	76.2	2 3/8"	123.4	69.9	2 3/8"	67.3	120.9	44.5	BH12-60L	BH12-61L
	1 1/2 - 11 1/2	76.2	2 3/8"	123.4	69.9	2 3/8"	67.3	120.9	44.5	BH12-60N	BH12-61N
2 1/2"	2 - 11 1/2	101.1	3 3/4"	141.5	104.1	3 3/4"	73.7	139.2	63.2	BH2016-60	BH2016-61

Note : Quick couplings with UNF thread LM are also available upon request. Please contact us for these configurations.

Options

Heavy duty nipples:

Parker 60 series heavy duty nipples are recommended for extended life in applications where high cycle rates and pressure surges are encountered. Machined from high tensile steel and specially hardened. To specify a heavy duty nipple, add the prefix **HD** to the steel series part number, thus: **HDH2-63** and contact us.

Sleeve-lock:

60 series couplers (as well as sleeve type couplers) are available with safety locking sleeves. Please add the suffix **SL** to the part number, e.g. **H3-62SL** and contact us.

Seals:

Other seal materials (Ethylene Propylene - EPDM, Neoprene - CR, Perfluoroelastomer - Kalrez™) are available upon request. Please contact us for further information.

Dust caps and plugs

Body size inch	Plug part number for female body		Cap part number for male tip	
	Aluminium	Rubber	Aluminium	Rubber
1/8"	H1-65	H1-65M	H1-66	H1-66M
1/4"	H2-65	H2-65M	H2-66	H2-66M
3/8"	H3-65	H3-65M	H3-66	H3-66M
1/2"	H4-65	H4-65M	H4-66	H4-66M
3/4"	H6-65	H6-65M	H6-66	H6-66M
1"	H8-65	H8-65M	H8-66	H8-66M
1 1/2"	H12-65	-	H12-66	-

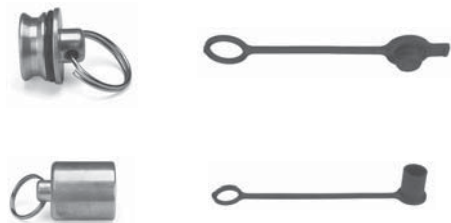











Stainless steel AISI 316 dust plugs and caps are available upon request. Please consult us.

Replacement seals

Body size inch	Body seal		Back-up ring* PTFE
	NBR (Nitrile)	FKM (Viton™)	
1/8"	JT020013N0674	JT020013V0747	H67A-28
1/4"	JT020015N0674	JT020015V0747	H67C-28
3/8"	JT020116N0674	JT020116V0747	4118007
1/2"	JT020213N0674	JT020213V0747	4128002
3/4"	JT020218N0674	JT020218V0747	4148001
1"	JT020222N0674	JT020222V0747	4158001
1 1/2"	JT020224N0674 (2 body seals necessary)		-
2 1/2"	JT020333N0674		-



*Brass 60 series couplers use two O-rings but do not use a back-up ring.

			 max							
Inter-changeable with similar models	Steel	from 1/4" to 1"	30 MPa	-20°C + 100°C	NBR (nitrile)	Push-to-Connect	Flush-faced poppet	No	Ball locking mechanism with security	BSPP

Main characteristics

- Dimensions meet the requirements of ISO 16028
- Minimal fluid loss during disconnection
- Minimal inclusion of air or external contamination during connection
- Safety system protecting against accidental disconnection
- Minimal pressure drop

Applications

- Industrial applications
- Agriculture
- Road service vehicles, snow ploughs
- Construction: excavators, rock hammers...



Technical features

Chrome 6 free plated steel

Seal : NBR (Nitrile) and back-up ring in PTFE to withstand flow surges at high flow rates

Ball locking mechanism

Valving: **flush-faced poppet** for reduced spillage during disconnection. The seal is crimped to prevent seal washout at high flow rates

A **safety sleeve lock** prevents accidental disconnection. Sleeve is rotated to the stop to engage the lock

Push-to-connect system: push on the male tip to connect and pull on the sleeve to disconnect

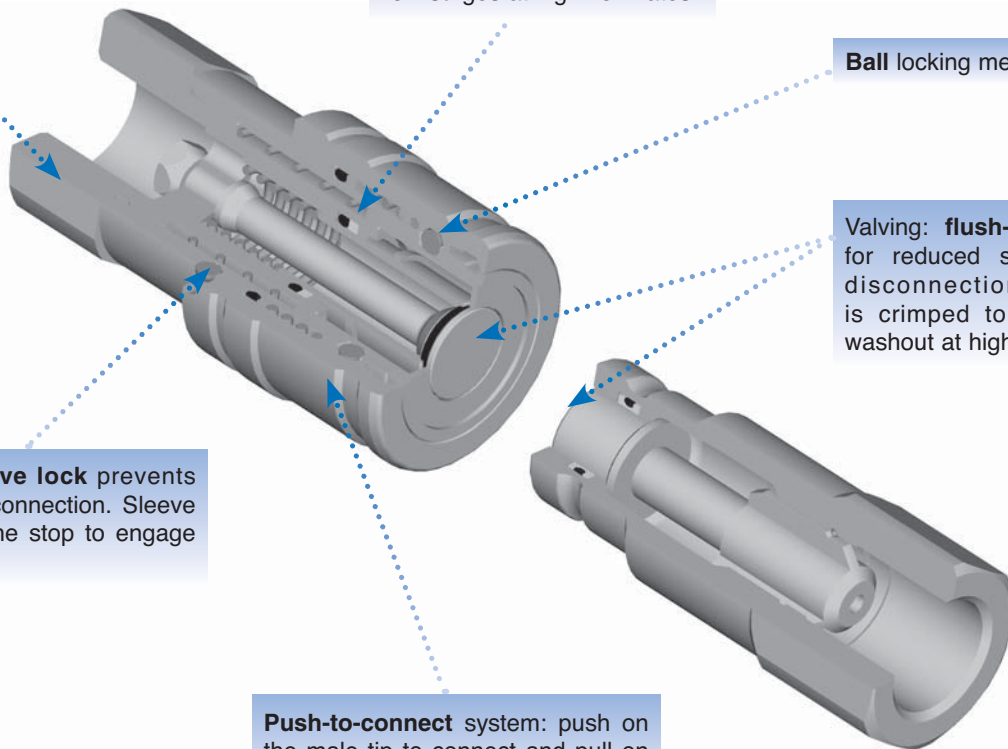

Technical performance data

Body size inch	Temperature range	Max. operating pressure connected* MPa	Min. burst pressure connected* MPa
1/4"	-20°C + 100°C	30	120
3/8"		30	120
1/2"		25	100
5/8"		25	100
3/4"		25	100
1"		25	100

*Warning : the maximum operating pressure and the burst pressure are valid only for the connected position. Do not use the female body disconnected with pressure impulses.

Pressure drop

Tests with oil viscosity 43 cSt at 38° C.

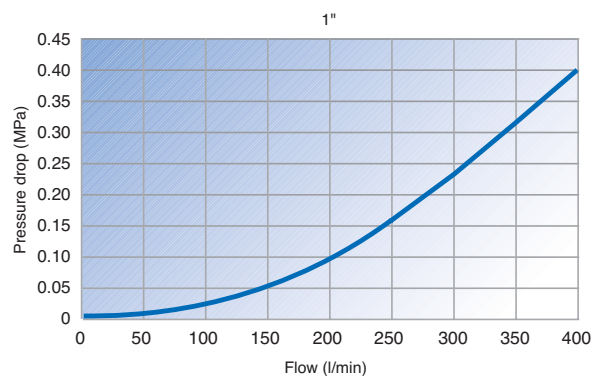
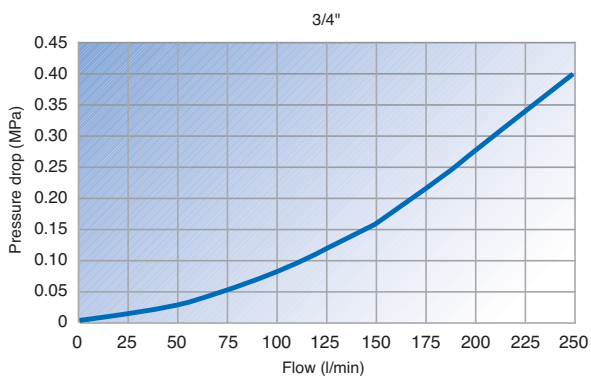
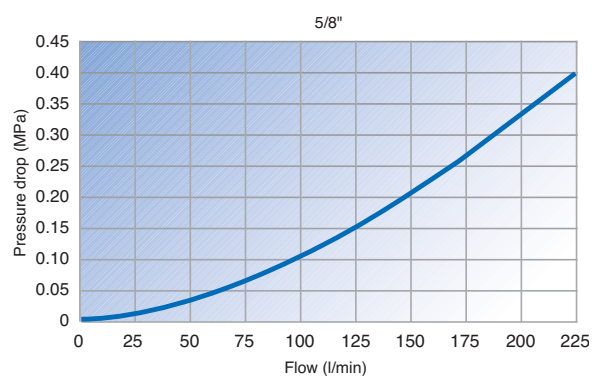
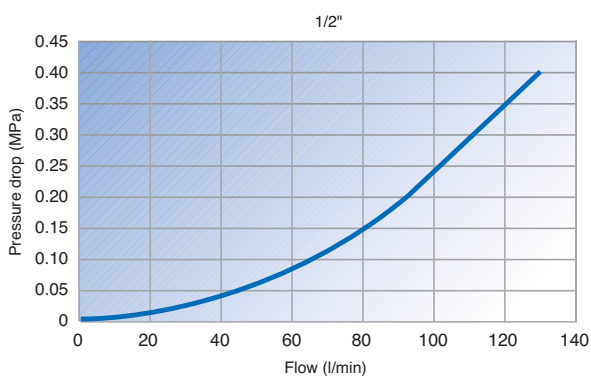
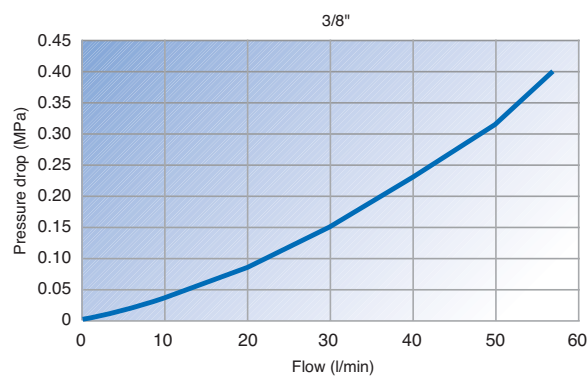
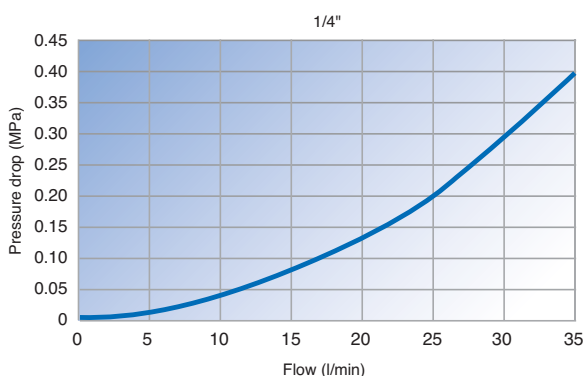

Dimensions and part numbers

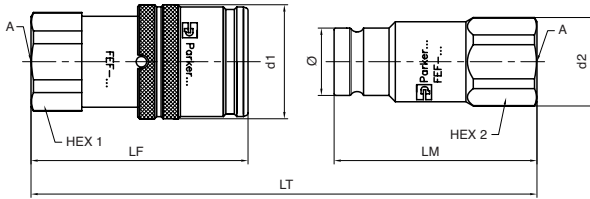

Body size pouce	Thread A pouce	d1 mm	Hex 1 mm	LF mm	d2 mm	Hex 2 mm	LM mm	LT connected mm	Ø mm	Part number female body	Weight gr./pièce	Part number male tip	Weight gr./pièce
Female BSPP thread													
1/4"	1/4	29.5	22	48.1	23.8	22	47.9	85.2	16.1	FEF-251-4FB	147	FEF-252-4FB	86
3/8"	3/8	33.5	27	64.2	26.0	24	60.0	108.7	19.7	FEF-371-6FB	247	FEF-372-6FB	121
	1/2	33.5	27	69.2	29.0	27	62.5	116.2	19.7	FEF-371-8FB	249	FEF-372-8FB	128
1/2"	1/2	39.5	32	73.8	33.8	32	68.0	124.6	24.5	FEF-501-8FB	390	FEF-502-8FB	233
	3/4	39.5	36	80.8	38.5	36	70.5	134.1	24.5	FEF-501-12FB	428	FEF-502-12FB	227
5/8"	3/4	43.5	36	78.5	38.5	36	70.5	131.5	27.0	FEF-621-12FB	499	FEF-622-12FB	268
3/4"	1	49.5	45	93.2	47.8	45	82.3	153.7	30.0	FEF-751-16FB	811	FEF-752-16FB	394
1"	1-1/4	56.5	55	106.0	59.8	55	89.8	172.8	36.0	FEF-1001-20FB	1266	FEF-1002-20FB	641

Dust caps and plugs

Plastic

Body size inch	Plug part number for female body	Cap part number for male tip
1/4"	PFE-251-P	CFE-252-P
3/8"	PFE-371-P	CFE-372-P
1/2"	PFE-501-P	CFE-502-P
5/8"	PFE-621-P	CFE-622-P
3/4"	PFE-751-P	CFE-752-P
1"	PFE-1001-P	CFE-1002-P











Automatic dust cap for female body

Plastic

Body size inch	Cap part number for female body
1/2"	DFE-501-P

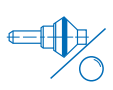
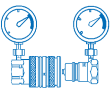

Note : Standard dust caps and plugs are black. Please consult us for other colours.

			 max							
ISO 16028 and HTMA (for size 3/8")	Steel	from 1/4" to 1"	31.5 MPa	-20°C + 100°C	NBR (nitrile)	Push-to-Connect	Flush-faced poppet	No	Ball locking mechanism with security	BSPP, Metric

Main characteristics

- Meets the requirements of **ISO 16028**
- Minimal fluid loss during disconnection
- Minimal inclusion of air or external agents during connection
- Safety system protecting against accidental disconnection
- Modular construction: broad choice of end configurations
- Minimal pressure drop

Applications

- Hydraulic applications: excavators, rock hammers, drilling rigs
- Road service vehicles, snow ploughs...
- Difficult working conditions: pressure impulses



Technical features

Chrome 6 free plated steel

Seal : **NBR** (Nitrile) and back-up ring in PTFE to withstand flow surges at high flow rates

Ball locking mechanism

Valving: **flush-faced poppet** for reduced spillage during disconnection. The seal is crimped to prevent seal washout at high flow rates

A **safety sleeve lock** prevents accidental disconnection. Sleeve is rotated to the stop to engage the lock

Push-to-connect system: push on the male tip to connect and pull on the sleeve to disconnect

Technical performance data

Body size inch	Temperature range	Max. operating pressure MPa	Min. burst pressure MPa
1/4"	-20°C + 100°C	31.5	126
3/8"		25.0	100
1/2"		25.0	100
5/8"		25.0	100
3/4"		25.0	100
1"		20.0	80

Pressure drop

Tests with oil viscosity 43 cSt at 38° C.

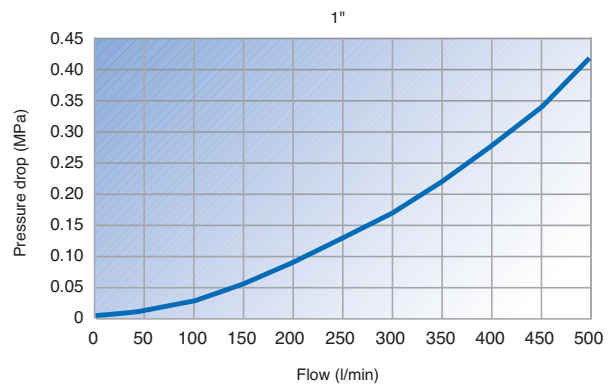
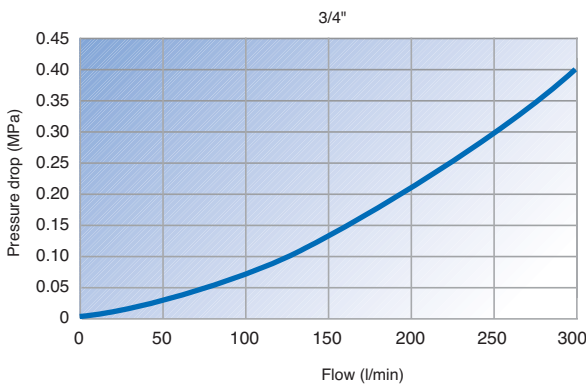
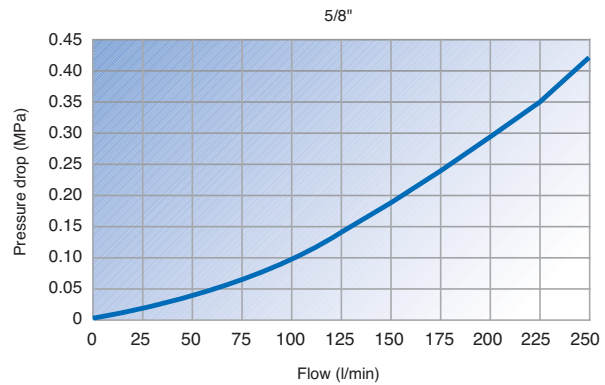
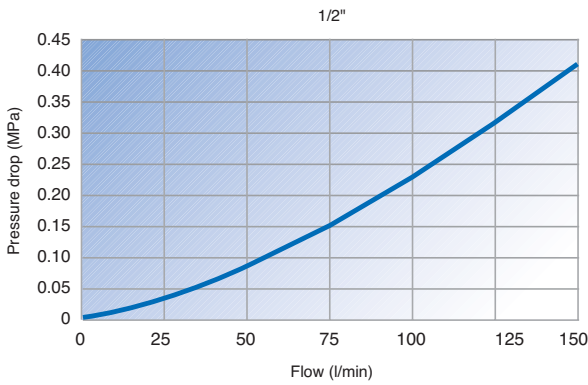
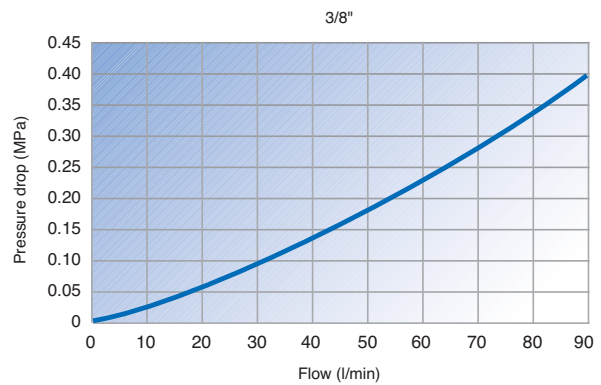
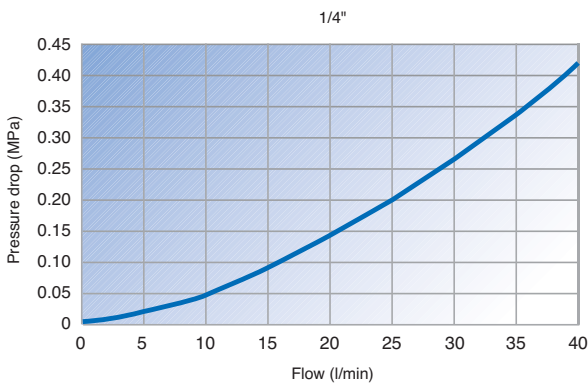

Dimensions and part numbers

Female BSPP thread – DIN 3852

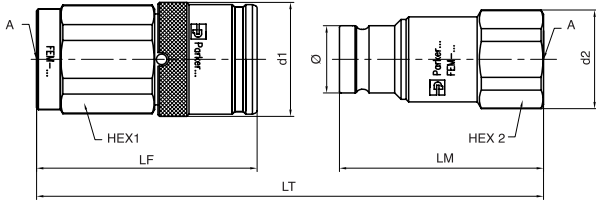

Body size inch	Thread A inch	d1 mm	Hex 1 mm	LF mm	d2 mm	Hex 2 mm	LM mm	LT connected mm	Ø mm	Part number female body	Weight gr./piece	Part number male tip	Weight gr./piece
Female BSPP thread													
1/4"	1/4	29.5	27	53.1	23.8	22	47.9	90.2	16.1	FEM-251-4FB	193	FEM-252-4FB	86
3/8"	3/8	33.5	30	64.8	29.0	27	60.0	108.8	19.7	FEM-371-6FB	286	FEM-372-6FB	146
	1/2	33.5	30	69.8	29.0	27	62.5	116.3	19.7	FEM-371-8FB	286	FEM-372-8FB	146
1/2"	1/2	39.5	36	76.8	35.0	32	68.0	127.6	24.5	FEM-501-8FB	467	FEM-502-8FB	235
	3/4	39.5	36	83.8	40.0	36	70.5	137.1	24.5	FEM-501-12FB	477	FEM-502-12FB	273
5/8"	3/4	43.5	41	84.0	38.5	36	73.0	139.5	27.0	FEM-621-12FB	640	FEM-622-12FB	299
3/4"	1	49.5	46	98.8	49.8	46	83.7	160.7	30.0	FEM-751-16FB	983	FEM-752-16FB	475
1"	1-1/4	56.5	55	105.8	59.8	55	90.0	172.8	36.0	FEM-1001-20FB	1365	FEM-1002-20FB	706

24° cone – DIN 2353

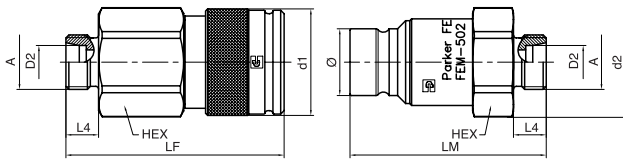

Body size inch	Series	Tube O/D D2	DN mm	Thread A mm	d1 mm	Hex mm	LF mm	d2 mm	LM mm	LT connected mm	L4 mm	Ø mm	Part number female body	Weight gr./piece	Part number male tip	Weight gr./piece
Male metric thread																
3/8"	L*	10	8	M16X1.5	33.5	30	69.6	32	65.5	119.1	11	19.7	FEM-371-16MCL	270	FEM-372-16MCL	155
	L*	12	10	M18X1.5	33.5	30	67.6	32	65.5	117.1	11	19.7	FEM-371-18MCL	262	FEM-372-18MCL	155
	L*	15	12	M22X1.5	33.5	30	68.6	32	66.5	119.1	12	19.7	FEM-371-22MCL	268	FEM-372-22MCL	161
1/2"	L*	12	10	M18X1.5	39.5	36	79.1	40	71.0	132.9	11	24.5	FEM-501-18MCL	433	FEM-502-18MCL	259
	L*	15	12	M22X1.5	39.5	36	80.1	40	72.0	134.9	12	24.5	FEM-501-22MCL	441	FEM-502-22MCL	265

*Light series

24° cone – DIN 2353 - Bulkhead

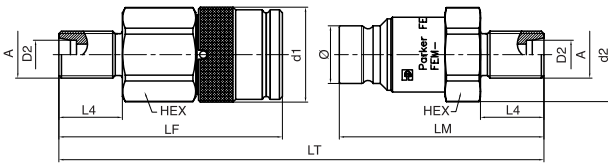

Body size inch	Series	Tube O/D D2	DN mm	Thread mm	A mm	d1 mm	Hex mm	LF mm	d2 mm	LM mm	LT connected mm	L4 mm	Ø mm	Part number female body	Weight gr./piece	Part number male tip	Weight gr./piece
Male metric thread																	
3/8"	L*	10	8	M16X1.5	33.5	30	30	84.6	32.0	80.5	149.1	26	19.7	FEM-371-16BMCL	284	FEM-372-16BMCL	169
	L*	12	10	M18X1.5	33.5	30	30	82.6	32.0	80.5	147.1	26	19.7	FEM-371-18BMCL	279	FEM-372-18BMCL	171
	L*	15	12	M22X1.5	33.5	30	30	83.6	32.0	81.5	149.1	27	19.7	FEM-371-22BMCL	296	FEM-372-22BMCL	188
1/2"	L*	12	10	M18X1.5	39.5	36	36	94.1	40.0	86.0	162.9	26	24.5	FEM-501-18BMCL	451	FEM-502-18BMCL	275
	L*	15	12	M22X1.5	39.5	36	36	95.1	40.0	87.0	164.9	27	24.5	FEM-501-22BMCL	467	FEM-502-22BMCL	292

*Light series

Dust caps and plugs

Plastic

Body size inch	Plug part number for female body	Cap part number for male tip
1/4"	PFE-251-P	CFE-252-P
3/8"	PFE-371-P	CFE-372-P
1/2"	PFE-501-P	CFE-502-P
5/8"	PFE-621-P	CFE-622-P
3/4"	PFE-751-P	CFE-752-P
1"	PFE-1001-P	CFE-1002-P













Automatic dust cap for female body

Plastic

Body size inch	Cap part number for female body
1/2"	DFE-501-P



Note : Standard dust caps and plugs are black. Please consult us for other colours

			 max.							
Inter-changeable with similar models	Brass and Stainless steel	1/4"	6.0 MPa	-20°C +200°C	FKM (Viton™)	Manual	Flat-faced poppet	No	Ball locking mechanism	BSPP, Metric

Main characteristics

- Minimal fluid loss during disconnection
- Minimal inclusion of air or dust during connection
- Maximal flow
- Compact design

Applications

- Thermoplastic injection moulding: for cooling of machinery or temperatures control lines
- Can be used with cold and hot water as well as with heat transfer oils



Technical features

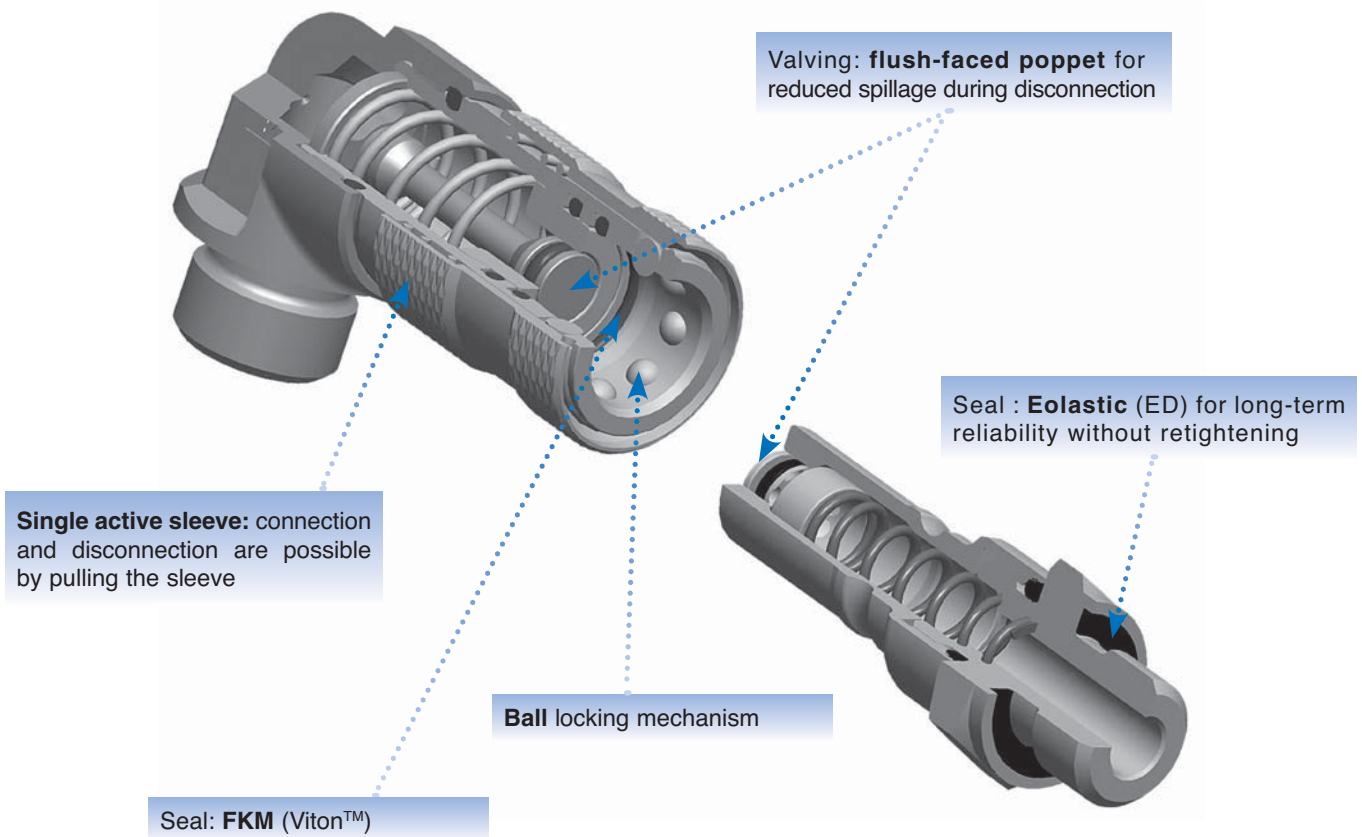

Technical performance data

Body size inch	Temperature range	Max operating pressure MPa	Min burst pressure MPa
1/4"	-20°C +200°C	6.0	20.0

Pressure drop

Test with oil viscosity 43 cSt at 38°C

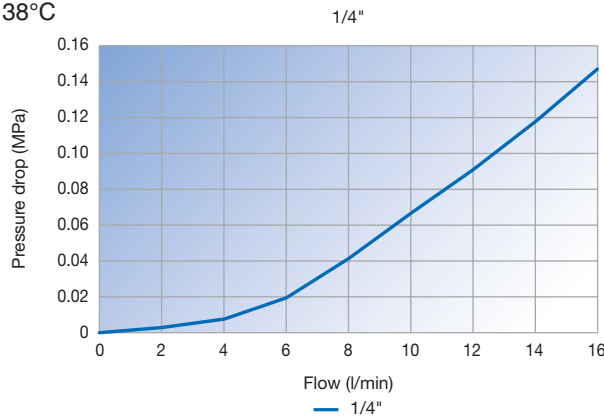

Dimensions and part numbers

Elbowed female version - 24° Cone - DIN 2353

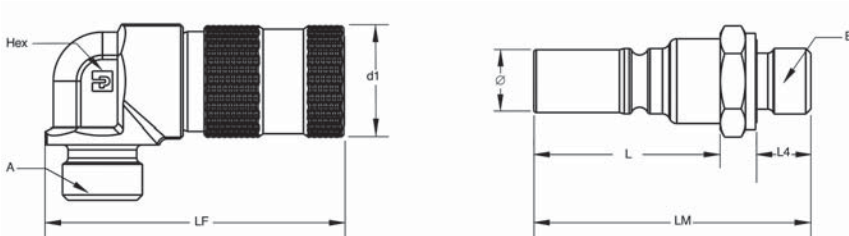





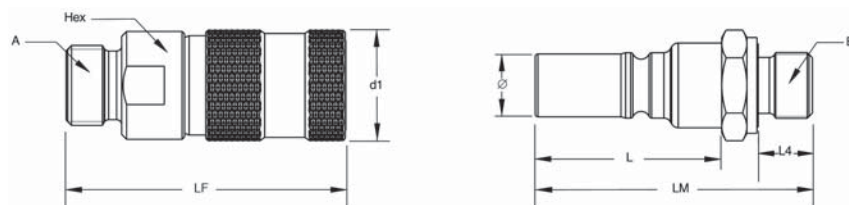



Body size inch	Thread A metric	d1 mm	Hex mm	LF mm	L mm	Thread B BSPP	L4 mm	LM mm	LT mm	connected mm	Ø mm	Part number female body	Weight gr./piece	Part number male tip	Weight gr./piece
1/4	M16x1.5	22.0	17.0	59.2	37.0	1/4	11.0	55.0	89.0	12.5	NSI-251-C16MCL	108	NSI-252-4MBE	48	

Straight female version - 24° Cone - DIN 2353

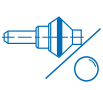
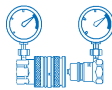

Body size inch	Thread A metric	d1 mm	Hex mm	LF mm	L mm	Thread B BSPP	L4 mm	LM mm	LT mm	connected mm	Ø mm	Part number female body	Weight gr./piece	Part number male tip	Weight gr./piece
1/4	M16x1.5	22.0	20.0	55.5	37.0	1/4	11.0	55.0	85.5	12.5	NSI-251-16MCL	84	NSI-252-4MBE	48	

Other quick couplings for temperature regulation on thermoplastic or aluminium injection moulds will be available soon. Please contact your Parker Sales Engineer.

			 max							
Inter-changeable with similar models	Steel	1/4"	150 MPa	-30°C + 100°C	NBR (nitrile)	Manual	Flat-faced poppet	No	Ball locking mechanism with security	BSPP

Main characteristics

- High pressure coupler up to **150 MPa**
- Interchangeable with similar products
- Reduced spillage
- Maximal security due to a positive locking mechanism

Applications

- Very high pressure hydraulic equipment, clamping devices, torque wrenches, nut runners
- Cable cutters
- Knockout punches



Technical features

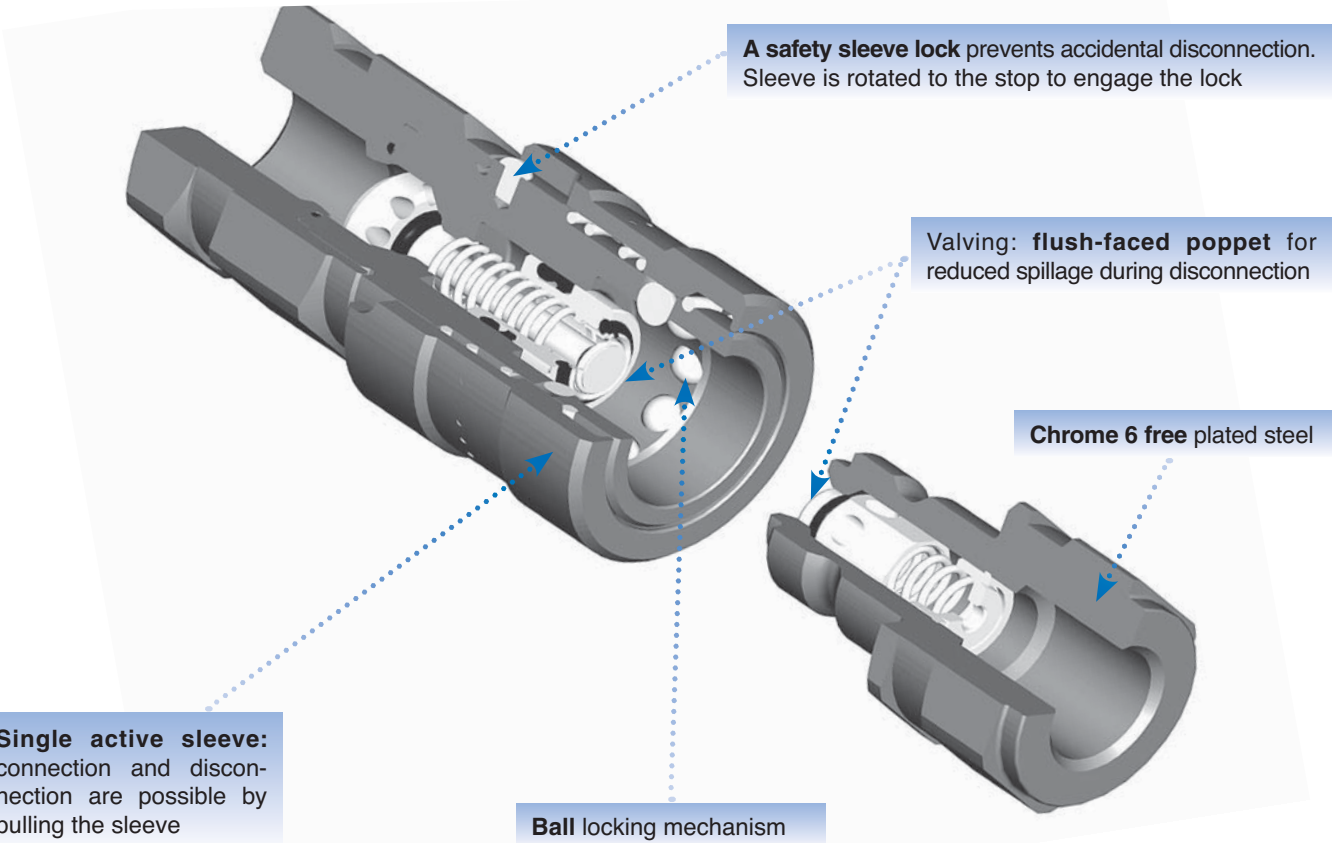

Technical performance data

Body size inch	Temperature range	Max. operating pressure MPa	Min. burst pressure MPa	Spillage max per disconnection* (ml)
1/4"	-30°C +100°C	150	>350	0.025

*Test according to ISO 7241-2

Pressure drop

Test with oil viscosity 32 cSt at 40°C

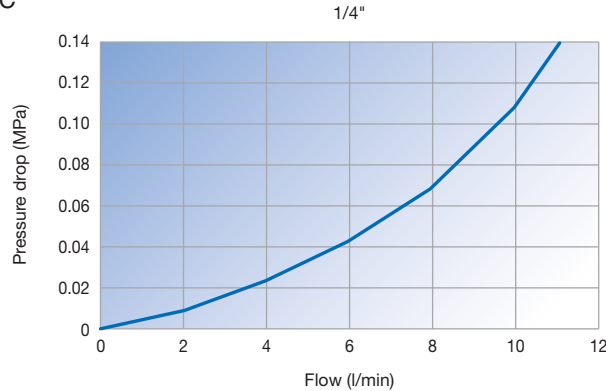

Dimensions and part numbers

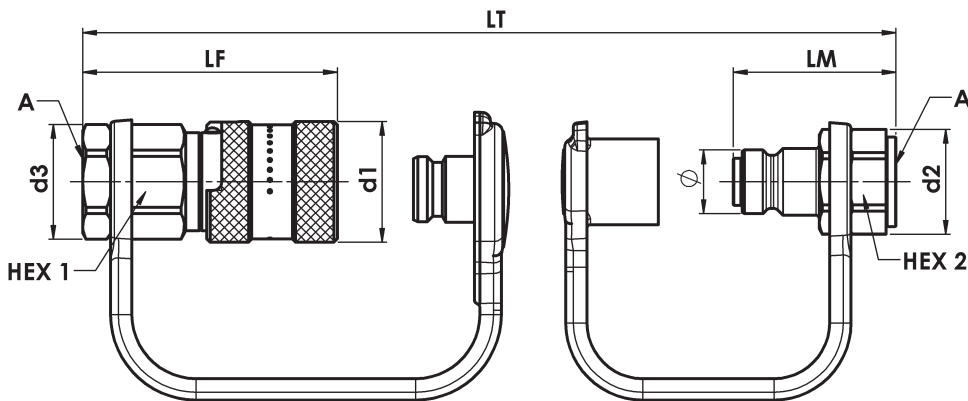

Body size inch	Thread A BSPP	d1 mm	d3 mm	Hex1 mm	LF mm	d2 mm	Hex2 mm	LM mm	LT mm	Ø mm	Part number female body	Weight gr./piece	Part number male tip	Weight gr./piece
1/4"	1/4"	28.2	26.8	24.0	59.5	24.5	22.0	38.0	79.5	14.9	CM-251-4FB-PLP*	192	CM-252-4FB-PLC**	69

* with plug









** with cap

Dust caps and plugs

Body size inch	Plug part number for female body	Cap part number for male tip
1/4"	CPP-253	CPC-254

Standard dust caps and plugs are yellow.

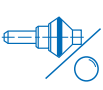
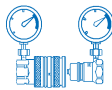

			 max							
Inter-changeable with similar models	Steel	1/4"	100 MPa	-30°C + 100°C	NBR (nitrile)	Manual	Flat-faced poppet	No	Ball locking mechanism with security	BSP

Main characteristics

- High pressure coupling up to 100 MPa
- Interchangeable with similar products
- Reduced spillage
- Maximal security due to a positive locking mechanism

Applications

- Rescue equipment: lifting bags, spreaders, cutters...
- Very high pressure hydraulic equipment: hydraulic jacks, rams, clamping devices, torque wrenches, cable cutters...



Technical features

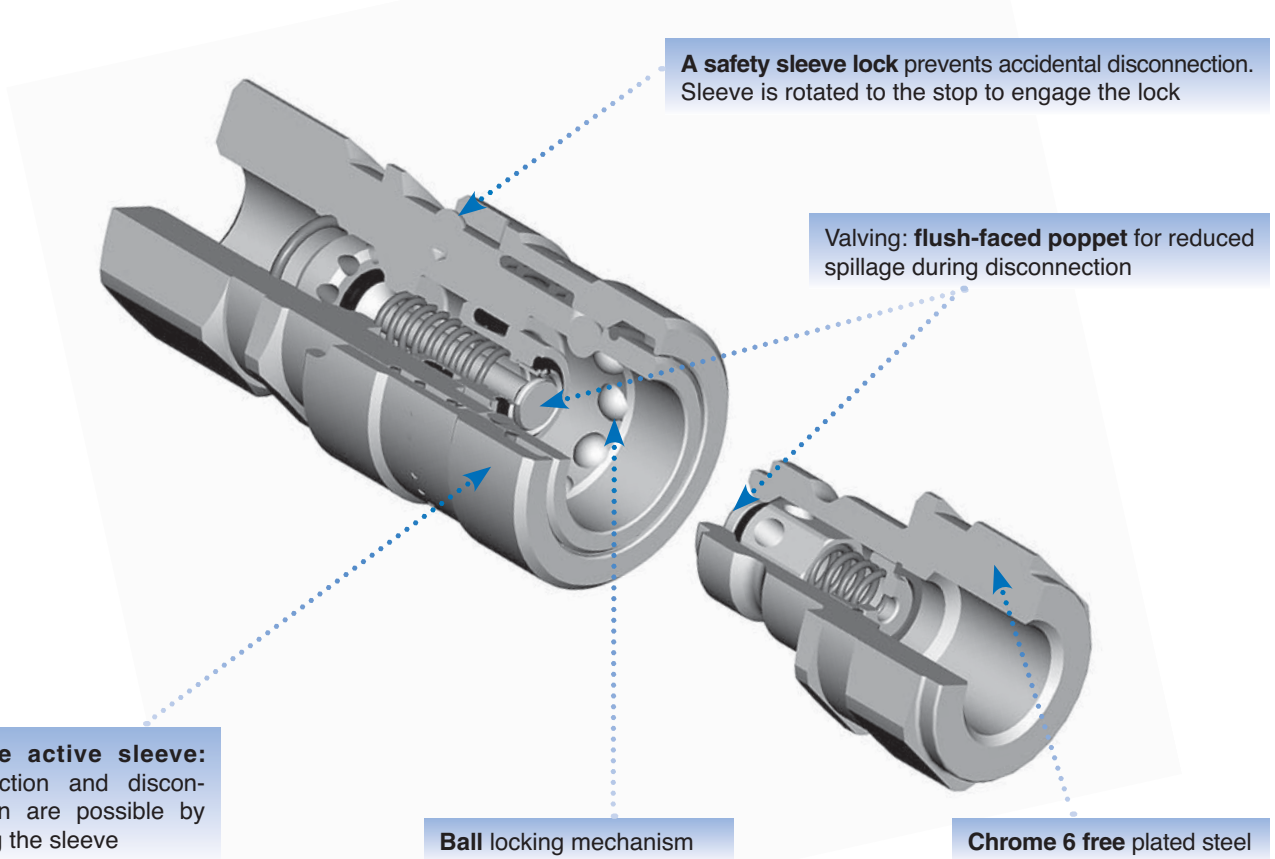

Technical performance data

Body size inch	Temperature range	Max operating pressure MPa	Min burst pressure MPa	Spillage max per disconnection* (ml)
1/4"	-30°C +100°C	100	>300	0.025

*Test according to ISO 7241-2

Pressure drop

Test with oil viscosity 32 cSt at 40°C

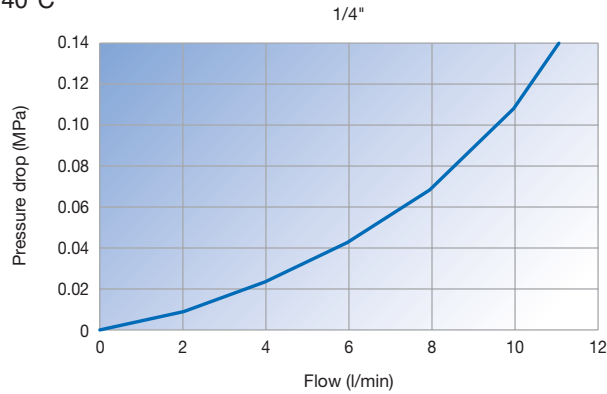

Dimensions and part numbers

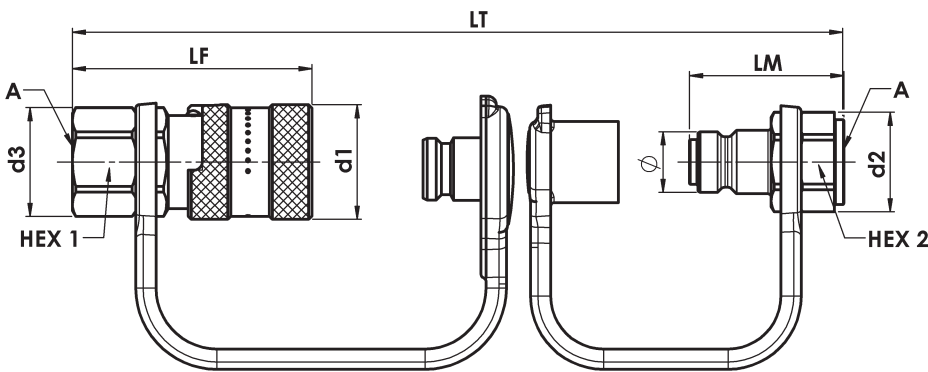

Body size inch	Thread A BSPP	d1 mm	d3 mm	Hex1 mm	LF mm	d2 mm	Hex2 mm	LM mm	LT mm	Ø mm	Part number female body	Weight gr./piece	Part number male tip	Weight gr./piece
1/4"	1/4"	28.2	26.8	24.0	59.0	24.5	22.0	38.0	79.0	14.9	CL-251-4FB-PLP*	192	CL-252-4FB-PLC**	69

* with plug









** with cap

Dust caps and plugs

Body size inch	Plug part number for female body	Cap part number for male tip
1/4"	CPP-253	CPC-254

Standard dust caps and plugs are yellow.

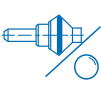
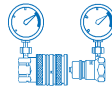

			 max							
Inter-changeable with similar models	Steel	1/4" & 3/8"	70 MPa	-30°C + 110°C (NBR seal) -30°C + 80°C (polyurethane seal)	NBR (1/4") Polyurethane (3/8")	Screw-to-connect	Ball or poppet	No	Screw mechanism	NPTF

Main characteristics

- High pressure coupler up to 70 MPa
- Interchangeable with similar products
- Screw locking mechanism
- Ball or poppet valving

Applications

- Portable hydraulic rams
- Hydraulic jacks, rams and clamping devices
- Clamping hand tools
- Rescue equipment



Technical features

Chrome 6 free plated steel.
Female body and nipple are in high strength steel to prolong life

Seal : - size 1/4" : **NBR (Nitrile)**
- size 3/8" : **Polyurethane**

Screw type locking mechanism

Ball or poppet valving.
(as per chart on page 26)

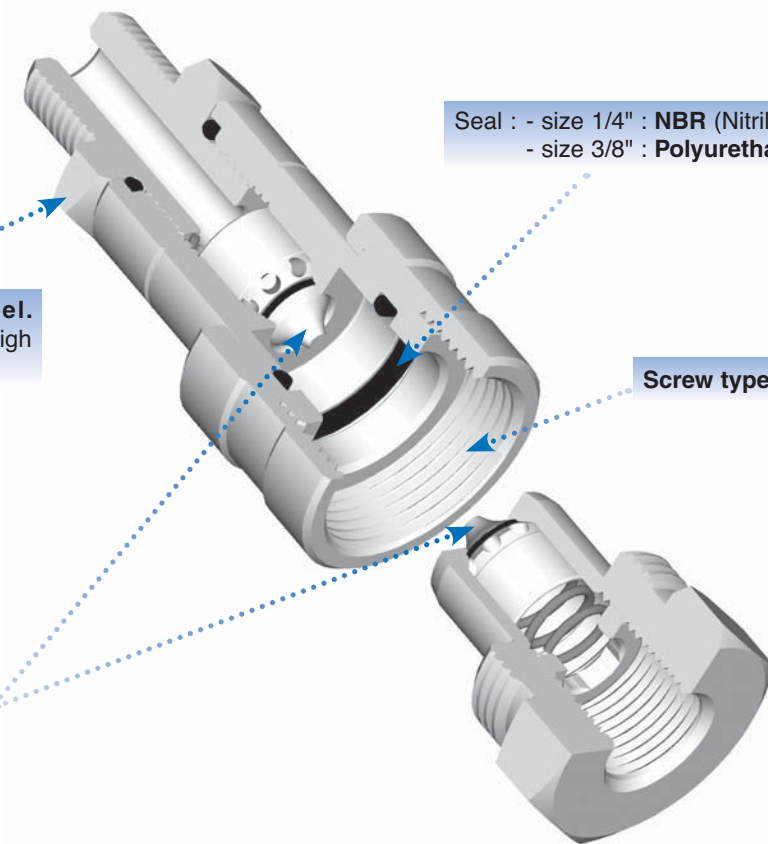

It is possible to connect a male tip with a ball valving and a female body with a poppet valving, and vice-versa. Be careful ! Couplers should be pressurized only when completely connected and should not be coupled or uncoupled when pressurized.

Technical performance data

Body size inch	Temperature range	Max. operating pressure (static) MPa
1/4"	-30°C +110°C	70
3/8"	-30°C +80°C	70

Pressure drop

Test with oil viscosity 43 cSt at 38°C.

Ball valving

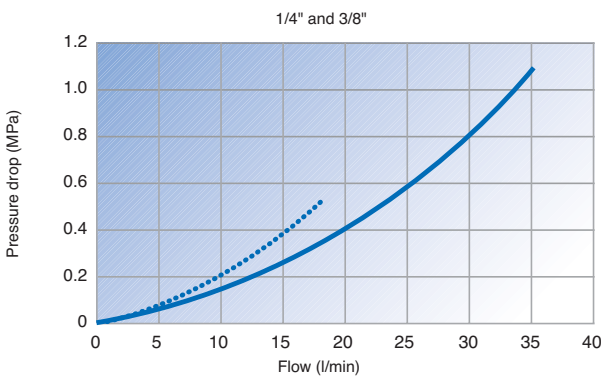

Poppet valving

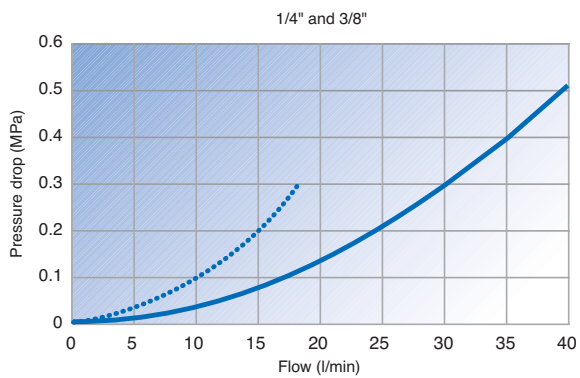

Dimensions and part numbers

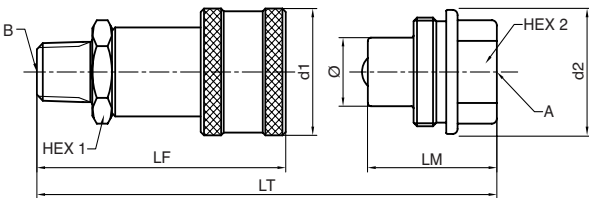

Body size inch	Thread A female	Thread B male	d1 mm	Hex 1	LF mm	d2 mm	Hex 2 mm	LM mm	LT connected mm	Ø mm	Valving Ball Poppet	Part number female body	Weight gr./piece	Part number male tip	Weight gr./piece
1/4"	1/4	1/4	28.6	13/16"	60.5	28.6	19	31.2	72.6	15.8	● ●	3050-2	115	3010-2	70
	1/4	1/4	29.0	22	60.5	31.0	27	32.0	73.7	15.8	● ●	3050-2P	121	3010-2P	85
3/8"	3/8	3/8	35.0	1"	71.9	31.8	15/16"	38.1	84.7	19.0	● ●	3050-3	220	3010-3	115
	3/8	3/8	35.0	1"	73.0	36.8	32	35.1	82.8	19.0	● ●	3050-3P	225	3010-3P	110

NPTF thread

Dust caps and plugs



Body size inch	Dust plug part number for female body	Dust cap part number for male tip
1/4"	3005-2	3009-2
3/8"	3005-3	3009-3

Replacement seals



Body size inch	Material	O-ring seal part number
1/4"	NBR (Nitrile)	JT020114N0552
3/8"	Polyurethane	JT01U28-18.72QE

ISO 7241-1-A	Steel	1/4", 3/8", 1/2", 3/4" & 1"	35 MPa max	-40°C + 110°C	NBR (nitrile)	Manual	Poppet	No	Ball locking mechanism	BSPP

Main characteristics

- Meets the requirements of **ISO 7241-1-Series A**
- Reference couplings for general purpose hydraulic applications

Applications

- Used for a wide range of agricultural applications: tractors, accessories...
- Mobile and construction equipment
- In-plant machinery: hydraulic power units, hand tools



Technical features

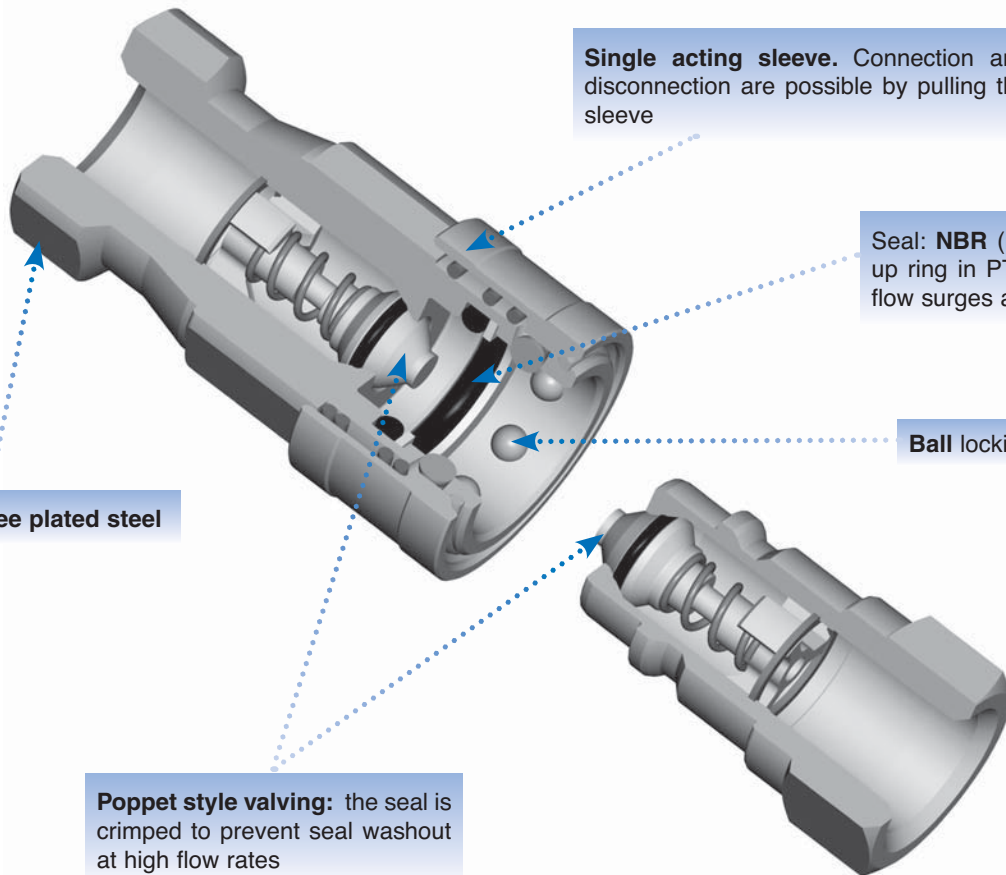

Single acting sleeve. Connection and disconnection are possible by pulling the sleeve

Seal: NBR (nitrile) and back-up ring in PTFE to withstand flow surges at high flow rate

Ball locking mechanism

Chrome 6 free plated steel

Poppet style valving: the seal is crimped to prevent seal washout at high flow rates

Technical performance data

Body size inch	Temperature range	Max. operating pressure MPa
1/4"	-40°C +110°C	35
3/8"		28
1/2"		28
3/4"		28
1"		28

Pressure drop

Tests with oil viscosity 43 cSt at 38°C.

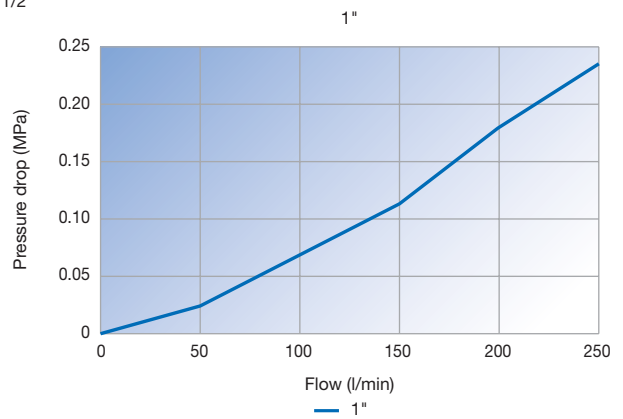
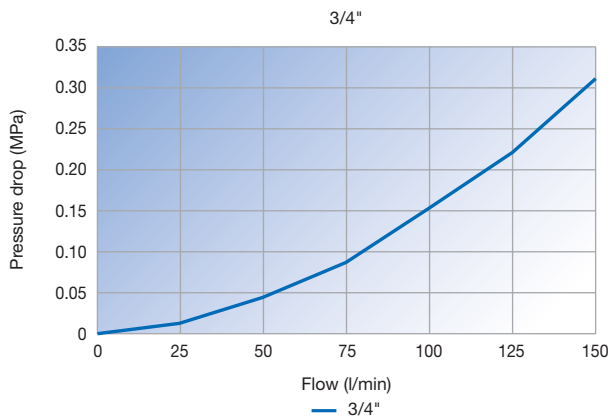
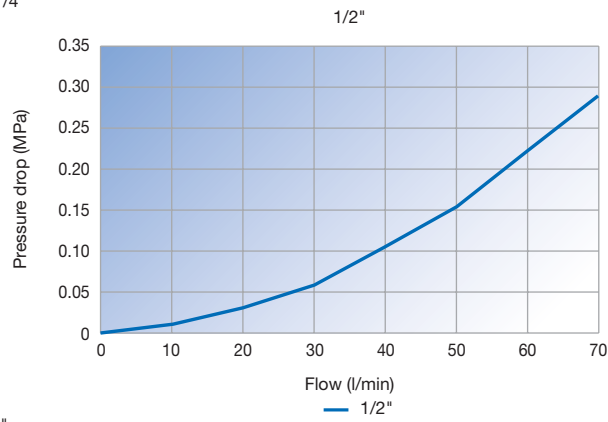
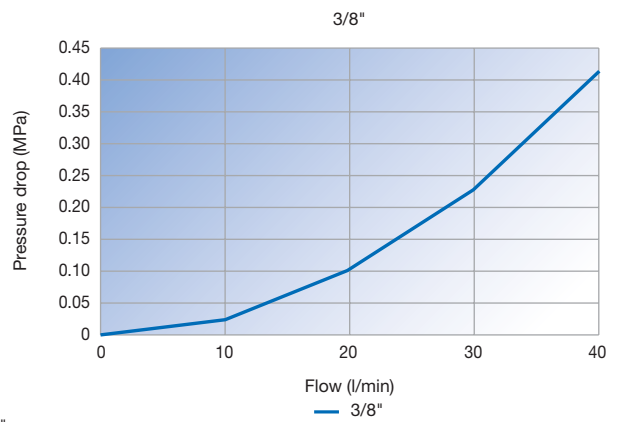
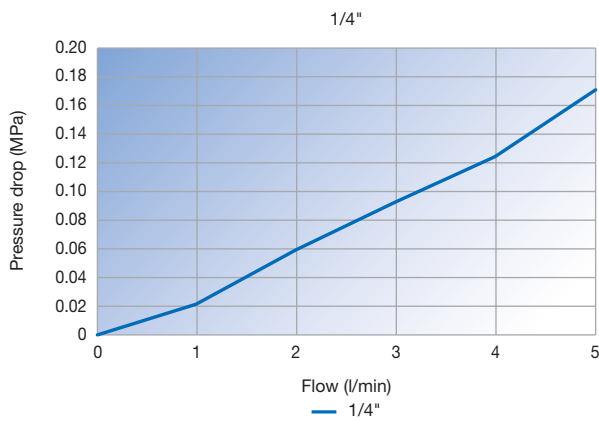

Dimensions and part numbers

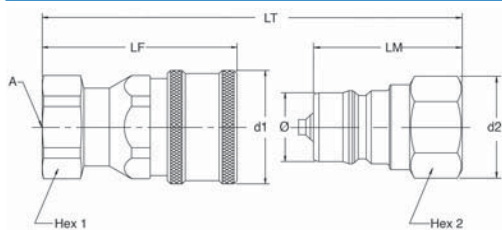

Body size inch	Thread A BSPP	d1 mm	Hex 1 mm	LF mm	d2 mm	Hex 2 mm	LM mm	LT mm	Ø mm	Part number female body	Weight gr./piece	Part number male tip	Weight gr./piece
1/4"	1/4	27.0	22.0	49.0	21.9	19.0	34.5	67.1	11.8	6603-4-4	123	6605-4-4	39
3/8"	3/8	31.8	27.0	56.0	25.3	22.0	38.1	77.0	17.2	6603-6-6	181	6605-6-6	55
1/2"	1/2	38.1	32.0	70.9	31.1	27.0	49.3	99.3	20.5	6603-8-10	309	6605-8-10	97
3/4"	3/4	47.6	41.0	85.3	40.3	35.0	57.9	116.5	29.0	6603-12-12	624	6605-12-12	217
1"	1	54.0	48.0	104.1	47.2	41.0	70.5	139.6	34.3	6603-16-16	842	6605-16-16	331

Dust caps and plugs

Body size inch	Dust plug part number for female body	Dust cap part number for male tip
1/4"	6659-4PL	6657-4PL
3/8"	6659-6PL	6657-6PL
1/2"	6659-8PL	6657-8PL
3/4"	6659-12PL	6657-12PL
1"	6659-16PL	6657-16PL

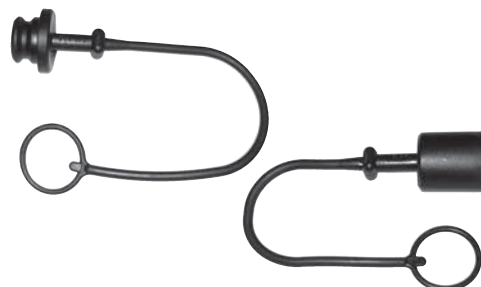

Note : Standard dust caps and plugs are red. Please consult us for other colours.

Replacement seals

Body size inch	O-ring NBR (Nitrile)	Back-up ring NBR (Nitrile)
1/4"	JT020112N0674	4118006
3/8"	JT020115N0674	4118005
1/2"	JT020211N0674	50-140-4
3/4"	JT020123N0674	4138001
1"	JT020126N0674	4148002



ISO 7241-1-A	Steel	3/8" and 1/2"	31.5 MPa	-25°C + 110°C	NBR (nitrile)	"Push-Pull"	Ball or poppet	No	Ball locking mechanism	BSPP NPTF Metric

Main characteristics

- Meets the requirements of ISO 7241-1 Series A
- Modular construction : broad choice of end configurations (BSPP, NPTF and metric)

Applications

- Used for a wide variety of agricultural applications: tractors, accessories...
- Mobile and construction equipment
- Industrial equipment



Technical features

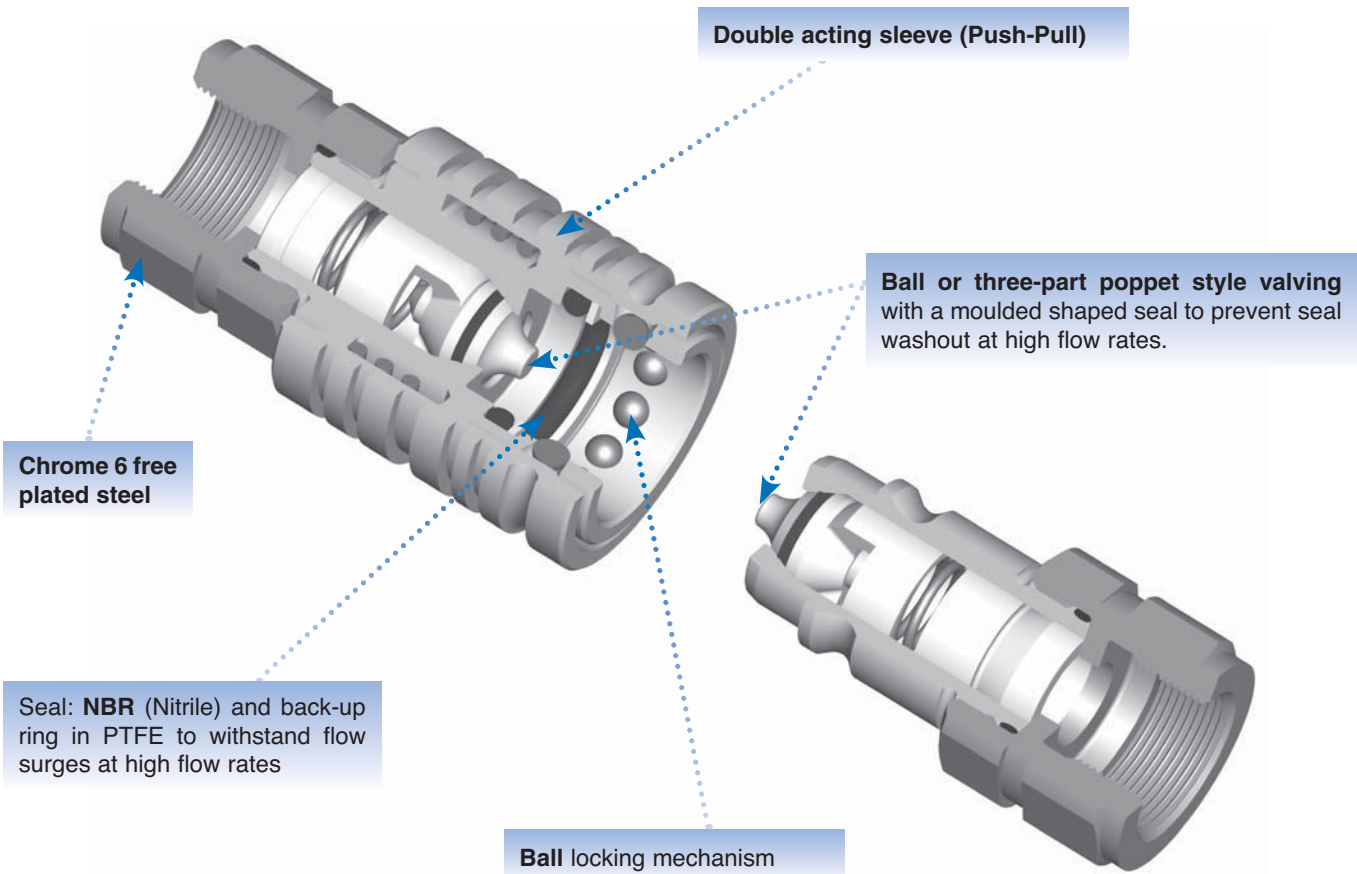

Technical performance data

Body size inch	Temperature range	Max. operating pressure (MPa)
Poppet valving		
3/8"	-25°C +110°C	31.5
1/2"		25.0
Ball valving		
1/2"	-25°C +110°C	21.0

Pressure drop

Test with oil viscosity 28 cSt at 40°C

Poppet Valving

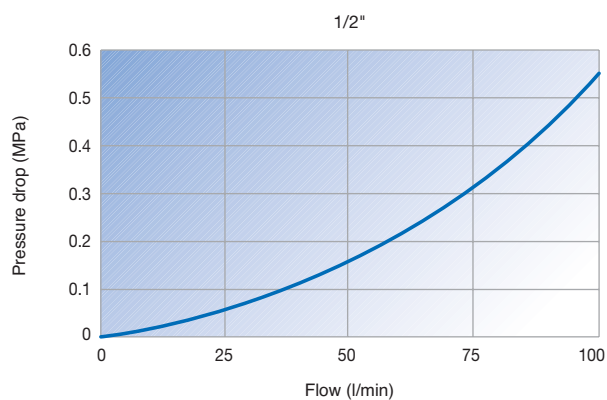
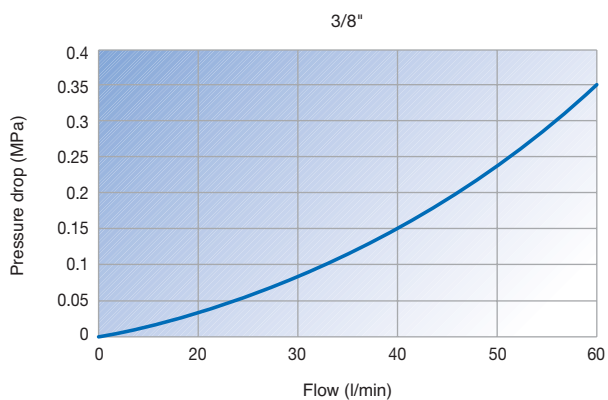

Ball Valving

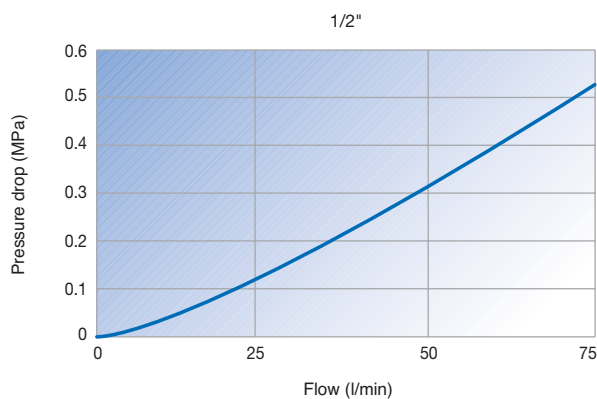

Dimensions and part numbers

24° Cone - DIN 2353

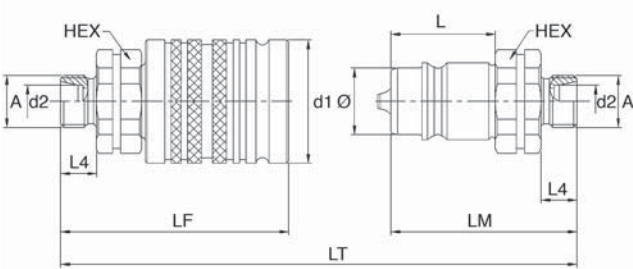

Body size inch	Series	Tube O/D d2	Thread A mm	d1 mm	Hex mm	LF mm	L mm	LM mm	LT connected mm	L4 mm	Ø mm	Part number female body	Weight gr./piece	Part number male tip	Weight gr./piece
Male metric thread															
3/8"	L*	8	M14x1.5	31.0	22.0	65.0	23.0	47.0	94.0	10.0	17.3	4V53D6X2-B	194	4V13D6X2-B	75
	L*	10	M16x1.5	31.0	22.0	66.0	23.0	48.0	96.0	11.0	17.3	4V53D6X3-B	196	4V13D6X3-B	77
	S**	10	M18x1.5	31.0	22.0	67.0	23.0	49.0	98.0	11.0	17.3	4V53D7X3-B	201	4V13D7X3-B	82
1/2"	L*	8	M14x1.5	38.0	30.0	69.0	32.0	56.0	103.0	10.0	20.5	4V54D6X2-B	293	4V14D6X2-B	136
	L*	10	M16x1.5	38.0	30.0	70.0	32.0	57.0	105.0	11.0	20.5	4V54D6X3-B	295	4V14D6X3-B	137
	L*	12	M18x1.5	38.0	30.0	70.0	32.0	57.0	105.0	11.0	20.5	4V54D6X4-B	295	4V14D6X4-B	138
	L*	15	M22x1.5	38.0	30.0	71.0	32.0	58.0	107.0	12.0	20.5	4V54D6X5-B	300	4V14D6X5-B	143
	L*	18	M26x1.5	38.0	30.0	71.0	32.0	58.0	107.0	12.0	20.5	4V54D6X6-B	306	4V14D6X6-B	148
	S**	10	M18x1.5	38.0	30.0	71.0	32.0	58.0	107.0	12.0	20.5	4V54D7X3-B	302	4V14D7X3-B	145
	S**	12	M20x1.5	38.0	30.0	71.0	32.0	58.0	107.0	12.0	20.5	4V54D7X4-B	302	4V14D7X4-B	145
	S**	16	M24x1.5	38.0	30.0	73.0	32.0	60.0	111.0	14.0	20.5	4V54D7X6-B	309	4V14D7X6-B	151

* Light series
** Heavy series

24° Cone - DIN 2353 - Bulkhead

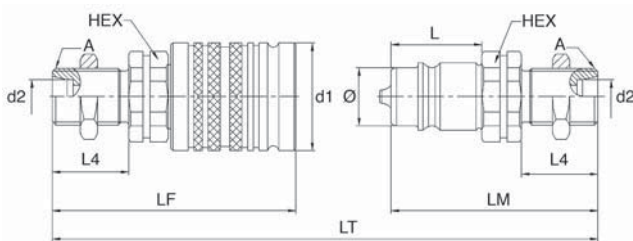

Body size inch	Series	Tube O/D d2	Thread A mm	d1 mm	Hex mm	LF mm	L mm	LM mm	LT connected mm	L4 mm	Ø mm	Part number female body	Weight gr./piece	Part number male tip	Weight gr./piece
Male metric thread															
3/8"	L*	10	M16x1.5	31.0	22.0	81.0	23.0	63.0	126.0	26.0	17.3	4V53E6X3-B	208	4V13E6X3-B	98
1/2"	L*	8	M14x1.5	38.0	30.0	85.0	32.0	72.0	135.0	26.0	20.5	4V54E6X2-B	314	4V14E6X2-B	156
	L*	10	M16x1.5	38.0	30.0	85.0	32.0	72.0	135.0	26.0	20.5	4V54E6X3-B	319	4V14E6X3-B	162
	L*	12	M18x1.5	38.0	30.0	85.0	32.0	72.0	135.0	26.0	20.5	4V54E6X4-B	325	4V14E6X4-B	166
	L*	15	M22x1.5	38.0	30.0	86.0	32.0	73.0	137.0	27.0	20.5	4V54E6X5-B	347	4V14E6X5-B	190
	L*	18	M26x1.5	38.0	30.0	86.0	32.0	73.0	137.0	27.0	20.5	4V54E6X6-B	380	4V14E6X6-B	222
	S**	10	M18x1.5	38.0	30.0	86.0	32.0	73.0	137.0	27.0	20.5	4V54E7X3-B	334	4V14E7X3-B	176
	S**	12	M20x1.5	38.0	30.0	86.0	32.0	73.0	137.0	27.0	20.5	4V54E7X4-B	344	4V14E7X4-B	186
	S**	16	M24x1.5	38.0	30.0	88.0	32.0	75.0	141.0	29.0	20.5	4V54E7X6-B	366	4V14E7X6-B	208

* Light series
** Heavy series

Dimensions and part numbers

Male BSPP thread - DIN 3852 - Form B

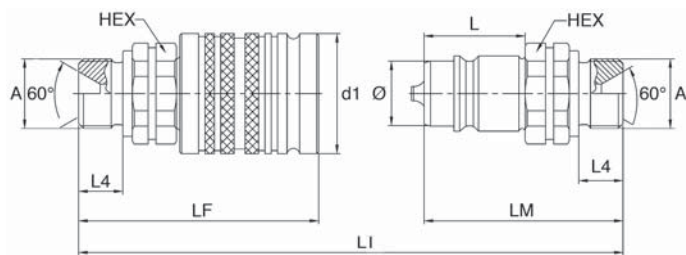

Body size inch	Thread A inch	d1 mm	Hex mm	LF mm	L mm	LM mm	LT connected mm	L4 mm	Ø mm	Part number female body	Weight gr./piece	Part number male tip	Weight gr./piece
Male BSPP thread													
3/8"	3/8	31.0	22.0	74.0	23.0	56.0	112.0	12.0	17.3	4V53F4B3-B	195	4V13F4B3-B	75
1/2"	3/8	38.0	30.0	73.0	32.0	60.0	111.0	12.0	20.5	4V54F4B3-B	327	4V14F4B3-B	146
	1/2	38.0	30.0	76.0	32.0	63.0	117.0	14.0	20.5	4V54F4B4-B	311	4V14F4B4-B	154

Female thread - DIN 3852 - Form Y

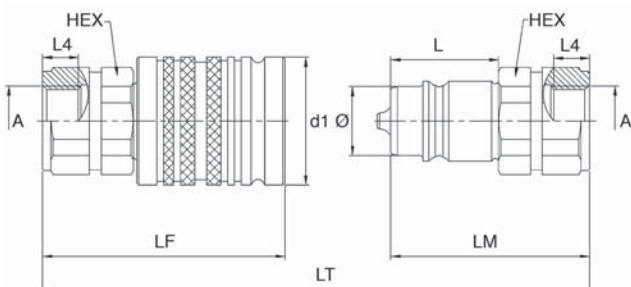

Body size inch	Thread A inch	d1 mm	Hex mm	LF mm	L mm	LM mm	LT connected mm	L4 mm	Ø mm	Part number female body	Weight gr./piece	Part number male tip	Weight gr./piece
Female BSPP thread													
3/8"	3/8	31.0	22.0	67.0	23.0	49.0	98.0	12.0	17.3	4V53G4X3-B	203	4V13G4X3-B	84
1/2"	3/8	38.0	30.0	72.0	32.0	59.0	109.0	12.0	20.5	4V54G4X3-B	327	4V14G4X3-B	168
	1/2	38.0	27.0	70.0	32.0	48.0	96.0	12.0	20.5	4V54G4X4-B	324	4V14G4X4-B	164
	1/2	38.0	27.0	70.0	32.0	48.0	96.0	12.0	20.5	4054G4X4-B*	304	4014G4X4-B*	101
	3/4	38.0	36.0	77.5	32.0	64.5	120.0	16.5	20.5	4V54G4X6-B	374	4V14G4X6-B	217
Female metric thread													
1/2"	M18x1.5	38.0	30.0	72.0	32.0	59.0	109.0	12.5	20.5	4V54G8X5-B	322	4V14G8X5-B	165
	M22x1.5	38.0	30.0	72.0	32.0	59.0	109.0	14.5	20.5	4V54G8X6-B	315	4V14G8X6-B	157
Female NPTF thread													
1/2"	1/2NPT	38.0	27.0	70.0	32.0	48.0	96.0	15.0	20.5	4054G0Z4-B*	308	4014G0Z4-B*	104

* Ball valving

Dust caps and plugs

Plastic



Rubber



Steel



Body size inch	Dust plug part number for female body	Dust cap part number for male tip
Plastic		
3/8"	5025-3PR	5029-3PR
1/2"	5025-4P*	5029-4P*
Rubber		
1/2"	5205-4M	5209-4M
Steel		
1/2"	5005-4	5009-4

* Colour code

B = blue

O = orange

G = green

Y = yellow

R = red

BL = black

Automatic dust cap for female body

Plastic

Body size inch	Cap part number for female body
1/2"	DFE-501-P



Note : Standard dust cap is black. Please consult us for other colours.

Replacement seals

The KIT contains the O-ring in NBR (nitrile) and the back-up ring in PTFE.

Body size inch	Part number
3/8"	4V53-KIT
1/2"	4V54-KIT1
1/2"	4V54-KIT2*



*KIT 2 is for part numbers 4V54G4X4 and 4O54G4X4. For the other part numbers, use KIT 1.

ISO 7241-1-A and ISO 5675	Steel	1/2"	25 MPa max	-30°C + 110°C	NBR (nitrile)	"Push-Pull"	Poppet	Yes in the male tip up to 25 MPa	Ball locking mechanism	Metric, UNF

Main characteristics

- Rigid coupler which meets the requirements of **ISO 7241-1 Series A** and **ISO 5675**
- This coupler is a reference for the most important manufacturers of agricultural equipment
- Must be used with a male tip which meets the requirements of **ISO 7241-1-A**
- Optional: connect under max. operating pressure on the female side (please contact us)

Applications

- Medium and high power tractors: direct mounting on the directional valve or rigid piping



Technical features

Zinc plated steel with a yellow chromate finish

Integrated detent system to prevent circuit shut off in back-flow condition (150 l./min. with 190 l./min. max from the male tip to the female body)

Seal: **NBR** (Nitrile) and back-up ring of filled PTFE to withstand flow surges at high flow rates

Rigid coupling with a double acting sleeve ("Push-Pull"). One hand connection and disconnection: push or pull on male tip to connect or disconnect. Automatic disconnection in case of strong accidental traction on the hose.

Ball locking mechanism

Valving: **three-part poppet** with moulded shaped seal

Technical performance data

Body size inch	Temperature range	Max. operating pressure MPa	Min. burst pressure* MPa
1/2"	-30°C + 110°C	25	129

*According to ISO 5675

Pressure drop

Tests with oil viscosity 43 cSt at 38°C.

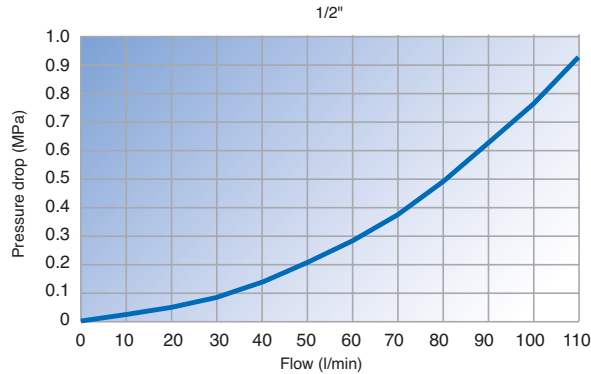

Dimensions and part numbers

Male thread to ISO 6149-2

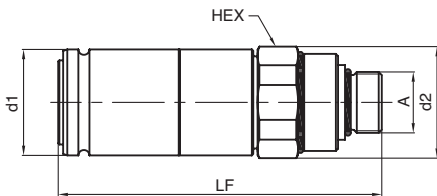

Body size inch	Thread A mm	d1 mm	Hex mm	LF mm	d2 mm	Part number	Weight gr./piece
1/2"	M22x1.5	38	38	117	40	9404-F8H6S2	586

Male metric thread

24° cone bulkhead - DIN 2353 15L - ISO 8434

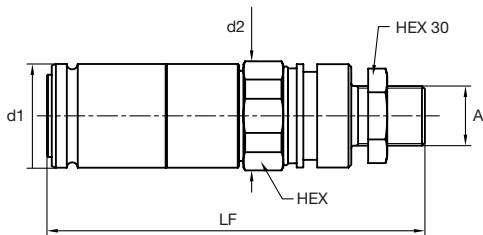

Body size inch	Tube size	Thread A mm	d1 mm	Hex mm	LF mm	d2 mm	Part number	Weight gr./piece
1/2"	15L	M22x1.5	38	38	138.6	40	9404-E6Z5S2	701

Male metric thread

24° cone bulkhead - SAE J514 - ISO 8434-2

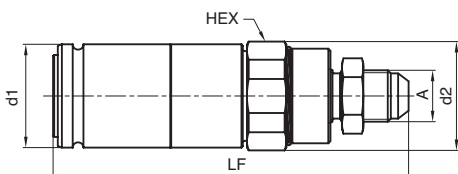

Body size inch	Thread A mm	d1 mm	Hex mm	LF mm	d2 mm	Part number	Weight gr./piece
1/2"	3/4-16	38	38	132	40	9404-T5X4S2	615

Male UNF thread

Dust caps

Single dust cap

Body size inch	LT mm	d1 mm	Dust cap part number
1/2"	85	43	DCP-500*

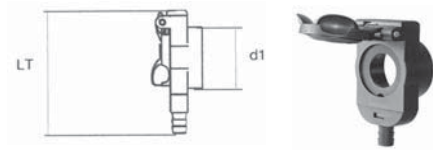

Double dust cap

Body size inch	LT mm	d1 mm	A1 mm	Dust cap part number
1/2"	140	43	55	DCP-555*
	157	43	72	DCP-572*
	167	43	82	DCP-582*

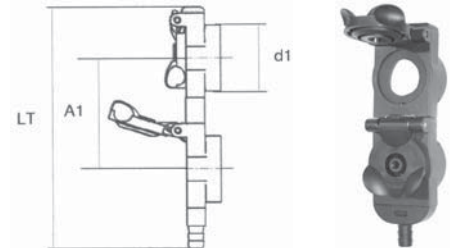

*** Warning:** Coloured plugs are not included in the single and double dust caps but have to be ordered separately.

Coloured plugs

Colour	Part number
Red	9809-018-R
Yellow	9809-018-J
Black	9809-018-N
Green	9809-018-V
Blue	9809-018-B













Note : these dust caps are also suitable for the 1/2" 2000 series.

Replacement seals

Body size inch	O-ring part number NBR (Nitrile)	Back-up ring part number filled PTFE
1/2"	JT020117N0552	4128F002C

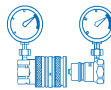

			 max							
ISO 7241-1-A (1/2" only)	Steel	1/4", 3/8" 1/2", 3/4" 1"	20 MPa	-40°C + 110°C	NBR (nitrile)	Manual	Ball or poppet	No	Ball locking mechanism	BSPP, NPTF

Main characteristics

- The 1/2" body size meets the requirements of ISO 7241-1 Series A
- Famous coupling widely held on the market

Applications

- Used for a wide range of forestry and agricultural equipment: tractors, agricultural machinery...
- Construction and mobile equipment
- In-plant machinery



Technical features

Chrome 6 free plated steel

Seal : NBR (Nitrile)

Ball locking mechanism

Single acting sleeve. Connection and disconnection are possible by handling the sleeve

Valving : ball or poppet (as per chart on page 40). The seal is crimped to prevent seal washout at high flow rates

Technical performance data

Body size inch	Temperature range	Max. operating pressure (MPa)
1/4"	-40°C +110°C	20
3/8"		20
1/2"		20
3/4"		20
1"		20

Pressure drop

Tests with oil viscosity 43 cSt at 38°C.

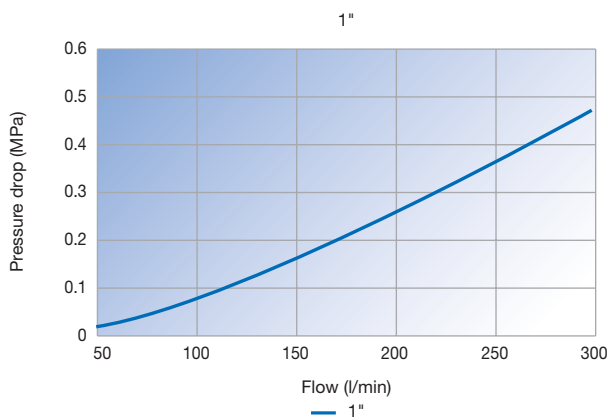
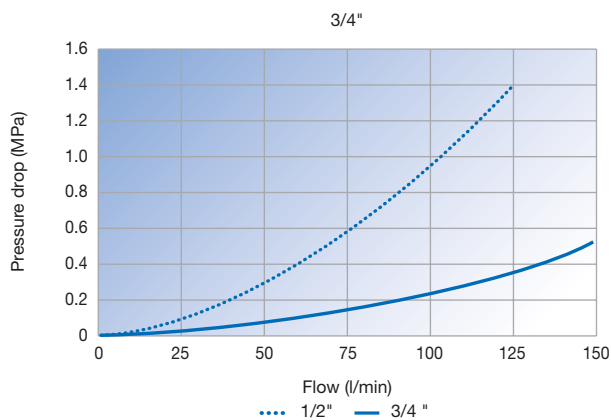
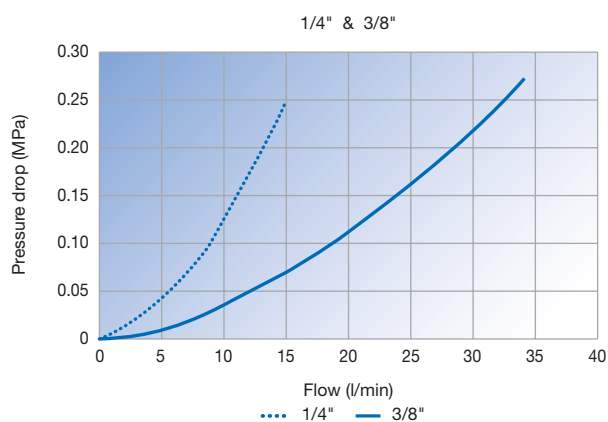

Dimensions and part numbers

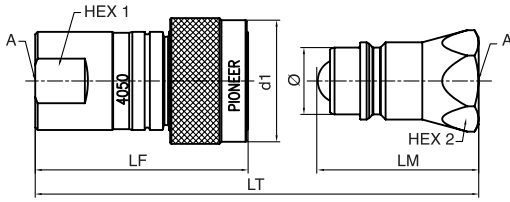

Body size inch	Thread A inch	d1 mm	Hex 1	LF mm	Hex 2	LM mm	LT connected mm	Ø mm	Valving Ball Poppet	Part number female body	Weight gr./piece	Part number male tip	Weight gr./piece
Female NPTF thread													
1/4"	1/4-18	27.0	7/8"	55.4	3/4"	35.3	73.4	14.2	●	4050-2P	110	4010-2P	35
3/8"	3/8-18	33.8	15/16"	58.7	15/16"	38.1	79.0	19.0	●	4050-3P	230	4010-3P	75
1/2"	3/4-14	38.6	1.1/8"	68.3	1.1/4"	54.4	100.8	20.5	●	4050-5	320	8010-5	115
3/4"	3/4-14	48.3	1.3/8"	88.9	1.5/16"	46.0	120.1	26.8	●	4150-5	455	4110-5	130
1"	1-11 1/2	52.8	1.5/8"	97.5	1.5/8"	70.9	135.3	31.3	●	4050-6P	860	4010-6P	280
Female BSPP thread													
1/4"	1/4	27.0	19 mm	55.5	19 mm	38.0	76.0	14.2	●	4050-27-B	125	4010-27-B	35
3/8"	3/8	34.0	24 mm	63.0	24 mm	42.5	85.0	19.0	●	4050-28-B	230	4010-28-B	75

Dust caps and plugs

Rubber



Plastic



Steel











Body size inch	Dust plug part number for female body	Dust cap part number for male tip
Rubber		
1/4"	5205-2M	5209-2M
3/8"	5205-3M	5209-3M
1/2"	5205-4M	5209-4M
3/4"	5205-5M	5209-5M
1"	5205-6M	5209-6M
Plastic		
1/2"	5015-4P*	5019-4P*
Steel		
1/2"	5005-4	5009-4

* Colour code - By ordering, add after the part number the letter corresponding to the colour you wish:

B = blue G = green R = red
O = orange Y = yellow

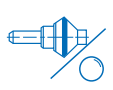
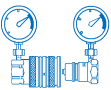
Example: yellow dust cap = 5019-4PY

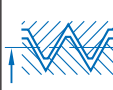
			 max							
Inter-changeable with similar models	Steel	3/8", 1/2", 3/4" & 1"	45 MPa	-25°C + 110°C	NBR (nitrile)	Screw-to connect	Poppet	Yes up to 5 MPa	Screw type	BSP, metric

Main characteristics

- High pressure coupler up to **45 MPa**
- Interchangeable with similar products
- Connection with pressure up to 5 MPa is possible

Applications

- Agricultural and mobile equipment
- Rock hammers
- Forestry equipment
- Snow groomers
- Excavators



Technical features

Black nitrile seal:

- Visual check for correct connection
- Prevents accidental disconnection
- Prevents external contamination entering the system

Three-part poppet style valving with a moulded shaped seal to prevent seal washout at high flow rates

The **sleeve** is mounted on the male tip to protect the sealing area

Chrome 6 free plated steel

Locking: **screw type**. Self locking thread prevents sleeve from being loosened by vibration

Seal: **NBR (Nitrile)** with a PTFE back-up ring to withstand flow surges

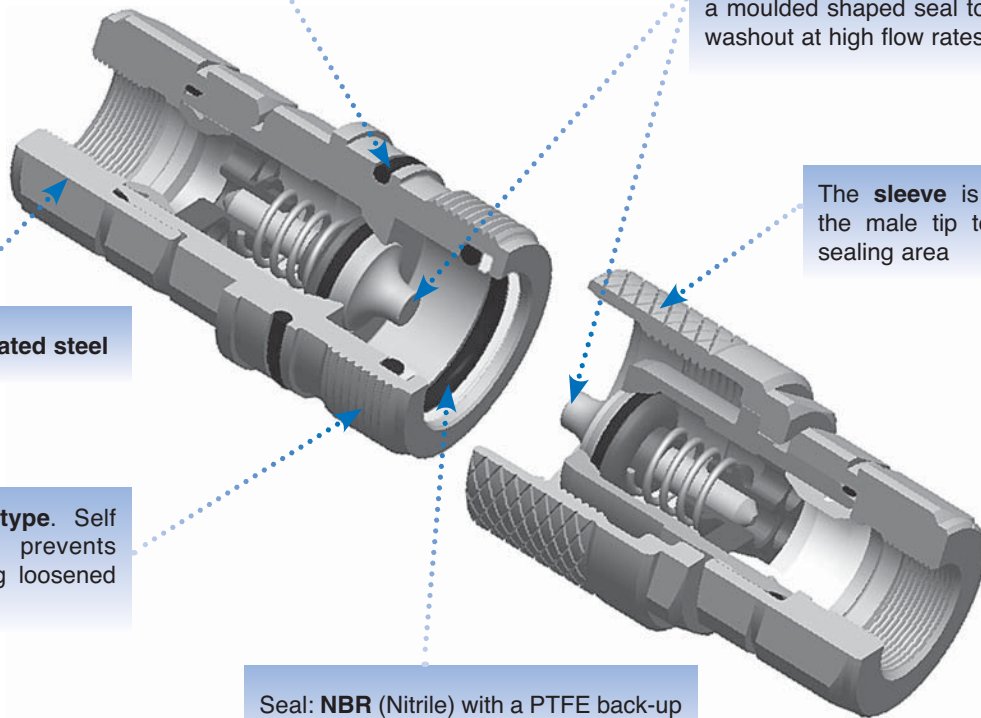

Technical performance data

Body size inch	Temperature range	Max. operating pressure (MPa)
2 3/8"		45.0
3 1/2"	-25°C	40.0
6 3/4"	+110°C	31.5
8 1"		20.0

Be careful !

The maximum operating pressures for couplings with metric adaptors light series (DIN 2353) are 31.5 MPa up to 18L and 16.0 MPa for 22 L

Pressure drop

Test with oil viscosity 28 cSt at 40°C

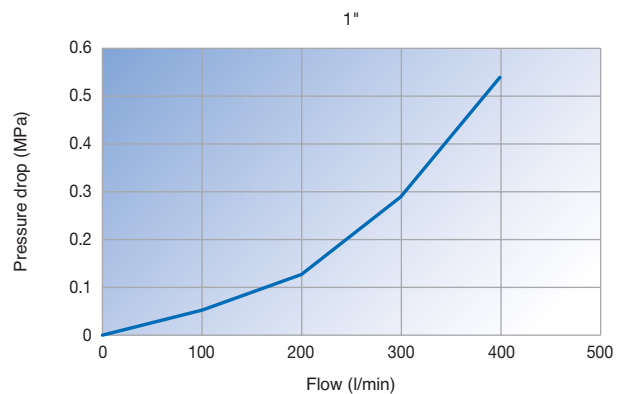
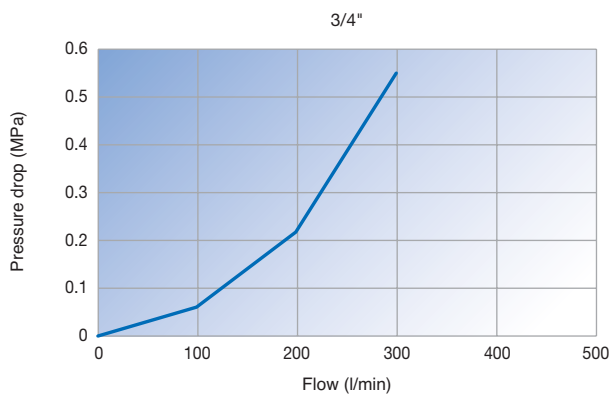
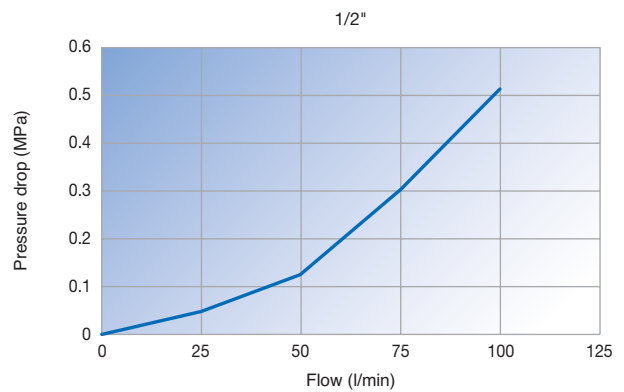
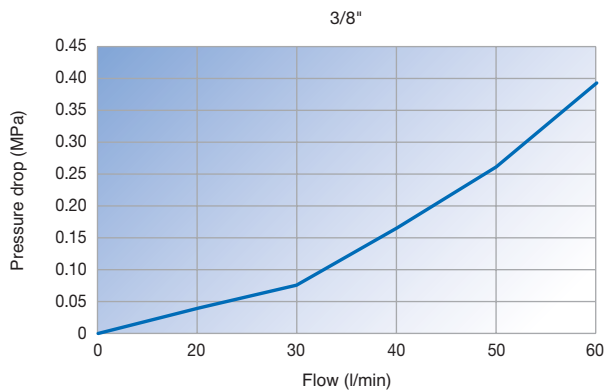

Dimensions and part numbers

24° cone - DIN 2353

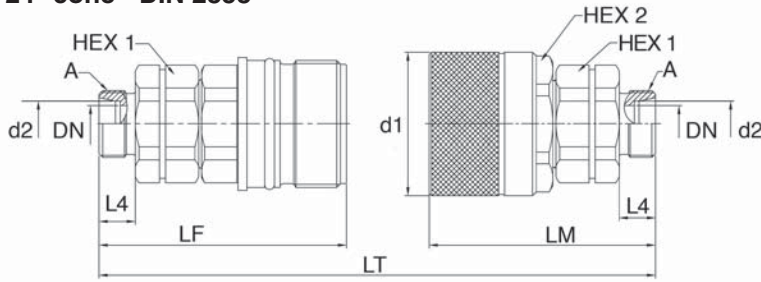

Body size inch	Series	Tube O/D d2	Thread A mm	d1 mm	Hex 1 mm	Hex 2 mm	LF mm	LM mm	LT connected mm	L4 mm	Part number female body	Weight gr./piece	Part number male tip	Weight gr./piece
Male metric thread														
2 3/8"	L*	8	M14x1.5	34.0	22.0	30.0	62.0	59.0	94.0	10.0	QHPA53-D6X2-B	147	QHPA13-D6X2-B	153
	L*	10	M16x1.5	34.0	22.0	30.0	63.0	60.0	96.0	11.0	QHPA53-D6X3-B	148	QHPA13-D6X3-B	154
	S**	10	M18x1.5	34.0	22.0	30.0	64.0	61.0	98.0	12.0	QHPA53-D7X3-B	154	QHPA13-D7X3-B	160
	S**	12	M20x1.5	34.0	22.0	30.0	64.0	61.0	98.0	12.0	QHPA53-D7X4-B	156	QHPA13-D7X4-B	162
3 1/2"	L*	12	M18x1.5	42.0	30.0	36.0	65.0	62.0	99.0	11.0	QHPA54-D6X4-B	285	QHPA14-D6X4-B	242
	L*	15	M22x1.5	42.0	30.0	36.0	66.0	63.0	101.0	12.0	QHPA54-D6X5-B	290	QHPA14-D6X5-B	247
	S**	14	M22x1.5	42.0	30.0	36.0	68.0	65.0	105.0	14.0	QHPA54-D7X5-B	277	QHPA14-D7X5-B	254
	S**	16	M24x1.5	42.0	30.0	36.0	68.0	65.0	105.0	14.0	QHPA54-D7X6-B	298	QHPA14-D7X6-B	255
6 3/4"	L*	18	M26x1.5	55.0	41.0	50.0	93.0	80.0	138.0	12.0	QHPA56-D6X6-B	729	QHPA16-D6X6-B	656
	L*	22	M30x2	55.0	41.0	50.0	95.0	82.0	142.0	14.0	QHPA56-D6X7-B	736	QHPA16-D6X7-B	663
	S**	20	M30x2	55.0	41.0	50.0	97.0	84.0	146.0	16.0	QHPA56-D7X7-B	747	QHPA16-D7X7-B	674
	S**	25	M36x2	55.0	41.0	50.0	99.0	86.0	150.0	18.0	QHPA56-D7X8-B	765	QHPA16-D7X8-B	592
8 1"	S**	30	M42x2	85.0	55.0	80.0	121.7	117.0	184.0	20.0	QHPA58-D7X9-B	1572	QHPA18-D7X9-B	2082

* Light series
** Heavy series

24° cone - DIN 2353 - Bulkhead

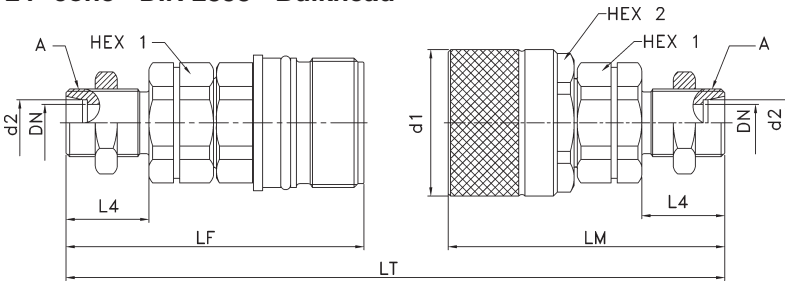

Body size inch	Series	Tube O/D d2	Thread A mm	d1 mm	Hex 1 mm	Hex 2 mm	LF mm	LM mm	LT connected mm	L4 mm	Part number male tip	Weight gr./piece	Part number female body	Weight gr./piece
Male metric thread														
2 3/8"	L*	8	M14x1.5	34.0	22.0	30.0	78.0	75.0	126.0	26.0	QHPA53-E6X2-B	167	QHPA13-E6X2-B	173
	L*	10	M16x1.5	34.0	22.0	30.0	78.0	75.0	126.0	26.0	QHPA53-E6X3-B	179	QHPA13-E6X3-B	173
	S**	10	M18x1.5	34.0	22.0	30.0	79.0	76.0	128.0	27.0	QHPA53-E7X3-B	188	QHPA13-E7X3-B	194
	S**	12	M20x1.5	34.0	22.0	30.0	79.0	76.0	128.0	27.0	QHPA53-E7X4-B	198	QHPA13-E7X4-B	204
3 1/2"	L*	12	M18x1.5	42.0	30.0	36.0	80.0	77.0	129.0	26.0	QHPA54-E6X4-B	313	QHPA14-E6X4-B	270
	L*	15	M22x1.5	42.0	30.0	36.0	81.0	78.0	131.0	27.0	QHPA54-E6X5-B	337	QHPA14-E6X5-B	294
	S**	16	M24x1.5	42.0	30.0	36.0	83.0	80.0	135.0	29.0	QHPA54-E7X6-B	356	QHPA14-E7X6-B	313
6 3/4"	L*	18	M26x1.5	55.0	41.0	50.0	115.0	102.0	182.0	34.0	QHPA56-E6X6-B	822	QHPA16-E6X6-B	749
	S**	20	M30x2	55.0	41.0	50.0	117.0	104.0	185.0	36.0	QHPA56-E7X7-B	865	QHPA16-E7X7-B	792
	S**	25	M36x2	55.0	41.0	50.0	119.0	106.0	190.0	38.0	QHPA56-E7X8-B	918	QHPA16-E7X8-B	845
8 1"	S**	30	M42x2	85.0	55.0	80.0	141.7	137.0	224.0	40.0	QHPA58-E7X9-B	1757	QHPA18-E7X9-B	2350

* Light series
** Heavy series

Dimensions and part numbers

Male BSPP thread - DIN 3852 - Form B

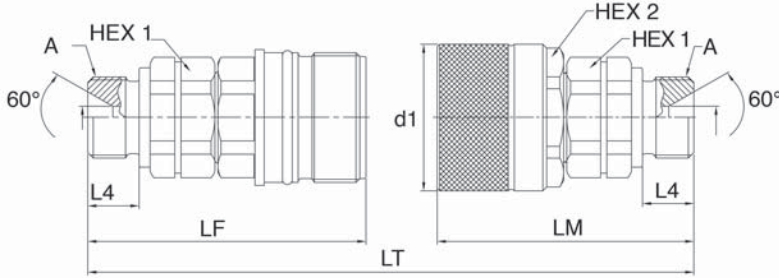

Body size inch	Thread A inch	d1 mm	Hex 1 mm	Hex 2 mm	LF mm	LM mm	LT connected mm	L4 mm	Part number male tip	Weight gr./piece	Part number female body	Weight gr./piece
----------------	---------------	-------	----------	----------	-------	-------	-----------------	-------	----------------------	------------------	-------------------------	------------------

Male BSPP thread

2	3/8"	3/8	34.0	22.0	30.0	66.0	62.0	102.0	12.0	QHPA53-F4A3-B	183	QHPA13-F4A3-B	188
3	1/2"	1/2	42.0	30.0	36.0	71.0	68.0	111.0	14.0	QHPA54-F4A4-B	301	QHPA14-F4A4-B	258

Female BSPP thread - DIN 3852 - Form Y

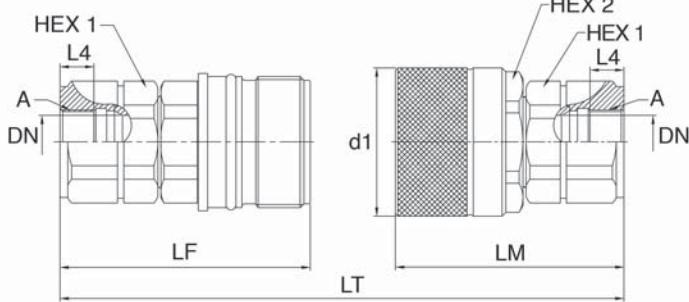

Body size inch	Thread A inch	d1 mm	Hex 1 mm	Hex 2 mm	LF mm	LM mm	LT connected mm	L4 mm	Part number male tip	Weight gr./piece	Part number female body	Weight gr./piece
----------------	---------------	-------	----------	----------	-------	-------	-----------------	-------	----------------------	------------------	-------------------------	------------------

Female BSPP thread

2	3/8"	3/8	34.0	22.0	30.0	64.0	61.0	98.0	12.0	QHPA53-G4X3-B	155	QHPA13-G4X3-B	161
3	1/2"	1/2	42.0	30.0	36.0	67.0	64.0	103.0	12.0	QHPA54-G4X4-B	311	QHPA14-G4X4-B	268
6	3/4"	3/4	55.0	41.0	50.0	100.0	87.0	152.0	16.5	QHPA56-G4X6-B	838	QHPA16-G4X6-B	765
6	3/4"	1	55.0	41.0	50.0	100.0	87.0	152.0	18.0	QHPA56-G4X8-B	786	QHPA16-G4X8-B	713

Dust caps and plugs



Polyethylene

Body size inch	Dust plug part number for male tip	Cap part number for female body
3/8"	QHPA53-DP	QHPA13-DC
1/2"	QHPA54-DP	QHPA14-DC
3/4"	QHPA56-DP	QHPA16-DC
1"	QHPA58-DP	QHPA18-DC

Standard dust caps and plugs are red.

Replacement seals



Body size inch	Part number
3/8"	QHPA53-KIT*
1/2"	QHPA54-KIT*
3/4"	QHPA56-KIT*
1"	QHPA58-KIT*

* The KIT contains the O-ring and the outside ring in NBR (nitrile) as well as the back-up ring in PTFE.

ISO 7241-1-A	Steel	1/2"	25 MPa	-30°C + 110°C	NBR (nitrile)	Manual	Poppet	Yes	Cam mechanism	Metric

Main characteristics

- Meets the requirements of **ISO 7241-1 Series A**
- Possibility of connecting 2 hydraulic lines simultaneously
- No coupling misconnection or accidental disconnection
- Possibility of connecting under pressure up to 25 MPa in one hydraulic line only

Applications

- Agricultural applications: front loaders, hedge cutters...
- Road service vehicles: road service lorries, road sweepers, snowploughs...
- Industrial applications: easy and fast connection and disconnection of implements or tooling

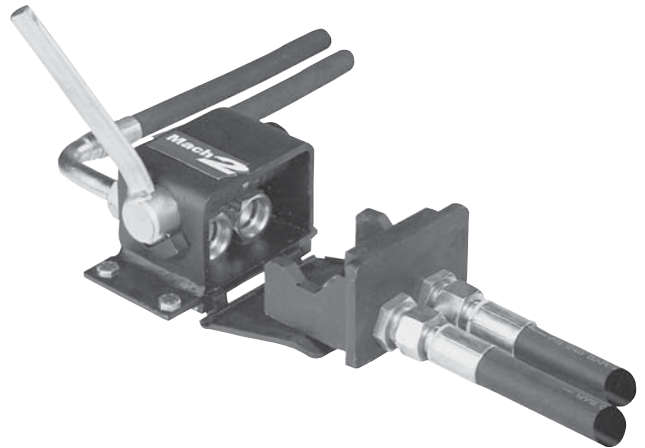

Technical features

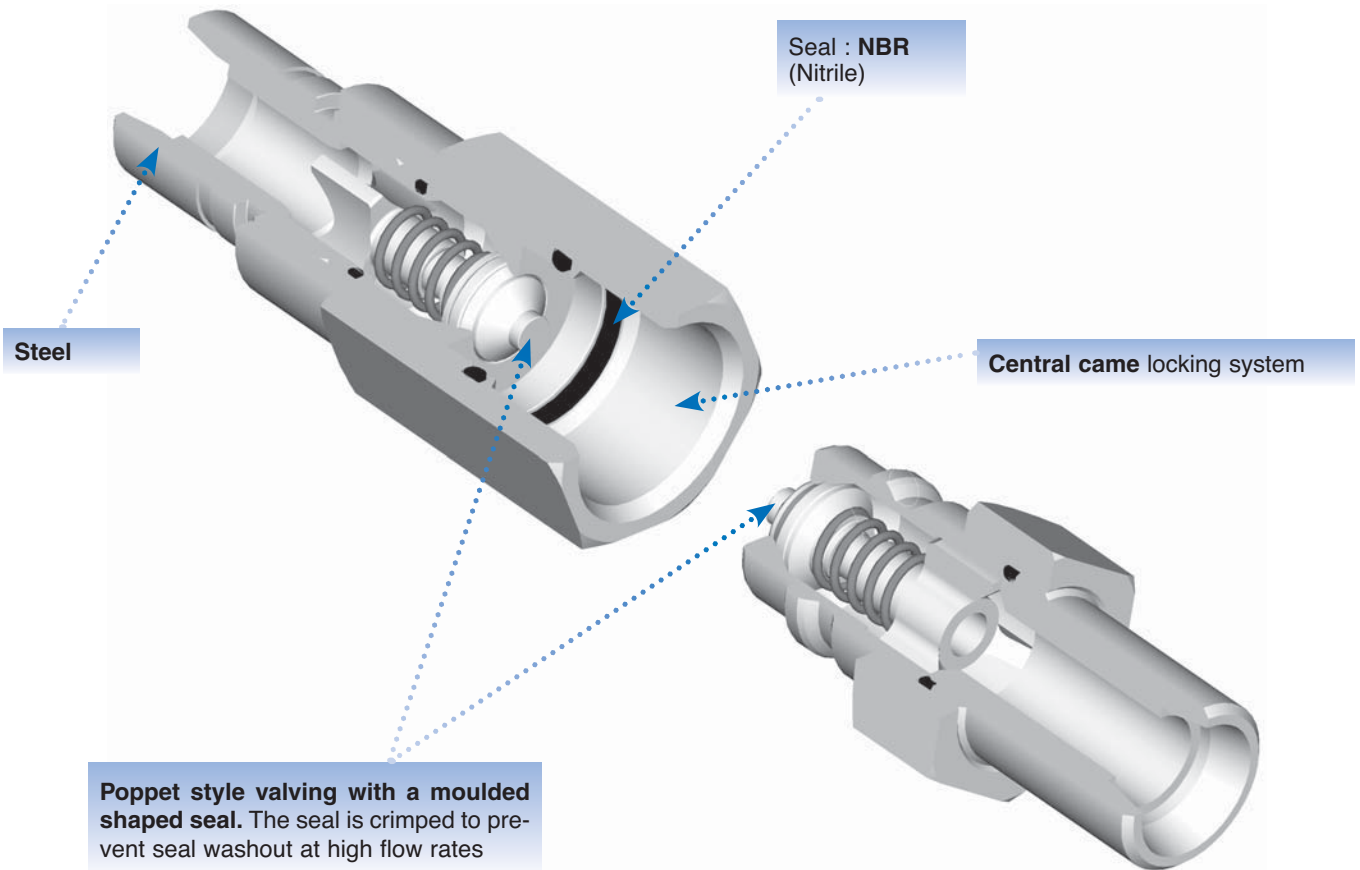

Technical performance data

Body size inch	Temperature range	Max. operating pressure MPa	Min. burst pressure MPa
1/2"	-30°C +110°C	25	96

Pressure drop

Tests with oil viscosity 43 cSt at 38°C.

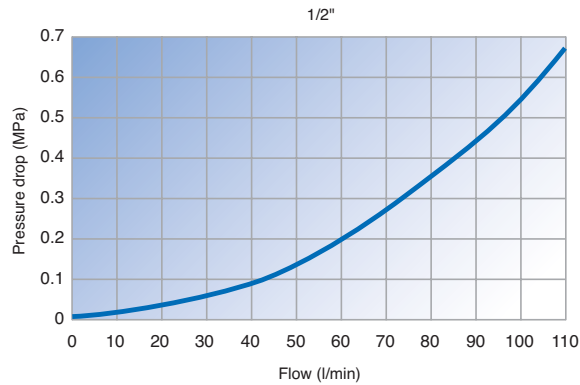

Functioning

Mechanical attachment: 2 mounting holes Ø 8.5 mm

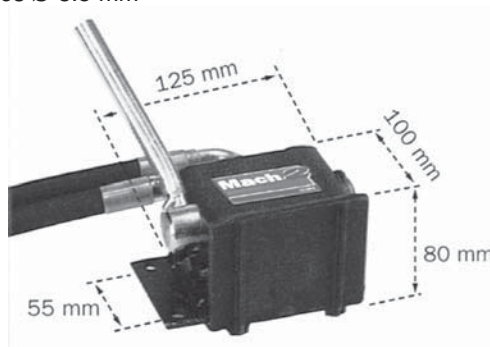

Functioning:

Locating

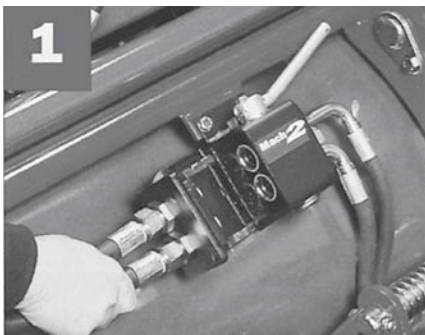

Using one hand, the plug is pushed to open the dust cover and then is introduced into the connecting box.

Locking

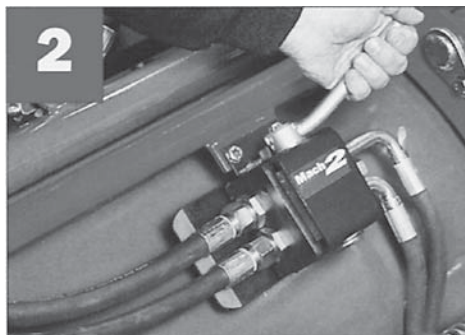

Just move the handle with the other hand.

It is connected

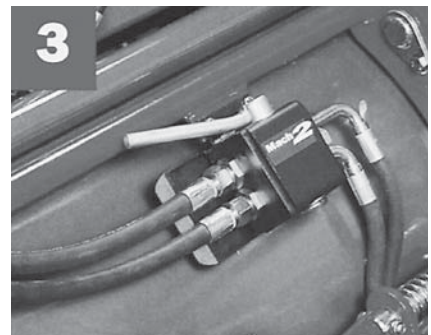

The MACH 2 is connected and locked.

Dimensions and part numbers

Plug :

Description : Complete unit including the connecting plug and 2 male tips, which meet the requirements of ISO 7241-1-A.

Number of hydraulic lines	End configuration	Part number	Weight gr./piece
2	DIN2353-15L (M22x1.5)	MACH2-IA-P	1203

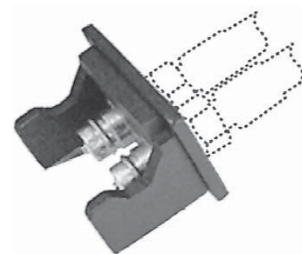

Connecting box:

Description : Complete unit including the base connector unit, its dust cover, a lever acting as a central locking device and 2 female bodies, which meet the requirements of ISO 7241-1-A.



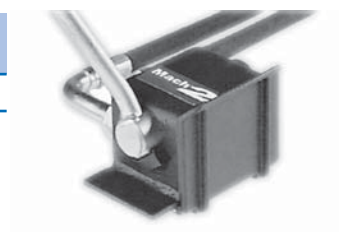







Number of hydraulic lines	End configuration	Part number	Weight gr./piece
2	DIN2353-15L (M22x1.5)	MACH2-IA-B	2723



Note : Other types of MACH 2 with non-spill connections are also available upon request. Please consult us for further information.

Spare parts

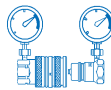
Part	Part number
Female body seal	JT020117N0552
Female body	LV54D6X5MLXC
Male tip	LV14E6X5MLX

			 max							
ISO 7241-1-A	Steel	1/2"	25 MPa	-30°C + 110°C	NBR (nitrile)	Manual	Poppet	Yes	Ball and cam locking mechanism	Metric

Main characteristics

- Meets the requirements of **ISO 7241-1 Series A**
- Possible to connect 4, 5, 6 or 7 hydraulic lines simultaneously
- No coupling misconnection or accidental disconnection
- Using a standard interface will still allow end users to connect their standard quick coupling equipped implements
- In the version with seven lines (MACH 7), the base connector is equipped with an electrical connector as standard feature, which is an option on the MACH 4, 5 and 6.
- Possible to connect with two lines under 20 MPa, if other lines are not under pressure

Applications

- Agricultural applications: front loaders, hedge cutters...
- Road service vehicles: road systems lorries, road sweepers, snowploughs...
- Industrial applications: easy and fast connection and disconnection of implements or tooling



Technical features

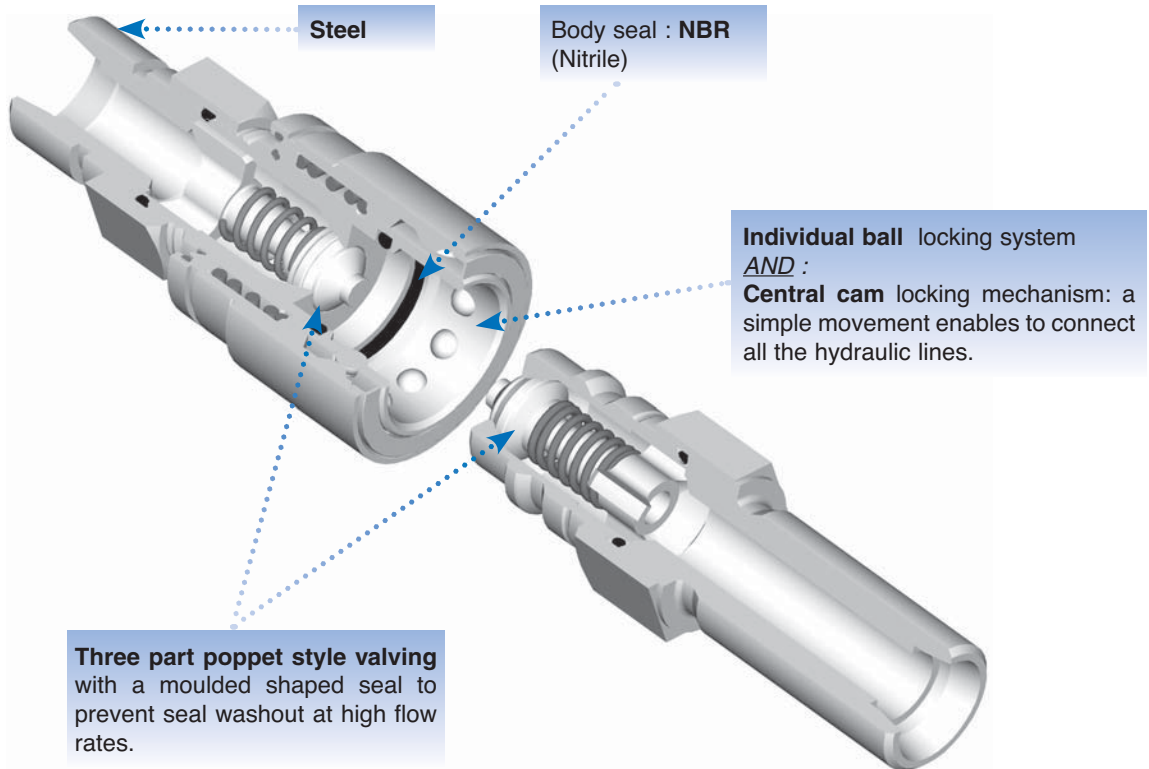

Technical performance data

Body size inch	Temperature range	Max. operating pressure (MPa)	Min. burst pressure (MPa)		
			Connected	female body	male tip
1/2"	-30°C +110°C	25	85	130	80

Pressure drop

Tests with oil viscosity 43 cSt at 38°C.

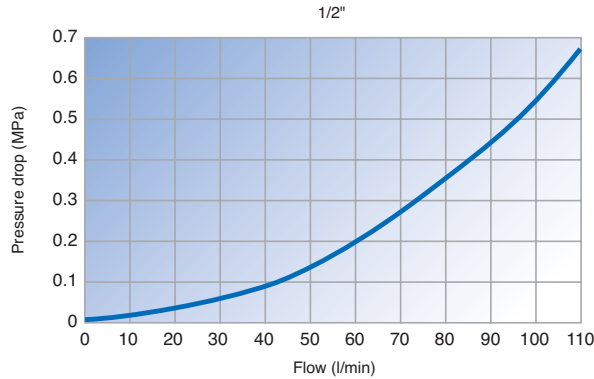

Functioning

Base unit: Mounted with 4 screws M8x1.25 mm.

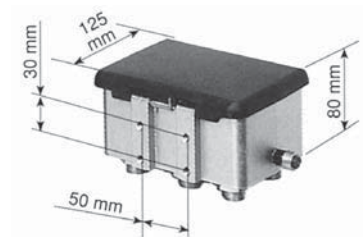

Functioning:

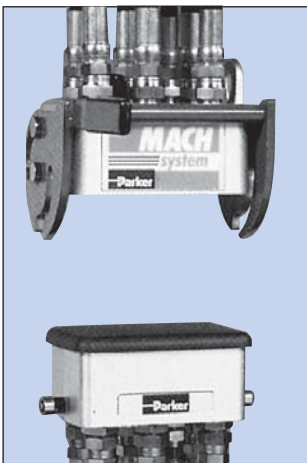

The dust cover is lifted and the top connector put on the base connector. The centring is automatically realised.

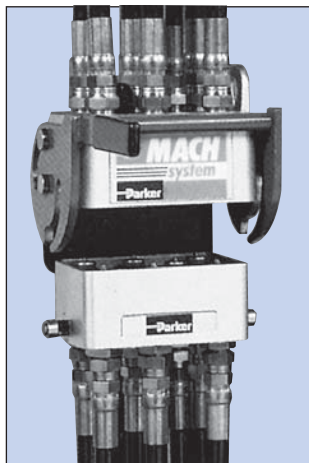

When it is disconnected, the automatic dust cover assures a complete dust and moisture protection of the base connector.



Push down in only one action. It is locked with little effort.

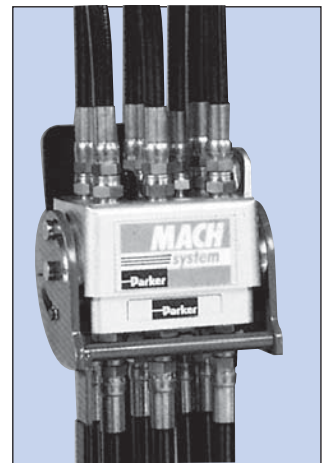

Dimensions and part numbers

Top connectors:

Description : This top connector unit includes the top casting with 4 to 7 female quick couplings and the complete cam locking system. In the most common version with 7 lines, the top connector is also equipped with a 6-line female electrical connector as a standard feature.

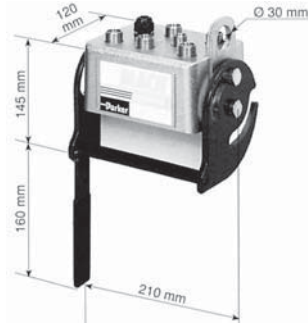

Number of hydraulic lines	Number of threads DIN 2353		Part number without electrical connector	Part number with electrical connector
	15L (M22x1.5)	12L (M18x1.5)		
4	4	0	MACH4/715LT	MACH4/715LTE
5	5	0	MACH5/715LT	MACH5/715LTE
6	6	0	MACH6/715LT	MACH6/715LTE
7	6	1	-	MACH7T

Base connector:

Description : This base connector unit includes the base casting and automatic protective cover, 4 to 7 male quick couplings and the positioning pins. Also included are an adaptor and a plastic hose to drain oil. In the most common version with 7 lines, the base connector is also equipped with a 6 line male electrical connector as a standard feature.

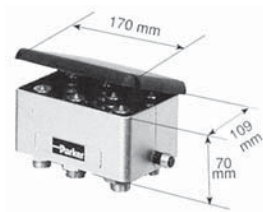

Number of hydraulic lines	Number of threads DIN 2353		Part number without electrical connector	Part number with electrical connector
	15L (M22x1.5)	12L (M18x1.5)		
4	4	0	MACH4/715LB	MACH4/715LBE
5	5	0	MACH5/715LB	MACH5/715LBE
6	6	0	MACH6/715LB	MACH6/715LBE
7	6	1	-	MACH7B

Accessories

Oil drain kit:

Description : This kit includes the removable tank to contain oil spillage and a holding fixture.

Part number
MACH A



Spare parts

Part	Part number
Electrical socket	MACH 8900214
Washer	MACH 8900227
Grommet	MACH 8900226
Electrical plug	MACH 8900213
Snap ring	MACH 7980035
Counter plate	MACH F08767030
Cover	MACH 5400303
Adaptor outside seal	JT020117N0552

Part	End configuration	Part number
Female body	DIN 2353-15L	3V54D6X5MCH
Male tip	DIN 2353-15L	4V14E6X5MCHA
Female body	DIN 2353-12L	3V54D6X4MCH
Male tip	DIN 2353-12L	4V14E6X4MCHA

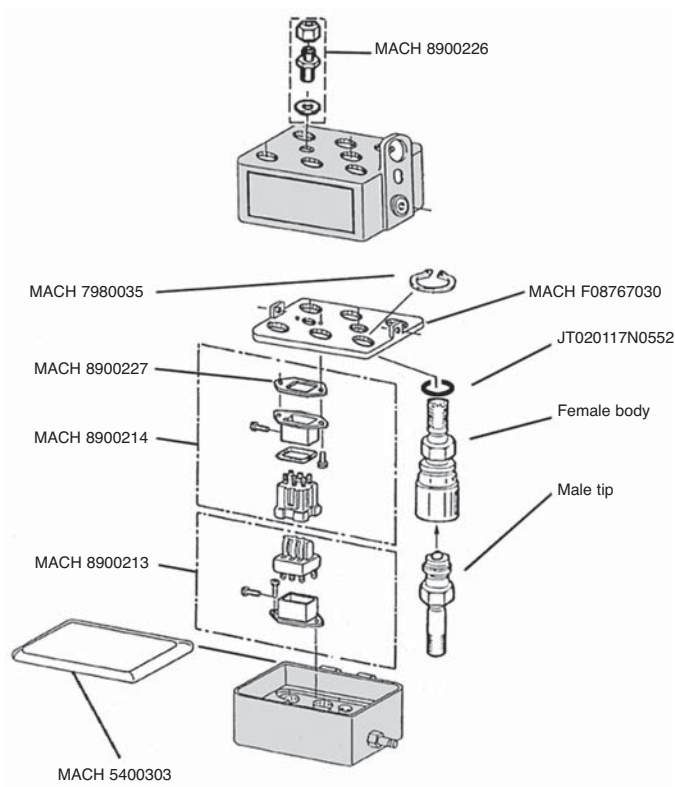

Fluid compatibility chart

The following seal compound and body material compatibility chart is provided as an aid in selecting a specific synthetic rubber compound or body material for a particular application.

Shown here is a list of the seal materials available, with their temperature ranges and the corresponding Parker seal code. Operating and environmental conditions must be considered when making the selection of a quick coupling.

Code used in the part number	Seal material	Temperature range
Without	NBR: Nitrile	-40 + 110°C
W	EPDM: Ethylene Propylene	-50 + 150°C
Y	FKM: Viton™	-25 + 200°C
Z	CR: Neoprene	-50 + 150°C

To indicate a special material just add the appropriate code letter as a suffix to the part number of the coupler. It is not necessary to use the code "STD" as the standard NBR (Nitrile Butadienne Rubber) seal will be used.

For recommendations for media not listed here, please contact your Parker representative.

Note : This chart is intended as a guide only and is not to be considered as a recommendation to use Parker quick couplings in a specific application or with a specific fluid. Other factors that must be considered include but are not limited to: fluid and ambient temperature, system pressure, both operating and peaks, frequency of connection and disconnection, and applicable standards or regulations.

Codes: 1 = satisfactory 2 = fair 3 = not recommended 4 = insufficient data available

Media	Body material				Seal material			
	Brass	Steel	316 S.S.	303 S.S.	NBR (Nitrile)	EPDM (EP)	FKM (Viton™)	CR (Neoprene)
3M FC -75	4	4	4	4	1	1	2	1
Acetamide	4	4	1	2	1	1	3	1
Acetic acid (5%)	3	3	1	1	2	1	1	1
Acetone	1	2	1	1	3	1	3	3
Acetophenone	2	2	2	1	3	1	3	3
Acetyl acetone	2	2	2	2	3	1	3	3
Acetyl chloride	4	2	2	2	3	3	1	3
Acetylene	3	2	1	1	1	1	1	2
Air (100 °C)	1	2	1	1	1	1	1	1
Air (150 °C)	1	2	1	1	2	2	1	2
Air (200 °C)	1	2	1	1	3	3	1	3
Aluminium acetate	4	4	4	4	2	1	3	2
Aluminium bromide	4	4	4	4	1	1	1	1
Aluminium chloride (10%)	3	3	3	3	1	1	1	1
Aluminium chloride (100%)	3	2	2	2	1	1	1	1
Aluminium fluoride	3	3	3	3	1	1	1	1
Aluminium nitrate	3	3	2	2	1	1	1	1
Aluminium salts	4	4	4	4	1	1	1	1
Aluminium sulphate	2	3	2	3	1	1	1	1
Alums (NH3, Cr, K)	4	4	4	4	1	1	3	1
Ammonia (anhydrous)	3	2	1	1	2	1	3	1
Ammonia (cold, gas)	3	2	4	1	1	1	3	1
Ammonia (hot, gas)	3	2	4	1	3	2	3	2
Ammonium carbonate	3	2	3	3	3	1	1	1
Ammonium chloride	3	3	2	3	1	1	1	1
Ammonium hydroxide	3	3	1	2	3	1	3	1
Ammonium nitrate	3	3	1	1	1	1	4	1
Ammonium persulfate solution	3	3	1	2	3	1	4	4
Ammonium phosphate (Mono-, Di-, Tri-basic)	3	3	3	2	1	1	4	1
Ammonium salts	4	4	4	4	1	1	3	1
Ammonium sulphate	3	3	2	3	1	1	3	1
Amyl borate	4	4	4	4	1	3	1	1
Amyl chloride	4	2	1	1	4	3	1	3
Amyl chloronaphtalene	4	4	4	4	3	3	1	3

Appendices

Fluid compatibility chart

Media	Body material				Seal material			
	Brass	Steel	316 S.S.	303 S.S.	NBR (Nitrile)	EPDM (EP)	FKM (Viton™)	CR (Neoprene)
Amyl naphthalene	4	4	4	4	3	3	1	3
Animal oil (lard oil)	2	2	2	2	1	2	1	2
Aroclor 1248	2	3	3	3	3	2	1	3
Aroclor 1254	2	3	3	3	3	2	1	3
Aroclor 1260	2	3	3	3	1	4	1	1
Aromatic fuel -50%	4	4	4	4	2	3	1	3
Arsenic acid	3	3	1	1	1	1	1	1
Asphalt	3	3	1	1	2	3	1	2
ASTM oil, n° 1	1	1	1	1	1	3	1	1
ASTM oil, n° 2	1	1	1	1	1	3	1	2
ASTM oil, n° 3	1	1	1	1	1	3	1	3
ASTM oil, n° 4	1	1	1	1	2	3	1	3
ASTM reference fuel A	3	2	1	1	1	3	1	2
ASTM reference fuel B	3	2	1	1	1	3	1	3
ASTM reference fuel C	3	2	1	1	2	3	1	3
Automotive brake fluid	4	4	4	4	3	1	3	2
Barium chloride	3	3	2	3	1	1	1	1
Barium hydroxide	3	2	2	3	1	1	1	1
Barium salts	4	4	4	4	1	1	1	1
Barium sulphide	3	2	3	3	1	1	1	1
Beer	3	3	1	1	1	1	1	1
Beet sugar liquors	3	3	1	1	1	1	1	2
Benzaldehyde	3	3	2	3	3	1	3	3
Benzene	3	2	3	3	3	3	1	3
Benzenesulfonic acid (10%)	3	3	3	3	3	3	1	2
Benzine	4	4	4	4	1	3	1	2
Benzoic acid	3	3	3	3	3	3	1	3
Benzyl alcohol	4	3	1	2	3	2	1	2
Benzyl chloride	3	3	2	3	3	3	1	3
Bleach liquor	4	4	4	4	3	1	1	2
Borax	3	2	3	3	2	1	1	3
Bordeaux mixture	4	4	4	4	2	1	1	2
Boric acid	3	3	2	3	1	1	1	1
Brake fluid (non-petroleum)	2	2	4	4	3	1	3	2
Brine (sodium chloride)	3	3	1	1	1	1	1	1
Bromine	4	4	4	4	3	3	1	3
Bromine water	4	4	4	4	3	2	1	3
Bunker oil	4	4	4	4	1	3	1	3
Butadiene (monomer)	3	2	1	2	3	3	1	3
Butane	3	1	1	1	1	3	1	1
Butane (2.2 & 2.3-dimethyl)	4	4	4	4	1	3	1	2
Butanol (butyl alcohol)	2	1	1	1	1	2	1	1
Butter (animal fat)	2	3	1	2	1	1	1	2
Butyl butyrate	4	4	4	4	3	1	1	3
Butyl stearate	4	4	4	4	2	3	1	3
Calcine liquors	4	4	4	4	1	1	1	4
Calcium acetate	4	4	4	4	2	1	3	2
Calcium bisulphite	3	3	2	3	2	1	2	2
Calcium carbonate	3	2	3	2	1	1	1	1
Calcium chloride	3	3	2	3	1	1	1	1
Calcium hydroxide	3	3	2	3	1	1	1	1
Calcium hypochlorite	3	3	2	3	2	1	1	2
Calcium salts	4	4	4	4	1	1	1	1
Calcium sulphide	3	3	2	2	1	1	1	1
Caliche liquors	4	4	4	4	1	1	1	1
Cane sugar liquors	4	2	1	1	1	1	1	1
Carbon bisulphide	4	4	4	4	3	3	1	3
Carbon dioxide	1	2	1	1	1	1	1	1
Carbon disulfide	2	2	2	2	3	3	1	3
Carbon monoxide	1	1	1	1	1	1	1	2
Carbon tetrachloride	2	3	1	3	2	3	1	3

Appendices Fluid compatibility chart

Media	Body material				Seal material			
	Brass	Steel	316 S.S.	303 S.S.	NBR (Nitrile)	EPDM (EP)	FKM (Viton™)	CR (Neoprene)
Carbon acid	3	3	1	2	2	1	1	1
Castor oil	1	1	1	1	1	2	1	1
Celluguard	4	4	4	4	1	1	1	1
Cellulube (now fyrquel)	4	4	4	4	3	1	1	3
China wood oil (Tung oil)	2	2	1	1	1	3	1	2
Chlorinated salt brine	4	4	4	4	3	3	1	3
Chlorinated solvents	4	4	4	4	3	3	1	3
Chlorobenzene	3	3	2	3	3	3	1	3
Chlorobutadiene	4	4	4	4	3	3	1	3
Chloroform	3	2	2	1	3	3	1	3
Chlorophenol	4	4	4	4	3	3	1	3
Coconut oil	4	4	4	4	1	3	1	3
Copper chloride	4	4	4	4	1	1	1	2
Copper salts	4	4	4	4	1	1	1	1
Copper sulphate	3	3	2	3	1	1	1	1
Corn oil	2	1	1	1	1	3	1	3
Cottonseed oil	3	2	1	2	1	3	1	3
Creosols	3	2	1	2	3	3	1	3
Creosote	3	3	2	1	1	3	1	2
Cresylic acid	4	2	1	2	3	3	1	3
Crude oil	3	2	1	1	2	3	1	3
Cutting oil	4	1	1	1	1	3	1	2
Decane	4	4	4	4	1	3	1	3
Denatured alcohol	4	4	4	4	1	1	1	1
Detergent (water solution)	3	3	1	1	1	1	1	2
Diesel fuel	1	1	1	1	1	3	1	3
Diethylene glycol	3	1	1	1	1	1	1	1
Dimethyl formamide	4	4	1	1	2	1	3	3
Dow chemical HD50-4	4	4	4	4	4	1	3	2
Dow corning 200, 510, 550	4	4	4	4	2	1	1	1
Dowtherm A, E	3	1	2	2	3	3	1	3
Ethanol	1	3	3	3	3	1	3	1
Ethyl chloride	2	3	1	3	1	3	1	3
Ethyl hexanol	4	4	4	4	1	1	1	1
Ethylene dichloride	3	3	1	2	3	3	1	3
Ethylene glycol	2	2	1	2	1	1	1	1
Fatty acids	3	3	1	2	2	3	1	2
Freon 11	1	4	4	4	2	3	2	3
Freon 12	1	1	3	1	2	3	1	1
Freon 22	1	3	1	1	3	3	3	1
Fuel oil	3	1	1	1	1	3	1	2
Gallic acid	3	3	2	2	2	2	1	2
Gas, liquid, propane (LPG)	1	3	1	1	1	3	1	2
Gas, natural	2	3	1	1	1	3	1	1
Gasoline / petrol	1	2	1	1	1	3	1	3
Gelatine	3	3	1	1	1	1	1	1
Glucose	1	1	1	1	1	1	1	1
Glycerine (glycerol)	2	1	1	1	1	1	1	1
Glycols	3	2	2	2	1	1	1	1
Green sulphate liquor	3	3	3	3	2	1	1	2
Gulf – FR fluid emulsion	4	4	4	4	1	3	1	2
Gulf – FR fluid G	4	4	4	4	1	1	1	1
Gulf – FR fluid P	4	4	4	4	3	2	2	3
Helium	1	1	1	1	1	1	1	1
Heptane	1	1	1	1	1	3	1	2
Hydraulic oil (petroleum base)	1	1	1	1	1	3	1	1
Hydraulic oil (water base)	4	1	1	1	2	1	3	2
Hydrazine	4	3	1	1	2	1	3	2
Hydrogen gas	2	2	1	1	1	1	1	1
Hydrolube	4	4	4	4	1	1	1	2
Iso octane	1	1	1	1	1	3	1	2

Appendices Fluid compatibility chart

Media	Body material				Seal material			
	Brass	Steel	316 S.S.	303 S.S.	NBR (Nitrile)	EPDM (EP)	FKM (Viton™)	CR (Neoprene)
Isobutyl alcohol	4	4	1	1	2	1	1	1
Isopropyl alcohol	1	1	2	1	2	1	1	2
Isopropyl ether	1	1	1	1	2	3	3	3
JP3 and JP4	1	1	1	1	1	3	1	3
Kerosene	1	1	1	1	1	3	1	2
Lard (animal fat)	1	1	1	1	1	2	1	2
Linseed oil	3	1	1	1	1	3	1	3
Lubricating oil SAE 10, 20, 30, 40,50	1	1	1	1	1	3	1	2
Magnesium salts	4	4	4	4	1	1	1	1
Magnesium sulphate	3	3	2	2	1	1	1	1
Mercury	3	3	1	1	1	1	1	1
Methane	1	3	1	1	1	3	1	2
Methanol	1	1	1	1	1	1	3	1
Methyl bromide	4	1	1	1	2	3	1	3
Methyl chloride (wet)	1	3	1	3	3	3	1	3
Methyl chloride (dry)	2	3	1	1	3	3	1	3
Methyl ether	4	4	4	4	1	3	1	3
Methyl ethyl ketone (MEK)	1	1	1	1	3	1	3	3
MIL-F81912 (JP-9)	1	1	1	1	3	3	1	3
MIL-H-5606	1	1	1	1	1	3	1	2
MIL-H-6083	1	1	1	1	1	3	1	1
MIL-H-7083	1	1	1	1	1	1	2	2
MIL-H-8446 (MLO-8515)	2	1	1	1	2	3	1	1
MIL-L-2104 & 2104B	1	1	1	1	1	3	1	2
MIL-L-7808	3	2	1	1	2	3	1	3
Milk	2	1	1	1	1	1	1	1
Mineral oils	1	1	1	1	1	3	1	2
MLO-7277 and MLO-7557	2	1	1	1	3	3	1	3
Mobile HF	1	1	1	1	1	3	1	2
Monomethyl hydrazine	4	4	4	4	2	1	4	2
Naphtha (coal or petroleum)	2	1	2	2	2	3	1	3
Naphthalene	2	1	2	2	3	3	1	3
Naphthenic acid	2	1	2	2	2	3	1	3
Neatsfoot oil	4	4	4	4	1	2	1	3
Nickel acetate	3	2	1	1	2	1	3	2
Nickel chloride	3	3	2	2	1	1	1	2
Nickel salts	4	4	4	4	1	1	1	2
Nickel sulphate	3	3	1	1	1	1	1	1
Nitrogen	1	1	1	1	1	1	1	1
Nitrous oxide	2	2	2	1	1	4	4	4
Octyl alcohol	1	1	1	1	2	3	1	2
Olive oil	2	1	1	1	1	2	1	2
Ortho-dichlorobenzene	2	2	2	2	3	3	1	3
Oxalic acid	3	3	2	1	2	1	1	2
Oxygen (100-200 °C)	1	1	1	1	3	3	2	3
Oxygen (cold)	1	1	1	1	2	1	1	1
Ozone	3	3	1	1	3	1	1	3
Palmitic acid	1	2	1	1	1	2	1	2
Para-dichlorobenzene	2	1	1	2	3	3	1	3
Parker O-Lube	1	1	1	1	1	3	1	1
Peanut oil	2	1	1	1	1	3	1	3
Pentane (2-3 methyl & 2-4 dimethyl)	2	2	2	2	1	3	1	2
Perchloric acid - 2N	3	3	2	2	3	2	1	2
Perchloroethylene	3	2	2	2	2	3	1	3
Petrolatum	1	1	1	1	1	3	1	2
Petroleum oil (below 120 °C)	1	1	1	1	1	3	1	2
Phenol	1	1	1	1	3	3	1	3
Phosphoric acid (3 molar)	3	3	2	2	1	1	1	2
Phosphoric acid (concentrated)	3	3	2	2	3	1	1	3
Phosphorous trichloride	3	3	1	1	3	1	1	3
Picric acid (molten)	3	3	2	2	2	2	1	2

Appendices Fluid compatibility chart

Media	Body material				Seal material			
	Brass	Steel	316 S.S.	303 S.S.	NBR (Nitrile)	EPDM (EP)	FKM (Viton™)	CR (Neoprene)
Picric acid (water solution)	3	3	2	2	1	1	1	1
Pine oil	2	2	1	2	1	3	1	3
Plating solutions (chrome)	1	3	1	1	4	1	1	3
Plating solutions (other)	4	1	1	1	1	1	1	3
Pneumatic service	1	1	1	1	1	1	1	1
Potassium acetate	2	1	2	2	2	1	3	2
Potassium chloride	3	3	1	2	1	1	1	1
Potassium cyanide	3	2	2	2	1	1	1	1
Potassium dichromate	3	1	2	2	1	1	1	1
Potassium hydroxide (50%)	3	2	1	2	2	1	3	2
Potassium nitrate	2	1	1	1	1	1	1	1
Potassium salts	4	4	4	4	1	1	1	1
Potassium sulphate	3	2	1	1	1	1	1	1
PRL - high temp. hydr. oil	4	4	4	4	2	3	1	2
Producer gas	2	1	1	1	1	3	1	2
Propane	1	3	1	1	1	3	1	2
Propyl acetate	3	1	1	1	3	2	3	3
Propyl alcohol	1	1	1	1	1	1	1	1
Propylene	1	1	1	1	3	3	1	3
Pydraul 10E	3	1	1	1	3	1	3	3
Pydraul A-200 (C series)	3	1	1	1	3	3	1	3
Pydraul (3 series)	3	1	1	1	3	1	1	3
Pyrogard 42, 43, 53, 55 (phosphate ester)	4	4	4	4	3	1	1	3
Pyrogard D	4	4	4	4	1	3	3	2
Sea water (salt water)	2	3	1	1	1	1	1	2
Shell irus 905	4	4	4	4	1	3	1	2
Silicone greases	1	1	1	1	1	1	1	1
Silver nitrate	3	3	1	2	2	1	1	1
Skydrol 500 (type 2)	3	1	1	1	3	1	3	3
Skydrol 7000 (type 2)	3	1	1	1	3	1	2	3
Soap solutions	3	3	1	1	1	1	1	2
Sodium acetate	1	1	1	1	2	1	3	2
Sodium bicarbonate	2	2	1	1	1	1	1	1
Sodium bisulphate or bisulphite	3	3	2	1	1	1	1	1
Sodium borate	3	2	2	2	1	1	1	1
Sodium carbonate	4	1	1	1	1	1	1	1
Sodium chloride	3	2	2	2	1	1	1	1
Sodium cyanide	3	1	1	1	1	1	4	1
Sodium hydroxide	3	2	1	2	2	1	2	2
Sodium hydroxide (50%)	3	3	1	2	2	1	2	2
Sodium metaphosphate	2	1	2	2	1	1	1	2
Sodium nitrate	3	2	1	1	2	1	4	2
Sodium perborate	3	3	1	1	2	1	1	2
Sodium peroxide	3	1	2	2	2	1	1	2
Sodium phosphates	1	3	2	1	1	1	1	2
Sodium salts	4	4	4	4	1	1	1	2
Sodium sulphate	3	2	1	1	1	1	1	1
Sodium sulphite & sulphide	3	3	2	3	1	1	1	1
Sodium thiosulphate	3	3	1	2	2	1	1	1
Soybean oil	2	1	1	1	1	3	1	3
Stannous chloride (15 %)	3	3	2	3	1	1	1	1
Steam (below 200 °C)	1	3	1	1	3	1	3	3
Stoddard solvents	2	1	1	1	1	3	1	2
Sucrose solutions	1	1	1	1	1	1	1	2
Sulphur	2	1	1	1	3	1	1	1
Sulphur liquors	1	1	1	1	2	2	1	2
Sulphur (molten)	3	3	1	1	3	3	1	3
Sulphur dioxide (dry)	3	1	1	3	3	1	3	3
Sulphur trioxide (dry)	2	2	2	3	3	2	1	3
Sunsafe	3	1	1	1	1	3	1	2
Tannic acid (10%)	1	3	2	3	1	1	1	2

Appendices Fluid compatibility chart

Media	Body material				Seal material			
	Brass	Steel	316 S.S.	303 S.S.	NBR (Nitrile)	EPDM (EP)	FKM (Viton™)	CR (Neoprene)
Tar (bituminous)	2	1	1	1	2	3	1	3
Tartaric acid	2	3	3	2	1	2	1	2
Terpineol	4	4	4	4	2	3	1	3
Tertiary butyl alcohol	1	1	1	1	2	2	1	2
Tetrachloroethane	4	2	1	2	3	3	1	3
Tetrachloroethylene	3	2	2	4	3	3	1	3
Tetraethyl lead	1	1	1	1	2	3	1	2
Tetraethyl lead (blend)	1	1	1	1	2	3	1	3
Titanium tetrachloride	2	1	2	3	2	3	1	3
Toluene	1	1	1	1	3	3	1	3
Transformer oil	1	1	1	1	1	3	1	2
Transmission fluid (type A)	1	1	1	1	1	3	1	2
Trichloroethane	4	2	1	4	3	3	1	3
Trichloroethylene	3	2	2	2	3	3	1	3
Tricresyl phosphate	4	1	2	2	3	1	2	3
Turbine oil #15 (MIL-L-7808A)	4	2	1	1	2	3	1	3
Turpentine	3	2	1	1	1	3	1	3
Varnish	1	1	1	1	2	3	1	3
Water	1	3	1	1	1	1	2	2
Whiskey	1	3	1	1	1	1	1	1
Wine	1	3	1	1	1	1	1	1
Wood oil	4	2	1	1	1	3	1	2
Xylene	1	2	1	1	3	3	1	3
Zinc sulphate	3	3	2	2	1	1	1	1

SAFETY GUIDE FOR SELECTING AND USING QUICK ACTION COUPLINGS AND RELATED ACCESSORIES



DANGER: failure or improper selection or improper use of quick action couplings or related accessories can cause death, personal injury and property damage. Possible consequences of failure or improper selection or improper use of quick action couplings or related accessories include but are not limited to:

- Couplings or parts thrown off at high speed
- High velocity fluid discharge
- Contact with suddenly moving or falling objects that are to be held in position or moved by the conveyed fluid
- Dangerously whipping hose
- Explosion or burning of the conveyed fluid
- Contact with conveyed fluids that may be hot, cold, toxic, or otherwise injurious
- Sparking or explosion while paint or flammable liquid spraying

Before selecting or using any Parker quick action couplings or related accessories, it is important that you read and follow the following instructions.

1.0 GENERAL INSTRUCTIONS

1.1 Scope: this safety guide provides instructions for selecting and using (including installing connecting, disconnecting, and maintaining) quick action couplings and related accessories (including caps, plugs, blow guns). This safety guide is a supplement to and is to be used with the specific Parker publications for the specific quick action couplings and related accessories that are being considered for use.

1.2 Fail-Safe: quick action couplings or the hose they are attached to can fail without warning for many reasons. Design all systems and equipment in a fail-safe mode, so that failure of the quick action coupling or hose will not endanger persons or property.

1.3 Distribution : provide a copy of this safety guide to each person who is responsible for selecting or using quick action coupling products. Do not select or use quick action couplings without thoroughly reading and understanding this safety guide as well as the specific Parker publications for the products considered or selected.

1.4 User responsibility: due to the wide variety of operating conditions and uses for quick action couplings, Parker and its distributors do not represent or warrant that any particular quick action coupling is suitable for any specific end use system. This safety guide does not analyse all technical parameters that must be considered in selecting a product. The user, through its own analysis and testing, is solely responsible for:

- Making the final selection of the quick action couplings.
- Assuring that the user's requirements are met and that the use presents no health or safety hazards.
- Providing all appropriate health and safety warnings on the equipment on which the quick action couplings are used.

1.5 Additional questions: call the appropriate Parker customer service department if you have any questions or require any additional information. For the telephone numbers of the appropriate customer service department, see the Parker publication for the product being considered or used.

2.0 QUICK ACTION COUPLINGS SELECTION INSTRUCTIONS

2.1 Pressure: quick action couplings selection must be made so that the published rated pressure of the coupling is equal to or greater than the maximum system pressure. Pressure surges in the system higher than the rated pressure of the coupling will shorten the quick action coupling's life. Do not confuse burst pressure or other pressure values with rated pressure and do not use burst pressure or other pressure values for this purpose.

2.2 Fluid compatibility: quick action couplings selection must assure compatibility of the body and seal materials with the fluid media used. See the fluid compatibility chart.

2.2 Temperature: be certain that fluid and ambient temperatures, both steady and transient, do not exceed the limitations of the quick action couplings. Use caution and hand protection when connecting or disconnecting quick action couplings that are heated or cooled by the media they are conducting or by their environment.

2.4 Size: transmission of power by means of pressurised liquid varies with pressure and rate of flow. The size of the quick action couplings and other components of the system must be adequate to keep pressure losses to a minimum and avoid damage due to heat generation or excessive fluid velocity.

2.5 Pressurised connection or disconnection: if connecting or disconnecting under pressure is a requirement, use only quick action couplings designed for that purpose. The rated operating pressure of a quick action coupling may not be the pressure at which it may be safely connected or disconnected.

2.6 Environment: care must be taken to ensure that quick action couplings are either compatible with or protected from the environment (that is, surrounding conditions) to which they are exposed. Environmental conditions including but not limited to ultraviolet radiation, ozone, moisture, water, salt water, chemicals, and air pollutants can cause degradation and premature failure.

2.7 Locking means: ball locking quick action couplings can unintentionally disconnect if they are dragged over obstructions on the end of a hose or if the sleeve is bumped or moved enough to cause disconnection. Sleeves designed with flanges to provide better gripping for oily or gloved hands are especially susceptible to accidental disconnection and should not be used where these conditions exist. Sleeve lock or union (threaded) sleeve designs should be considered where there is a potential for accidental uncoupling.

2.8 Mechanical loads: external forces can significantly reduce quick action couplings' life or cause failure. Mechanical loads which must be considered include excessive tensile or side loads, and vibration. Unusual applications may require special testing prior to quick action couplings selection.

2.9 Specifications and standards: when selecting quick action couplings, government, industry, and Parker specifications must be reviewed and followed as applicable.

2.10 Vacuum: not all quick action couplings are suitable or recommended for vacuum service. Quick action couplings used for vacuum applications must be selected to ensure that the quick action couplings will withstand the vacuum and pressure of the system.

2.11 Fire resistant fluids: some fire resistant fluids require seals other than the standard NBR (nitrile) used in many quick action couplings.

2.12 Radiant heat: quick action couplings can be heated to destruction or loss of sealing without contact by such nearby items as hot manifolds or molten metal. The same heat source may then initiate a fire. This can occur despite the presence of cool air around the quick action couplings.

2.13 Welding and brazing: heating of plated parts, including quick action couplings and port adapters, above 450 °F (232 °C) such as during welding, brazing, or soldering may emit deadly gases and may cause coupling seal damage.

3.0 QUICK ACTION COUPLINGS INSTALLATION INSTRUCTIONS

3.1 Pre-installation inspection: before installing a quick action coupling, visually inspect it and check for correct style, body material, seal material, and catalogue number. Before final installation, coupling halves should be connected and disconnected with a sample of the mating half with which they will be used.

3.2 Quick action coupling halves from other manufacturers: if a quick action coupling assembly is made up of one Parker half and one half from another manufacturer, the lowest pressure rating of the two halves should not be exceeded.

3.3 Fitting installation: use a thread sealant, when assembling taper pipe thread joints in quick action couplings. Be sure the sealant is compatible with the system fluid or gas. To avoid system contamination, use a liquid or paste type sealant rather than a tape style. Use the flats provided to hold the quick action coupling when installing fittings. Do not use pipe wrenches or a vice on other parts of the coupling to hold it when installing or a removing fittings as damage or loosening of threaded joints in the coupling assembly could result. Do not apply excessive torque to taper pipe threads because cracking or splitting of the female component can result.

3.4 Caps and plugs: use dust caps and plugs when quick action couplings are not coupled to exclude dirt and contamination and to protect critical surfaces from damage.

3.5 Coupling location: locate quick action couplings where they can be reached for connection or disconnection without exposing the operator to slipping, falling, getting sprayed, or coming in contact with hot or moving parts.

3.6 Hose whips: use a hose whip (a short length of hose between the tool and the coupling half) instead of rigidly mounting a coupling half on hand tools or other devices. This reduces the potential for coupling damage if the tool is dropped and provides some isolation from mechanical vibration which could cause uncoupling.

4.0 QUICK ACTION COUPLINGS MAINTENANCE INSTRUCTIONS

4.1 Even with proper selection and installation, quick action coupling life may be significantly reduced without a continuing maintenance program. Frequency should be determined by the severity of the application and risk potential. A maintenance program must be established and followed by the user and must include the following as a minimum:

4.2 Visual inspection of quick action couplings: any of the following conditions require immediate shut down and replacement of the quick action coupling:

- Cracked, damaged, or corroded quick action couplings parts.
- Leaks at the fitting, valve or mating seal.
- Broken coupling mounting hardware, especially breakaway clamps.

4.3 Visual inspection all other:

- Leaking seals or port connections.
- Excess dirt build-up on the coupling locking means or on the interface area of either coupling half.
- Defective clamps, guards, and shields.
- System fluid level, fluid type and any entrapment.

4.4 Functional test: operate the system at maximum operating pressure and check for possible malfunctions and freedom from leaks. Personnel must avoid potential hazardous areas while testing and using the system.

4.5 Replacement intervals: specific replacement intervals must be considered based on previous service life, government or industry recommendations, or when failures could result in unacceptable downtime, damage or injury risk. See instruction 1.2 above.

Dimensions

Size of the unit	Tube O/D mm	Tube O/D inch	Dimensions
4	6	1/4	In (") x 25.4 = mm mm ÷ 25.4 = In (")
5	8	5/16	
6	10	3/8	
8	12	1/2	
10	16	5/8	
12	20	3/4	
16	25	1	
20	32	1 1/4	
24	40	1 1/2	
32	50	2	

Weight

Weight

Weight in LB x 453.59 = Weight in grams
Weight in grams ÷ 453.59 = Weight in LB

Flow rate

l/min	UK GPM	US GPM	Flow rate
1	0.2	0.26	l/min x 0.219976 = gal/min (UK) l/min x 0.264218 = gal/min (US)
15	3.3	3.96	
30	6.6	7.93	
45	9.9	11.89	
100	22.0	26.42	
250	55.0	66.05	
500	110.0	132.11	
1000	220.0	264.22	

Pressure

Bar	MPa	PSI	Pressure
1	0.1	14.5	bar x 14.5038 = PSI 1 MPa = 10 bars
6	0.6	87.0	
10	1.0	145.0	
15	1.5	217.5	
20	2.0	290.0	
30	3.0	435.0	
50	5.0	725.0	
100	10.0	1 450.5	
200	20.0	2 900.5	
250	25.0	3 625.0	
500	50.0	7 252.0	
700	70.0	10 152.5	
1000	100.0	14 503.5	
1500	150.0	21 755.0	

Material

Designations used in the catalogue	NF. EN 10088-3	
	Numerical	Symbolical
AISI 302	1.4301	X5 Cr Ni 18-10
AISI 303	1.4305	X8 Cr Ni S 18-9
AISI 316	1.4401	X5 Cr Ni Mo 17-12-2
AISI 316 L	1.4404	X2 Cr Ni Mo 17-12-2
AISI 316 L	1.4435	X2 Cr Ni Mo 18-14-3

Temperature

°F → °C	°F → °C	°C → °F	°C → °F
-40	-40.0	+105	+40.6
-35	-37.2	+110	+43.3
-30	-34.4	+115	+46.1
-25	-31.7	+120	+48.9
-20	-28.9	+125	+51.7
-15	-26.1	+130	+54.4
-10	-23.3	+135	+57.2
-5	-20.6	+140	+60.0
0	-17.8	+145	+62.8
+5	-15.0	+150	+65.6
+10	-12.2	+155	+68.3
+15	-9.4	+160	+71.1
+20	-6.7	+165	+73.9
+25	-3.9	+170	+76.7
+30	-1.1	+175	+79.4
+32	0.0	+180	+82.2
+35	+1.7	+185	+85.0
+40	+4.4	+190	+87.8
+45	+7.2	+195	+90.6
+50	+10.0	+200	+93.3
+55	+12.8	+205	+96.1
+60	+15.6	+210	+98.9
+65	+18.3	+215	+101.7
+70	+21.1	+220	+104.4
+75	+23.9	+225	+107.2
+80	+26.7	+230	+110.0
+85	+29.4	+235	+112.8
+90	+32.2	+240	+115.6
+95	+35.0	+245	+118.3
+100	+37.8	+250	+121.1

Temperature
(°C x 1.8) + 32 = °F
(°F - 32) ÷ 1.8 = °C

Assembly torque

BSP thread (ISO 1179-1 / DIN 3852-T2)

O-Ring with Retaining Ring

Thread G	Series	Tube O/D mm	Assembly torque Nm +10% -0
G 1/8A	L	6	18
G 1/4A	L	8	35
	L	10	35
G 3/8A	L	12	70
G 1/2A	L	15	90
	L	18	90
G 3/4A	L	22	180
G 1A	L	28	310
G 1 1/4A	L	35	450
G 1 1/2A	L	42	540
G 1/4A	S	6	55
	S	8	55
G 3/8A	S	10	80
	S	12	80
G 1/2A	S	14	115
	S	16	115
G 3/4A	S	20	180
G 1A	S	25	310
G 1 1/4A	S	30	450
G 1 1/2A	S	38	540

Note : Lubricate threads before assembly. Tightening torques are for steel fittings assembled in steel components.

Metric thread (ISO 6149 / DIN 3852 -T3)

Series	Thread mm	Assembly torque Nm +10% -0
L	M8x1	8
L	M10x1	15
L	M12x1.5	25
L	M14x1.5	35
L	M16x1.5	40
L	M18x1.5	45
L	M22x1.5	60
L	M27x2	100
L	M33x2	160
L	M42x2	210
L	M48x2	260
L	M60x2	315
S	M8x1	10
S	M10x1	20
S	M12x1.5	35
S	M14x1.5	45
S	M16x1.5	55
S	M18x1.5	70
S	M22x1.5	100
S	M27x2	170
S	M33x2	310
S	M42x2	330
S	M48x2	420
S	M60x2	500

Note : Lubricate threads before assembly. Tightening torques are for steel fittings assembled in steel components.

NPTF thread

Thread inch	TFFT*
1/8-27	2 - 3
1/4-18	2 - 3
3/8-18	2 - 3
1/2-14	2 - 3
3/4-14	2 - 3
1-11 1/2	1.5 - 2.5
1 1/4-11 1/2	1.5 - 2.5
1 1/2-11 1/2	1.5 - 2.5
2-11 1/2	1.5 - 2.5

* Turn From Finger Tight: The proper method of assembling tapered threaded connectors is to assemble them finger tight and then wrench tighten further to the specified number of turns from finger tight (TFFT). Assembly Turns From Finger Tight values for steel, stainless steel and brass fittings.

UNF thread (SAE J 1926/1, ISO 11926)

Size of the unit	Thread inch	Assembly torque Nm +10% -0
2	5/16-24 UNF - 2B	10
3	3/8-24 UNF - 2B	19
4	7/16-20 UNF - 2B	25
5	1/2-20 UNF - 2B	30
6	9/16-18 UNF - 2B	37
8	3/4-16 UNF - 2B	65
10	7/8-14 UNF - 2B	122
12	1 1/16-12 UN - 2B	150
14	1 3/16-12 UN - 2B	197
16	1 5/16-12 UN - 2B	217
20	1 5/8-12 UN - 2B	305
24	1 7/8-12 UN - 2B	340
32	2 1/2-12 UN - 2B	440

Appendices Alpha numeric index

Part number	Page	Part number	Page	Part number	Page	Part number	Page	Part number	Page
3005-2	26	4V14D7X6-B	32	5015-4P	40	BH12-61N-BSPP	10	FEF-372-6FB	14
3005-3	26	4V14E6X2-B	32	5019-4P	40	BH1-60	10	FEF-372-8FB	14
3009-2	26	4V14E6X3-B	32	5025-3PR	34	BH1-60-BSPP	10	FEF-501-12FB	14
3009-3	26	4V14E6X4-B	32	5025-4P	34	BH1-61	10	FEF-501-8FB	14
3010-2	26	4V14E6X4MCHA	51	5029-3PR	34	BH1-61-BSPP	10	FEF-502-12FB	14
3010-2P	26	4V14E6X5-B	32	5029-4P	34	BH2016-60	10	FEF-502-8FB	14
3010-3	26	4V14E6X5MCHA	51	5205-2M	40	BH2016-60-BSPP	10	FEF-621-12FB	14
3010-3P	26	4V14E6X6-B	32	5205-3M	40	BH2016-61	10	FEF-622-12FB	14
3050-2	26	4V14E7X3-B	32	5205-4M	34.40	BH2016-61-BSPP	10	FEF-751-16FB	14
3050-2P	26	4V14E7X4-B	32	5205-5M	40	BH2-60	10	FEF-752-16FB	14
3050-3	26	4V14E7X6-B	32	5205-6M	40	BH2-60-BSPP	10	FEM-1001-20FB	17
3050-3P	26	4V14F4B3-B	33	5209-2M	40	BH2-61	10	FEM-1002-20FB	17
3V54D6X4MCH	51	4V14F4B4-B	33	5209-3M	40	BH2-61-BSPP	10	FEM-251-4FB	17
3V54D6X5MCH	51	4V14G4X3-B	33	5209-4M	34.40	BH3-60	10	FEM-252-4FB	17
4010-27-B	40	4V14G4X4-B	33	5209-5M	40	BH3-60-BSPP	10	FEM-371-16BMCL	18
4010-28-B	40	4V14G4X6-B	33	5209-6M	40	BH3-61	10	FEM-371-16MCL	17
4010-2P	40	4V14G8X5-B	33	6603-12-12	29	BH3-61-BSPP	10	FEM-371-18BMCL	18
4010-3P	40	4V14G8X6-B	33	6603-16-16	29	BH4-60	10	FEM-371-18MCL	17
4010-6P	40	4V53D6X2-B	32	6603-4-4	29	BH4-60-BSPP	10	FEM-371-22BMCL	18
4050-27-B	40	4V53D6X3-B	32	6603-6-6	29	BH4-61	10	FEM-371-22MCL	17
4050-28-B	40	4V53D7X3-B	32	6603-8-10	29	BH4-61-BSPP	10	FEM-371-6FB	17
4050-2P	40	4V53E6X3-B	32	6605-12-12	29	BH6-60	10	FEM-371-8FB	17
4050-3P	40	4V53F4B3-B	33	6605-16-16	29	BH6-60-BSPP	10	FEM-372-16BMCL	18
4050-5	40	4V53G4X3-B	33	6605-4-4	29	BH6-61	10	FEM-372-16MCL	17
4050-6P	40	4V53-KIT	34	6605-6-6	29	BH6-61-BSPP	10	FEM-372-18BMCL	18
4110-5	40	4V54D6X2-B	32	6605-8-10	29	BH8-60	10	FEM-372-18MCL	17
4118005	29	4V54D6X3-B	32	6657-12PL	29	BH8-60-BSPP	10	FEM-372-22BMCL	18
4118006	29	4V54D6X4-B	32	6657-16PL	29	BH8-61	10	FEM-372-22MCL	17
4118007	11	4V54D6X5-B	32	6657-4PL	29	BH8-61-BSPP	10	FEM-372-6FB	17
4128002	11	4V54D6X6-B	32	6657-6PL	29	CFE-1002-P	14.18	FEM-372-8FB	17
4128F002C	37	4V54D7X3-B	32	6657-8PL	29	CFE-252-P	14.18	FEM-501-12FB	17
4138001	29	4V54D7X6-B	32	6659-12PL	29	CFE-372-P	14.18	FEM-501-18BMCL	18
4148001	11	4V54E6X2-B	32	6659-16PL	29	CFE-502-P	14.18	FEM-501-18MCL	17
4148002	29	4V54E6X3-B	32	6659-4PL	29	CFE-622-P	14.18	FEM-501-22BMCL	18
4150-5	40	4V54E6X4-B	32	6659-6PL	29	CFE-752-P	14.18	FEM-501-22MCL	17
4158001	11	4V54E6X5-B	32	6659-8PL	29	CL-251-4FB-PLP	24	FEM-501-8FB	17
4O14G0Z4-B	33	4V54E6X6-B	32	8010-5	40	CL-252-4FB-PLC	24	FEM-502-12FB	17
4O14G4X4-B	33	4V54E7X3-B	32	9404-E6Z5S2	36	CM-251-4FB-PLP	22	FEM-502-18BMCL	18
4O54G0Z4-B	33	4V54E7X4-B	32	9404-F8H6S2	36	CM-252-4FB-PLC	22	FEM-502-18MCL	17
4O54G4X4-B	33	4V54E7X6-B	32	9404-T5X4S2	36	CPC-254	22.24	FEM-502-22BMCL	18
4V13D6X2-B	32	4V54F4B3-B	33	9809-018-B	37	CPP-253	22.24	FEM-502-22MCL	17
4V13D6X3-B	32	4V54F4B4-B	33	9809-018-J	37	DCP-500	37	FEM-502-8FB	17
4V13D7X3-B	32	4V54G4X3-B	33	9809-018-N	37	DCP-555	37	FEM-621-12FB	17
4V13E6X3-B	32	4V54G4X4-B	33	9809-018-R	37	DCP-572	37	FEM-622-12FB	17
4V13F4B3-B	33	4V54G4X6-B	33	9809-018-V	37	DCP-582	37	FEM-751-16FB	17
4V13G4X3-B	33	4V54G8X5-B	33	BH12-60L	10	DFE-501-P	14.18.34	FEM-752-16FB	17
4V14D6X2-B	32	4V54G8X6-B	33	BH12-60L-BSPP	10	FEF-1001-20FB	14	H12-62L	7
4V14D6X3-B	32	4V54-KIT1	34	BH12-60N	10	FEF-1002-20FB	14	H12-62L-BSPP	7
4V14D6X4-B	32	4V54-KIT2	34	BH12-60N-BSPP	10	FEF-251-4FB	14	H12-62N	7
4V14D6X5-B	32	5005-4	34.40	BH12-61L	10	FEF-252-4FB	14	H12-62N-BSPP	7
4V14D6X6-B	32	5009-4	34.40	BH12-61L-BSPP	10	FEF-371-6FB	14	H12-63L	7
4V14D7X3-B	32	50-140-4	29	BH12-61N	10	FEF-371-8FB	14	H12-63L-BSPP	7

Appendices Alpha numeric index

Part number	Page	Part number	Page	Part number	Page	Part number	Page	Part number	Page
H12-63N.....	7	H8-62.....	7	MACH6/715LT.....	50	QHPA53-E6X2-B.....	43	SH4-63-BSPP.....	8
H12-63N-BSPP.....	7	H8-62-BSPP.....	7	MACH6/715LTE.....	50	QHPA53-E6X3-B.....	43	SH6-62.....	8
H12-65.....	11	H8-63.....	7	MACH7B.....	50	QHPA53-E7X3-B.....	43	SH6-62-BSPP.....	8
H12-66.....	11	H8-63-BSPP.....	7	MACH7T.....	50	QHPA53-E7X4-B.....	43	SH6-63.....	8
H1-62.....	7	H8-65.....	11	NSI-251-16MCL.....	20	QHPA53-F4A3-B.....	44	SH6-63-BSPP.....	8
H1-62-BSPP.....	7	H8-65M.....	11	NSI-251-C16MCL.....	20	QHPA53-G4X3-B.....	44	SH8-62.....	8
H1-63.....	7	H8-66.....	11	NSI-252-4MBE.....	20	QHPA53-KIT.....	44	SH8-62-BSPP.....	8
H1-63-BSPP.....	7	H8-66M.....	11	PFE-1001-P.....	14.18	QHPA54-D6X4-B.....	43	SH8-63.....	8
H1-65.....	11	JT01U28-18.72QE.....	26	PFE-251-P.....	14.18	QHPA54-D6X5-B.....	43	SH8-63-BSPP.....	8
H1-65M.....	11	JT020013N0674.....	11	PFE-371-P.....	14.18	QHPA54-D7X5-B.....	43	SSH1-62Y.....	9
H1-66.....	11	JT020013V0747.....	11	PFE-501-P.....	14.18	QHPA54-D7X6-B.....	43	SSH1-62Y-BSPP.....	9
H1-66M.....	11	JT020015N0674.....	11	PFE-621-P.....	14.18	QHPA54-DP.....	44	SSH1-63Y.....	9
H2016-62.....	7	JT020015V0747.....	11	PFE-751-P.....	14.18	QHPA54-E6X4-B.....	43	SSH1-63Y-BSPP.....	9
H2016-62-BSPP.....	7	JT020112N0674.....	29	QHPA13-D6X2-B.....	43	QHPA54-E6X5-B.....	43	SSH2-62Y.....	9
H2016-63.....	7	JT020114N0552.....	26	QHPA13-D6X3-B.....	43	QHPA54-E7X6-B.....	43	SSH2-62Y-BSPP.....	9
H2016-63-BSPP.....	7	JT020115N0674.....	29	QHPA13-D7X3-B.....	43	QHPA54-F4A4-B.....	44	SSH2-63Y.....	9
H2020-62.....	7	JT020116N0674.....	11	QHPA13-D7X4-B.....	43	QHPA54-G4X4-B.....	44	SSH2-63Y-BSPP.....	9
H2020-63.....	7	JT020116V0747.....	11	QHPA13-DC.....	44	QHPA54-KIT.....	44	SSH3-62Y.....	9
H2-62.....	7	JT020117N0552.....	37.47.51	QHPA13-E6X2-B.....	43	QHPA56-D6X6-B.....	43	SSH3-62Y-BSPP.....	9
H2-62-BSPP.....	7	JT020123N0674.....	29	QHPA13-E6X3-B.....	43	QHPA56-D6X7-B.....	43	SSH3-63Y.....	9
H2-63.....	7	JT020126N0674.....	29	QHPA13-E7X3-B.....	43	QHPA56-D7X7-B.....	43	SSH3-63Y-BSPP.....	9
H2-63-BSPP.....	7	JT020211N0674.....	29	QHPA13-E7X4-B.....	43	QHPA56-D7X8-B.....	43	SSH4-62Y.....	9
H2-65.....	11	JT020213N0674.....	11	QHPA13-F4A3-B.....	44	QHPA56-DP.....	44	SSH4-62Y-BSPP.....	9
H2-65M.....	11	JT020213V0747.....	11	QHPA13-G4X3-B.....	44	QHPA56-E6X6-B.....	43	SSH4-63Y.....	9
H2-66.....	11	JT020218N0674.....	11	QHPA14-D6X4-B.....	43	QHPA56-E7X7-B.....	43	SSH4-63Y-BSPP.....	9
H2-66M.....	11	JT020218V0747.....	11	QHPA14-D6X5-B.....	43	QHPA56-E7X8-B.....	43	SSH6-62Y.....	9
H3-62.....	7	JT020222N0674.....	11	QHPA14-D7X5-B.....	43	QHPA56-G4X6-B.....	44	SSH6-62Y-BSPP.....	9
H3-62-BSPP.....	7	JT020222V0747.....	11	QHPA14-D7X6-B.....	43	QHPA56-G4X8-B.....	44	SSH6-63Y.....	9
H3-63.....	7	JT020224N0674.....	11	QHPA14-DC.....	44	QHPA56-KIT.....	44	SSH6-63Y-BSPP.....	9
H3-63-BSPP.....	7	JT020333N0674.....	11	QHPA14-E6X4-B.....	43	QHPA58-D7X9-B.....	43	SSH8-62Y.....	9
H3-65.....	11	LV14E6X5MLX.....	47	QHPA14-E6X5-B.....	43	QHPA58-DP.....	44	SSH8-62Y-BSPP.....	9
H3-65M.....	11	LV54D6X5MLXC.....	47	QHPA14-E7X6-B.....	43	QHPA58-E7X9-B.....	43	SSH8-63Y.....	9
H3-66.....	11	MACH 5400303.....	51	QHPA14-F4A4-B.....	44	QHPA58-KIT.....	44	SSH8-63Y-BSPP.....	9
H3-66M.....	11	MACH 7980035.....	51	QHPA14-G4X4-B.....	44	SH12-62N.....	8		
H4-62.....	7	MACH 8900213.....	51	QHPA16-D6X6-B.....	43	SH12-62N-BSPP.....	8		
H4-62-BSPP.....	7	MACH 8900214.....	51	QHPA16-D6X7-B.....	43	SH12-63N.....	8		
H4-63.....	7	MACH 8900226.....	51	QHPA16-D7X7-B.....	43	SH12-63N-BSPP.....	8		
H4-63-BSPP.....	7	MACH 8900227.....	51	QHPA16-D7X8-B.....	43	SH1-62.....	8		
H4-65.....	11	MACH A.....	51	QHPA16-D7X8-B.....	43	SH1-62-BSPP.....	8		
H4-65M.....	11	MACH F08767030.....	51	QHPA16-DC.....	44	SH1-63.....	8		
H4-66.....	11	MACH2-IA-B.....	47	QHPA16-E6X6-B.....	43	SH1-63-BSPP.....	8		
H4-66M.....	11	MACH2-IA-P.....	47	QHPA16-E7X7-B.....	43	SH2-62.....	8		
H6-62.....	7	MACH4/715LB.....	50	QHPA16-E7X8-B.....	43	SH2-62-BSPP.....	8		
H6-62-BSPP.....	7	MACH4/715LBE.....	50	QHPA16-E7X8-B.....	43	SH2-63.....	8		
H6-63.....	7	MACH4/715LT.....	50	QHPA16-G4X6-B.....	44	SH2-63-BSPP.....	8		
H6-63-BSPP.....	7	MACH4/715LTE.....	50	QHPA16-G4X8-B.....	44	SH3-62.....	8		
H6-65.....	11	MACH4/715LBE.....	50	QHPA18-D7X9-B.....	43	SH3-62-BSPP.....	8		
H6-65M.....	11	MACH5/715LB.....	50	QHPA18-DC.....	44	SH3-63.....	8		
H6-66.....	11	MACH5/715LBE.....	50	QHPA18-E7X9-B.....	43	SH3-63-BSPP.....	8		
H6-66M.....	11	MACH5/715LT.....	50	QHPA18-E7X9-B.....	43	SH4-62.....	8		
H67A-28.....	11	MACH5/715LTE.....	50	QHPA53-D6X2-B.....	43	SH4-62-BSPP.....	8		
H67C-28.....	11	MACH6/715LB.....	50	QHPA53-D6X3-B.....	43	SH4-63.....	8		
		MACH6/715LBE.....	50	QHPA53-D7X3-B.....	43				
				QHPA53-D7X4-B.....	43				
				QHPA53-DP.....	44				



Parker Hannifin Corporation

About Parker Hannifin Corporation

Parker Hannifin is a leading global motion-control company dedicated to delivering premier customer service.

A Fortune 500 corporation listed on the New York Stock Exchange (PH), our components and systems comprise over 1,400 product lines that control motion in some 1,000 industrial and aerospace markets.

Parker is the only manufacturer to offer its customers a choice of hydraulic, pneumatic, and electromechanical motion-control solutions. Our Company has the largest distribution network in its field, with over 7,500 distributors serving nearly 400,000 customers worldwide.

Parker's Charter

To be a leading worldwide manufacturer of components and systems for the builders and users of durable goods.

More specifically, we will design, market and manufacture products controlling motion, flow and pressure. We will achieve profitable growth through premier customer service.

Product Information

Customers seeking product information, the location of a nearby distributor, or repair services will receive prompt attention by calling the Parker Product Information Centre. The Centre can be called toll free from France, Germany, Austria, Switzerland or the United Kingdom. You will be answered by a Parker employee in your own language. Call Freephone: 00800 27 27 5374 (00800 C PARKER).

The Aerospace Group

is a leader in the development, design, manufacture and servicing of control systems and components for aerospace and related high-technology markets, while achieving growth through premier customer service.



The Climate & Industrial Controls Group

designs, manufactures and markets system-control and fluid-handling components and systems to refrigeration, air-conditioning and industrial customers worldwide.



The Fluid Connectors Group

designs, manufactures and markets rigid and flexible connectors, and associated products used in pneumatic and fluid systems.



The Seal Group designs, manufactures and distributes industrial and commercial sealing devices and related products by providing superior quality and total customer satisfaction.



The Hydraulics Group

designs, produces and markets a full spectrum of hydraulic components and systems to builders and users of industrial and mobile machinery and equipment.



The Filtration Group

designs, manufactures and markets quality filtration and clarification products, providing customers with the best value, quality, technical support, and global availability.



The Automation Group

is a leading supplier of pneumatic and electro-mechanical components and systems to automation customers worldwide.



The Instrumentation Group

is a global leader in the design, manufacture and distribution of high-quality critical flow components for worldwide process instrumentation, ultra-high-purity, medical and analytical applications.



Fluid Connectors Europe Sales Offices

Parker Hannifin Ges. mbH

A - 2700 Wiener Neustadt
Tel: +43 (0) 26 22 23 50 10
Fax: +43 (0) 26 22 66 21 2

Parker Hannifin Corporation

AE - Abu Dhabi
Tel: +971 2 678 8587
Fax: +971 2 679 3812

Parker Hannifin Corporation

AZPAR - Techn. Repr.
for Parker Hannifin plc
AZ - 1000 Baku
Tel/Fax: +994 12 498 3966

Parker Hannifin S.A.-N.V.

B - 1400 Nivelles
Tel: +32 (0) 67 280 900
Fax: +32 (0) 67 280 999

Parker Hannifin s.r.o.

CZ - 250 67 Klecany
Tel: +420 284 083 111
Fax: +420 284 083 112

Parker Hannifin GmbH & Co. KG

D - 41564 Kaarst
Tel: +49 (0) 2131 40 16 0
Fax: +49 (0) 2131 40 16 91 99

Parker Hannifin Danmark A/S

DK - 2750 Ballerup
Tel: +45 43 56 04 00
Fax: +45 43 73 31 07

Parker Hannifin España S.A

E - 28850 Torrejón de Ardoz
(Madrid)
Tel: +34 91 675 73 00
Fax: +34 91 675 77 11

Parker Hannifin Corporation

EG - Cairo
Tel: +20 2 519 4018
Fax: +20 2 519 0605

Parker Hannifin France SAS

F - 74130 Contamine-sur-Arve
Tel: +33 (0) 4 50 25 80 25
Fax: +33 (0) 4 50 97 86 60

Parker Hannifin Oy

FI - 01520 Vantaa
Tel: +358 (0) 20 753 2500
Fax: +358 (0) 20 753 2200

Parker Hannifin plc

GB - Derby DE24 8JA
Tel: +44 (0) 1332 36 56 31
Fax: +44 (0) 1332 36 80 38

Parker Hannifin Corporation

GR - 171 21 Athens
Tel: +30 210 933 6450
Fax: +30 210 933 6451

Parker Hannifin Corporation

H - 1149 Budapest
Tel: +36 (1) 220 4155
Fax: +36 (1) 422 1525

Parker Hannifin S.p.A.

I - 20094 Corsico (MI)
Tel: +39 02 451 921
Fax: +39 02 447 9340

Parker Sales Ireland Ltd

IE - Blackrock, Co. Dublin
Tel: +353 (0) 1 293 9999
Fax: +353 (0) 1 293 9900

Parker Hannifin Corporation

Gateway Ventures Ca Ltd.
KZ - 480100 Almaty
Tel: +7 327 2 505 800
Fax: +7 327 2 505 801

Parker Hannifin A/S

N - 1402 Ski
Tel: +47 64 91 10 00
Fax: +47 64 91 10 90

Parker Hannifin B.V.

NL - 7570 AH Oldenzaal
Tel: +31 (0) 541 585 000
Fax: +31 (0) 541 585 459

Parker Hannifin Sp.z o.o.

PL - 02-235 Warszawa
Tel: +48 (0) 22 573 24 00
Fax: +48 (0) 22 573 24 03

Parker Hannifin Portugal Lda

PT - 4450-625 Leça da Palmeira
Tel: +351 22 999 7360
Fax: +351 22 996 1527

Parker Hannifin Corporation

Hidro Consulting Impex Srl
RO - 021381 Bucharest
Tel: +40 21 252 1382
Fax: +40 21 252 3381

Parker Hannifin LLC

RU - 119021 Moscow
Tel: +7 495 580 9145
Fax: +7 495 580 9146

Parker Hannifin Corporation

RU - 693000 Yuzhno-Sakhalinsk
Tel/Fax: + 7 4242 752 742

Parker Hannifin AB

SE - 163 08 Spånga
Tel: +46 (0) 8 5979 5000
Fax: +46 (0) 8 5979 5110

Parker Hannifin Corporation

SI - 8000 Novo Mesto
Tel: +386 (7) 337 6650
Fax: +386 (7) 337 6651

Parker Hannifin Corporation

TR - 34067 Merter/Istanbul
Tel: +90 212 482 91 06/07
Fax: +90 212 482 91 10

Parker Hannifin Corporation

UA - 01004 Kiev
Tel: +380 (0) 44 494 2731
Fax: +380 (0) 44 494 2730

Parker Hannifin Africa

ZA - Kempton Park
Tel: +27 11 961 0700
Fax: +27 11 392 7213

www.parker.com/euro_bpd

For further information on other Parker Products, call the European Product Information Centre (EPIC) free of charge on 00800 27 27 5374.



Catalogue 3800-DS/UK
© 2004 Parker Hannifin
Plantijn Casparie 10/2006