



# Axial Piston Pump

Series PV  
Design 42/43  
Variable Displacement

aerospace  
climate control  
electromechanical  
filtration  
fluid & gas handling  
**hydraulics**  
pneumatics  
process control  
sealing & shielding



ENGINEERING YOUR SUCCESS.

<b>Contents</b>	<b>Page</b>
Introduction.....	3
Ordering Code Preferred Program .....	4
Noise Levels .....	8
Efficiency and Case Drain Flows.....	9
Dimensions.....	11
Mounting kits .....	17
 <b>Pump combinations</b>	
Thru Drive, Shaft Load Limitations.....	18
 <b>Compensators</b>	
Compensators Dimensions.....	19
Pressure Compensators .....	23
Load-Sensing Compensators.....	24
Power Compensators.....	25
Power Compensators, Diagrams.....	26
Electronic Module PQDXXA (digital).....	28
General Installation Information .....	29
Accessories Compensator .....	30

**Technical Features**

- Low noise level
- Fast response
- Service-friendly
- High self-priming speed
- Compact design
- Thru drive for 100% nominal torque

**With thru drive for single and multiple pumps**

Swash plate type for open circuit

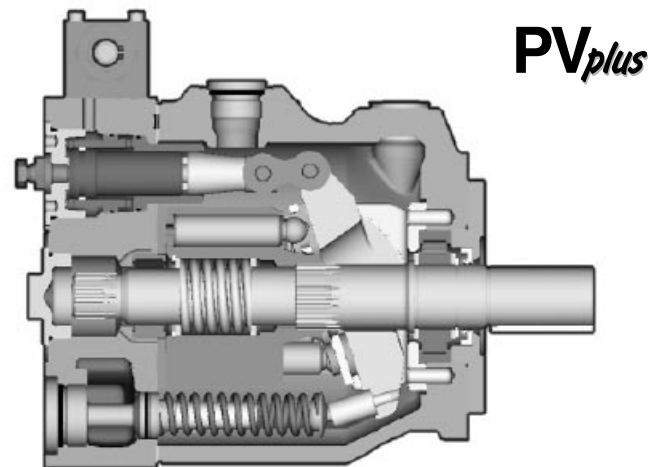

**Technical Data**

Size		PV063	PV080	PV092	PV140	PV180	PV270
Max. Displacement	[cm <sup>3</sup> /rev.]	63	80	92	140	180	270
Output flow at 1500 min <sup>-1</sup>	[l/min]	94.5	120	138	210	270	405
Nominal pressure p <sub>N</sub>	[bar]	350	350	350	350	350	350
Max. pressure p <sub>max</sub> <sup>1)</sup>	[bar]	420	420	420	420	420	420
Max. Case drain pressure	[bar]	0.5	0.5	0.5	0.5	0.5	0.5
Min. Inlet pressure, abs.	[bar]	0.8	0.8	0.8	0.8	0.8	0.8
Max. Inlet pressure	[bar]	16	16	16	16	16	16
Input power at 1500 min <sup>-1</sup> and 350 bar	[kW]	61.5	78	89.5	136	175	263
Max speed <sup>2)</sup>	[min <sup>-1</sup> ]	2800	2500	2300	2400	2200	1800
Moment of inertia	[kgm <sup>2</sup> ]	0.018	0.018	0.018	0.030	0.030	0.098
Weight	[kg]	60	60	60	90	90	172

1) Maximum 20% of the working cycle.

2) The maximum speed ratings are shown for an inlet pressure of 1 bar (absolute) and for a fluid viscosity of  $\nu = 30 \text{ mm}^2/\text{s}$

**General Information**

Premium quality hydraulic mineral fluid are recommended, like HLP oils to DIN 51522, part 2, Bruggen- value has to be 30 N/mm<sup>2</sup> minimum for general application and 50 N/mm<sup>2</sup> for heavily loaded hydraulic equipment and fast cycling machines and/or high dynamic loads, measured in accordance with DIN 51 347-2, see also Document HY30-3248/UK Parker Hydraulic- Fluids.

**Viscosity**

The normal operating viscosity should range between 16 and 100 mm<sup>2</sup>/s (cSt). Max. start-up viscosity is 800 mm<sup>2</sup>/s (cSt).

**Seals**

NBR seals are used for operation with hydraulic fluids based on mineral oil. For synthetic fluids, such as phosphoric acid esters, Fluorocarbon seal are required.

**Filtration**

For maximum pump and system component functionality and life, the system should be protected from contamination by effective filtration.

Fluid cleanliness should be in accordance with ISO classification ISO 4406:1999. The quality of filter elements should be in accordance with ISO standards.

Minimum requirement for filtration rate  $x$  (mm);

General hydraulic systems for satisfactory operation: Class 20/18/15, according to ISO 4406:1999

Hydraulic systems with maximised component life and functionality:

Class 18/16/13, according to ISO 4406:1999

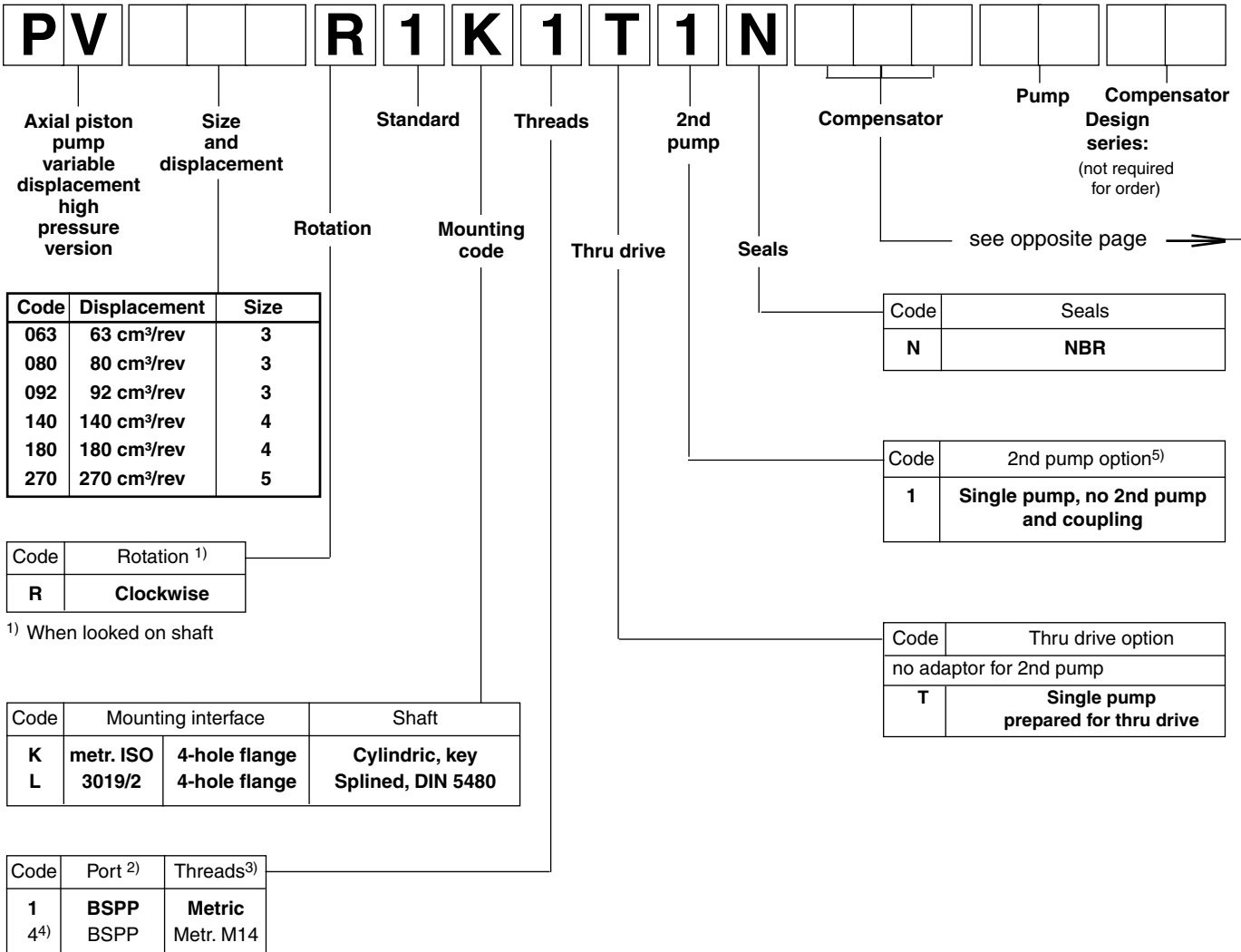

<sup>1)</sup> When looked on shaft

<sup>2)</sup> Drain, gauge and flushing ports

<sup>3)</sup> All mounting and connecting threads

<sup>4)</sup> For PV063-PV180 only: pressure port 1 1/4" with 4 x M14 instead of 4 x M12

Mounting kits for flexible mounting of multiple pumps, see page 17.

Standard Pressure Compensator			
Code		Compensator options	
0	0	1	Without compensator
F	D	S	10 - 140 bar, spindle + lock nut
F	H	S	40 - 210 bar, spindle + lock nut
F	W	S	70 - 350 bar, spindle + lock nut
Remote Compensator options			
F	R		Remote pressure compensator
F	F		Load-Sensing compensator
Variations for Remote Compensator			
		C	External pressure pilot <sup>8)</sup>
		1	NG6/D03 interface top side
		P	Pilot valve PVAC1P* mounted

Power compensator						
Code		Displacement			Compensator option	
		063 092	140	180	270	
						Nom. power [kW] at 1500 min <sup>-1</sup>
						Nom. torque- [Nm]
G						11
H						15
K						18.5
M						22
S						30
T						37
U						45
W						55
Y						75
Z						90
2						110
3						132
Function						
	L					Power compensator
	C					Power compensator and load-sensing
Variation						
		A				NG6 interface top side
		B				No pressure compensation
		C				Adjustable pressure compensation

Code		Compensator style	
electro hydraulic control			
F	P	V	closed loop displacement control only, no pressure compensation
U	P		closed loop proportional displacement control with pressure compensation
compensator version			
		R	balanced pressure control, NG6 interface
		K	version UPR, with proportional pilot valve type PVACRE..35 mounted
		M	version UPK, with pressure sensor for closed loop pressure and power control

**Note:**

**Compensator differential  $\Delta p$**  is factory pre-set to:  
 remote compensators, power control      **15 ± 1 bar**  
 load sensing comp. (not power control)      **10 ± 1 bar**



axial piston pump variable displacement high pressure version

rotation

variation

mounting interface

threads code

thru drive code

coupling code

seals

compensator

see next page

Code	Displacement	Size
063	63 cm <sup>3</sup> /rev	3
080	80 cm <sup>3</sup> /rev	3
092	92 cm <sup>3</sup> /rev	3
140	140 cm <sup>3</sup> /rev	4
180	180 cm <sup>3</sup> /rev	4
270	270 cm <sup>3</sup> /rev	5

Code	Rotation <sup>1)</sup>
R	Clockwise
L	Counter clockwise

<sup>1)</sup> When looked on shaft

Code	Variation
1	Standard
9	special adjustment <sup>2)</sup>

<sup>2)</sup> requires Kxxxx number

Code	Mounting interface	Shaft
D	SAE	Cylindric, key
E	ISO	Splined, SAE
F <sup>3)</sup>	3019/1	Cylindric, key
G <sup>3)</sup>	3019/1	Splined, SAE
K	metr. ISO	Cylindric, key
L	3019/2	Splined, DIN 5480

<sup>3)</sup> Codes F and G only for PV140/180

Code	Port <sup>4)</sup>	Threads <sup>5)</sup>
1	BSPP	metric
3	UNF	UNC
4 <sup>6)</sup>	BSPP	metr. M14
7	ISO 6149	UNC
8	ISO 6149	metrisch

<sup>4)</sup> Drain, gauge and flushing ports

<sup>5)</sup> All mounting and connecting threads

<sup>6)</sup> For PV063, PV080-PV180 only: pressure port 1 1/4" with 4 x M14 instead of 4 x M12

Code	Seals
N	NBR
V	FPM
W	NBR with PTFE shaft seal
P	FPM with PTFE shaft seal

Code	Coupling for thru drive
1	Single pump, no coupling
2	PV140 or PV180 mounted
3	PV pump mounted
4	Gear pump mounted

Option 2, 3 and 4 not available for single pump. Second pump must be specified with full model code.

Code	Thru drive option	
No adaptor for 2nd pump		
T	Single pump prepared for thru drive	
with adaptor for 2nd pump		
as single part <sup>10)</sup>		
A	SAE A, Ø 82.55 mm	MK-PVBGxAMN
B	SAE B, Ø 101.6 mm	MK-PVBGxBMN
C <sup>7)</sup>	SAE C, Ø 127 mm	MK-PVBGxCMN
D <sup>7)</sup>	SAE D, Ø 152,4 mm	MK-PVBGxDMN
E <sup>8)</sup>	SAE E, Ø 165,1 mm	MK-PVBGxEMN
G <sup>9)</sup>	metric, Ø 63 mm	MK-PVBGxGMN
H	metric, Ø 80 mm	MK-PVBGxHMN
J	metric, Ø 100 mm	MK-PVBGxJMN
K <sup>7)</sup>	metric, Ø 125 mm	MK-PVBGxKMN
L <sup>7)</sup>	metric, Ø 160 mm	MK-PVBGxLMN
M <sup>8)</sup>	metric, Ø 200 mm	MK-PVBGxMMN

See dimensions for details

<sup>7)</sup> only for PV063 and larger

<sup>8)</sup> only for PV270

<sup>9)</sup> only for PV063 - PV092

<sup>10)</sup> x= frame size, see page 17.

Mounting kits for flexible mounting of multiple pumps, see page 17.

Standard Pressure Compensator		
Code	Compensator options	
0 0 1	No compensator	
1 0 0	With cover plate, no control function	
F D S	10 - 140 bar, Spindle + lock nut	
F H S	40 - 210 bar, Spindle + lock nut	
F W S	70 - 350 bar, Spindle + lock nut	
Remote compensator options		
F R	Remote pressure compensator	
F S	Variation R, for quick unload valve	
F F	Load-Sensing compensator	
F T	Two valve load-sensing compensator	
Compensator variation		
C	External pressure pilot <sup>14)</sup>	
1	NG6 interface top side for pilot valves	
2	Like 1 but with ext. pilot port <sup>16)</sup>	
P	Pilot valve PVAC1P* mounted	
K	Prop.-pilot valve type PVACRE..35 mounted	
L	Pilot valve with DIN lock mounted	
Z	Accessory mounted <sup>15)</sup>	

Horse power compensator								
Code	Displacement				Compensator option		Nom. torque [Nm]	
	063	140	180	270	Nominal HP. [kW] at 1500 rpm			
G						11	71	
H						15	97	
K						18,5	120	
M						22	142	
S						30	195	
T						37	240	
U						45	290	
W						55	355	
Y						75	485	
Z						90	585	
2						110	715	
3						132	850	
Function								
L						Horse power compensator		
C						Horse power compensator and Load Sensing		
Compensator variation								
	A					NG 6 interface top side		
	B					No pressure compensation		
	C					Adjustable pressure compensation		
	K					Prop.-pilot valve type PVACRE..35 mounted		
	Z					Accessories mounted <sup>15)</sup>		

Electrohydraulic compensator		
Code	Compensator option	
	Pilot pressure supply	
F P V	closed loop displacement control only, no pressure compensation	
Function		
U P	Proportionalhubvolumenregelung	
Variation		
	R	balanced pressure control, NG6 interface
	K	version UPR, with proportional pilot valve type PVACRE..35 mounted
	M	version UPK, with pressure sensor for closed loop pressure and power control
	Z	Version R, accessories mounted <sup>15)</sup>

**Note**

Compensator differential  $\Delta p$  is to be adjusted:

remote compensators, power control **15 ± 1 bar**  
(Codes FR\*, FT\*, \*L\*, \*C\*, UPR, UPD, UPZ, UPG)

load sensing comp. (not power control) **10 ± 1 bar**  
(Codes FF\*)

<sup>14)</sup> Not for two-valve-compensator

<sup>15)</sup> Accessories not included, please specify on order with full model code.

<sup>16)</sup> Only Codes \*FR\* and \*FT\*

**PV063 - PV092**

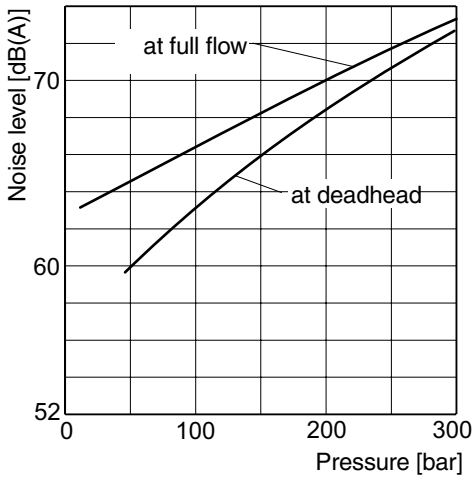

**PV180**

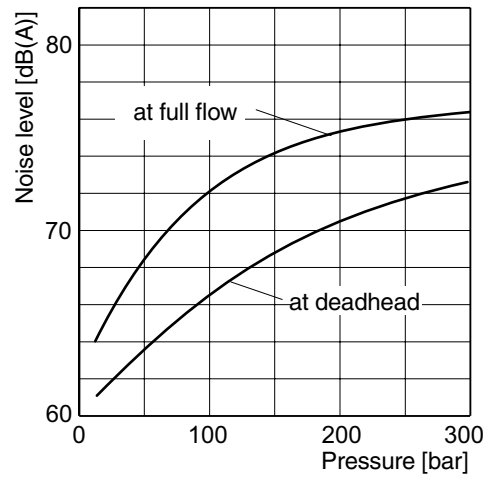

**PV140**

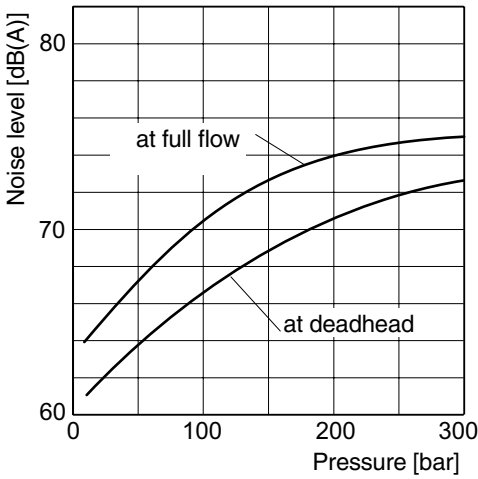

**PV270**

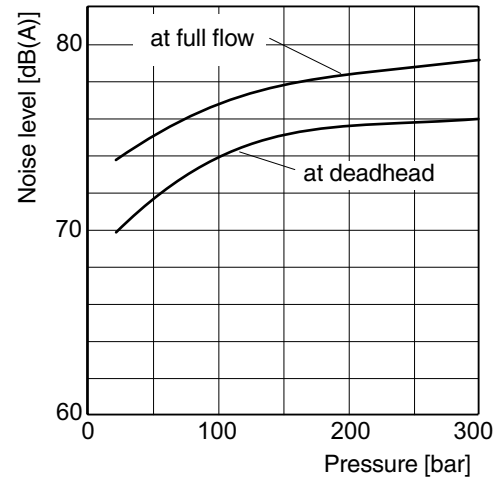

Typical sound level for single pumps, measured in anechoic chamber according to DIN 45 635, part 1 and 26. Microphone distance 1m; speed: n = 1500 rpm.

All data measured with mineral oil viscosity 30 mm<sup>2</sup>/s (cSt) at 50°C.



Efficiency, power consumption

PV063

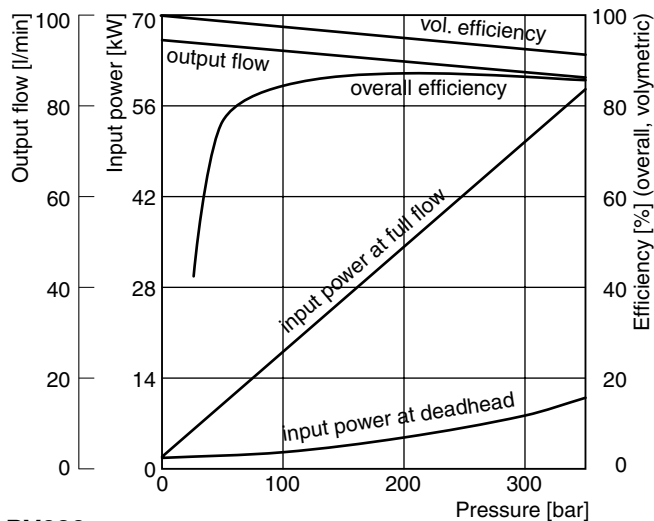

PV080

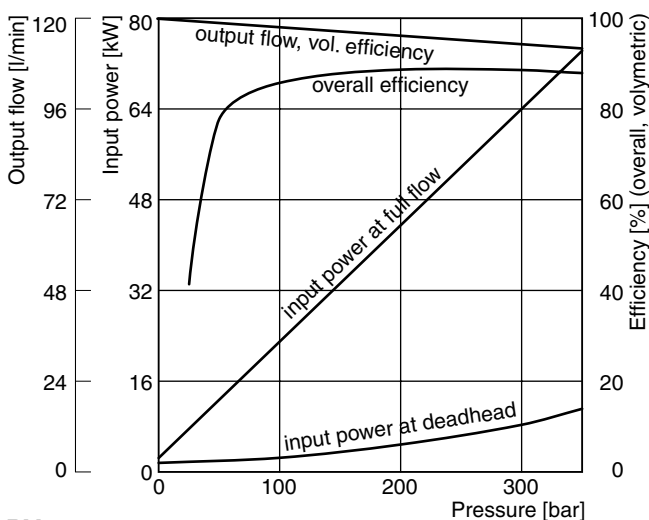

PV092

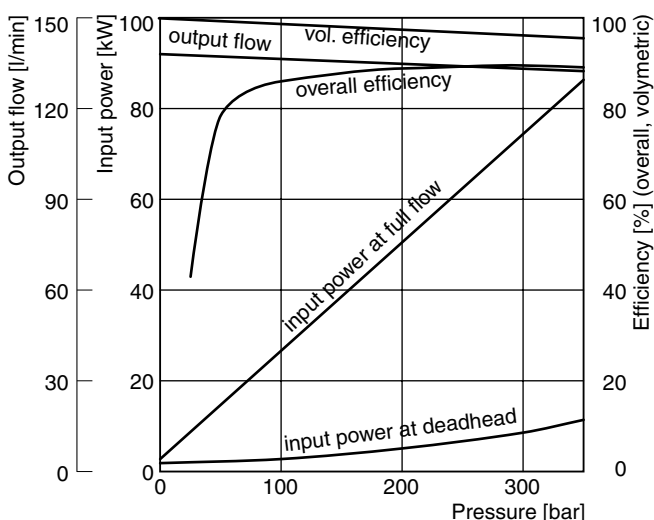

Efficiency and case drain flows PV063, PV080, PV092

The efficiency and power graphs are measured at an input speed of  $n = 1500$  rpm, a temperature of  $50\text{ }^{\circ}\text{C}$  and a fluid viscosity of  $30\text{ mm}^2/\text{s}$ .

Case drain flow and compensator control flow leave via the drain port of the pump. To the values shown are to be added 1 to 1.2 l/min, if at pilot operated compensators (codes FR\*, FF\*, FT\*, power compensator and p-Q-control) the control flow of the pressure pilot valve also goes through the pump.

**Please note:** The values shown below are only valid for static operation. Under dynamic conditions and at rapid compensation of the pump the volume displaced by the servo piston also leaves the case drain port. This dynamic control flow can reach up to 80 l/min! Therefore the case drain line is to lead to the reservoir at full size and without restrictions as short and direct as possible.

Case drain flows PV063-092

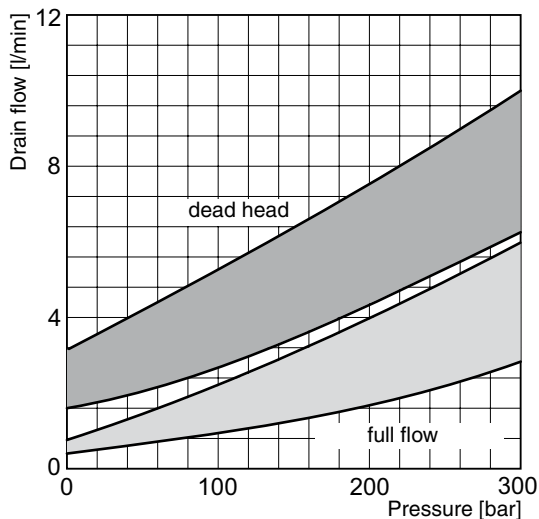

**Efficiency, power consumption**

**PV140**

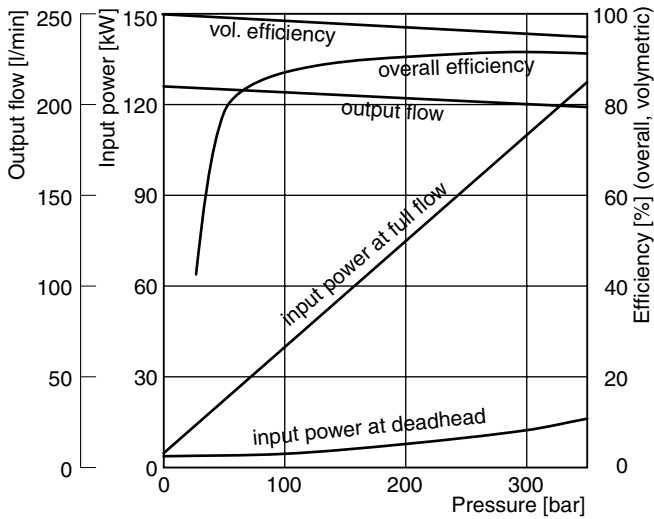

**Efficiency and case drain flows PV140, PV180, PV270**

The efficiency and power graphs are measured at an input speed of  $n = 1500$  rpm, a temperature of  $50\text{ }^\circ\text{C}$  and a fluid viscosity of  $30\text{ mm}^2/\text{s}$ .

Case drain flow and compensator control flow leave via the drain port of the pump. To the values shown are to be added 1 to 1.2 l/min, if at pilot operated compensators (codes FR\*, FF\*, FT\*, power compensator and p-Q-control) the control flow of the pressure pilot valve also goes through the pump.

**Please note:** The values shown below are only valid for static operation. Under dynamic conditions and at rapid compensation of the pump the volume displaced by the servo piston also leaves the case drain port. This dynamic control flow can reach up to 120 l/min! Therefore the case drain line is to lead to the reservoir at full size and without restrictions as short and direct as possible.

**PV180**

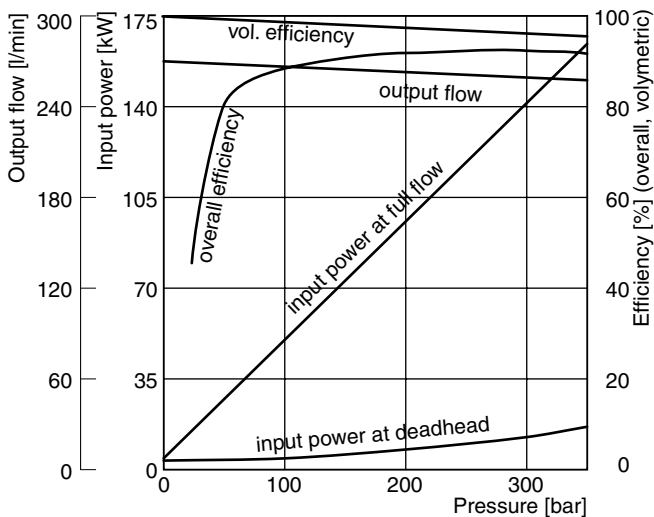

**Case drain flows PV140-180**

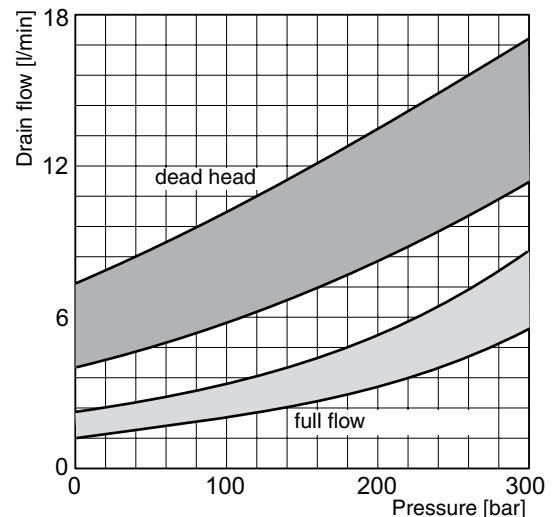

**PV270**

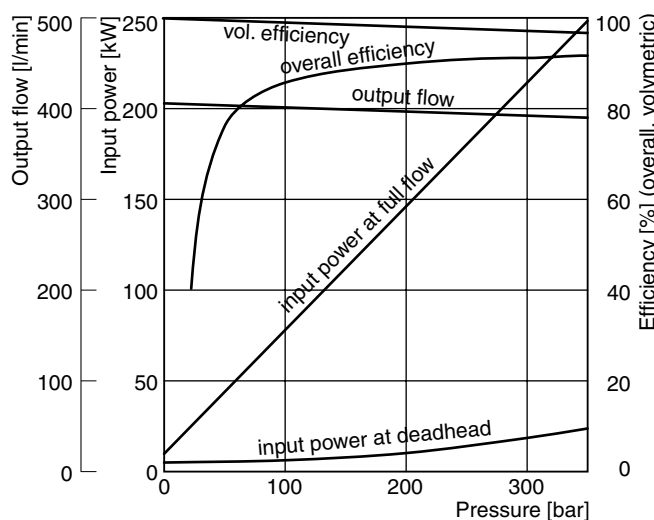

**Case drain flows PV270**

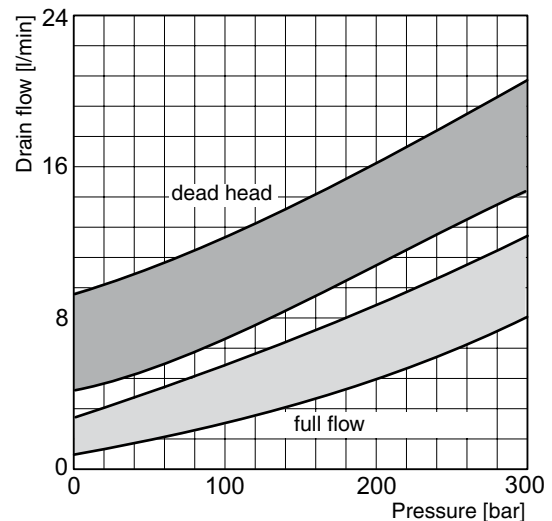

**PV063 - 092, metric version**

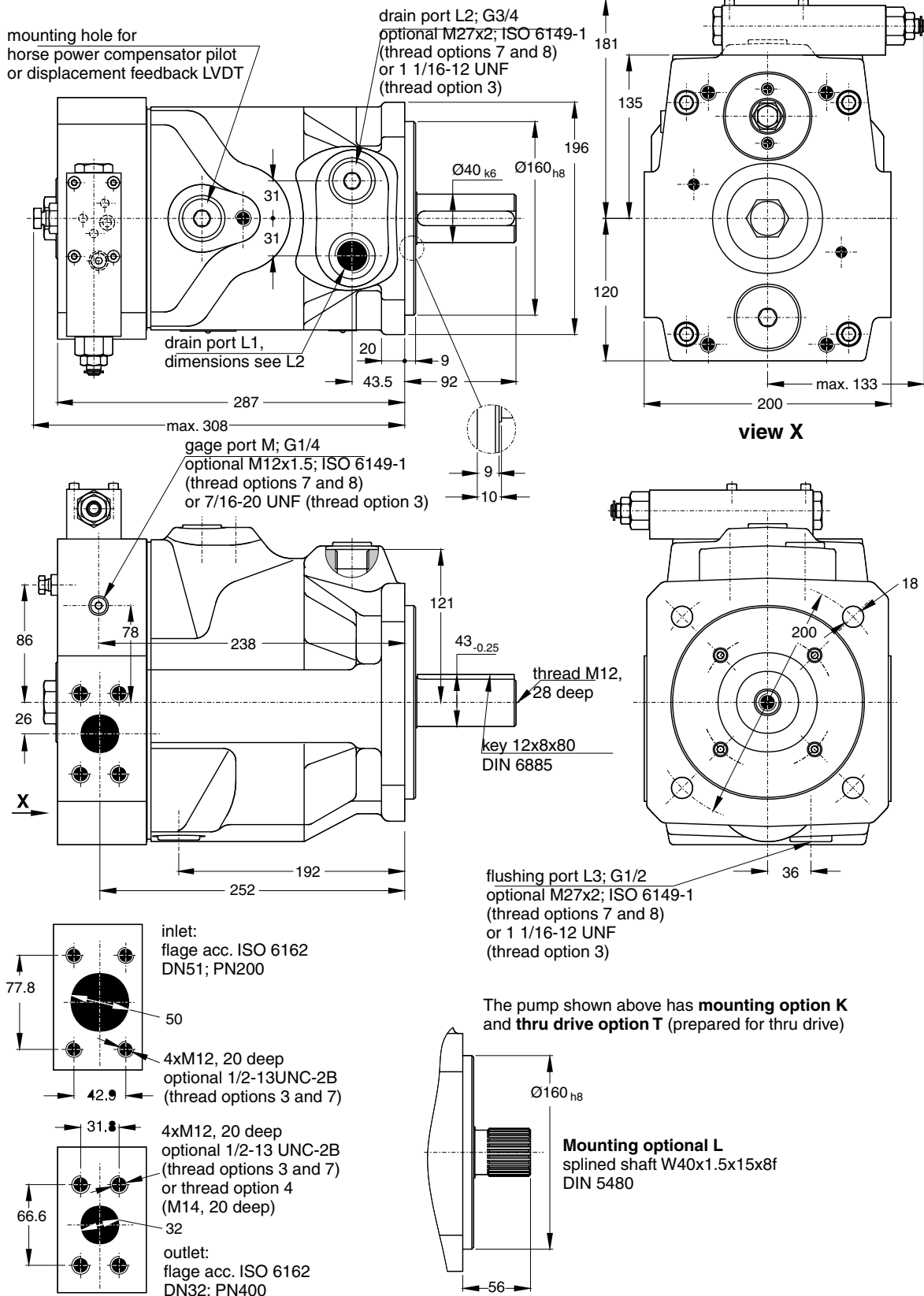

Shown is a clockwise rotating pump with standard pressure compensator. Counter clockwise rotating pumps have inlet, outlet and gauge port reversed.

**PV063 - 092, SAE version**

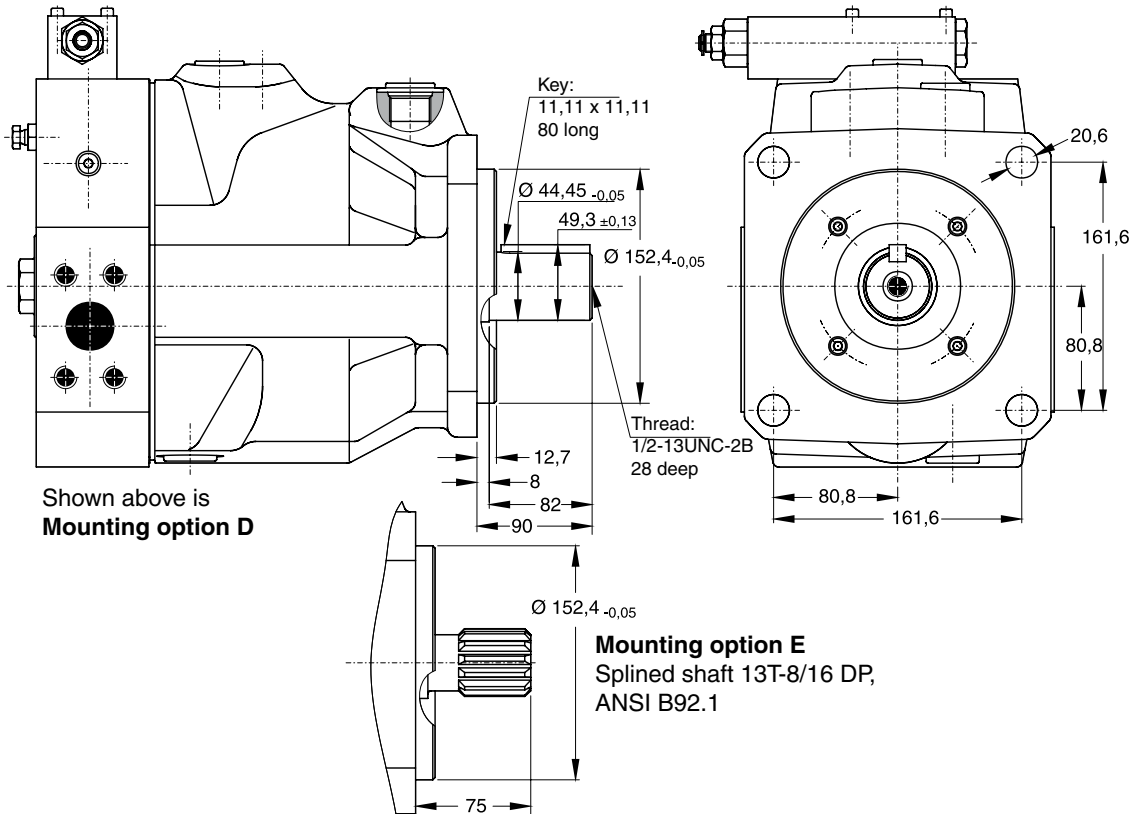

**Variation with thru drive**

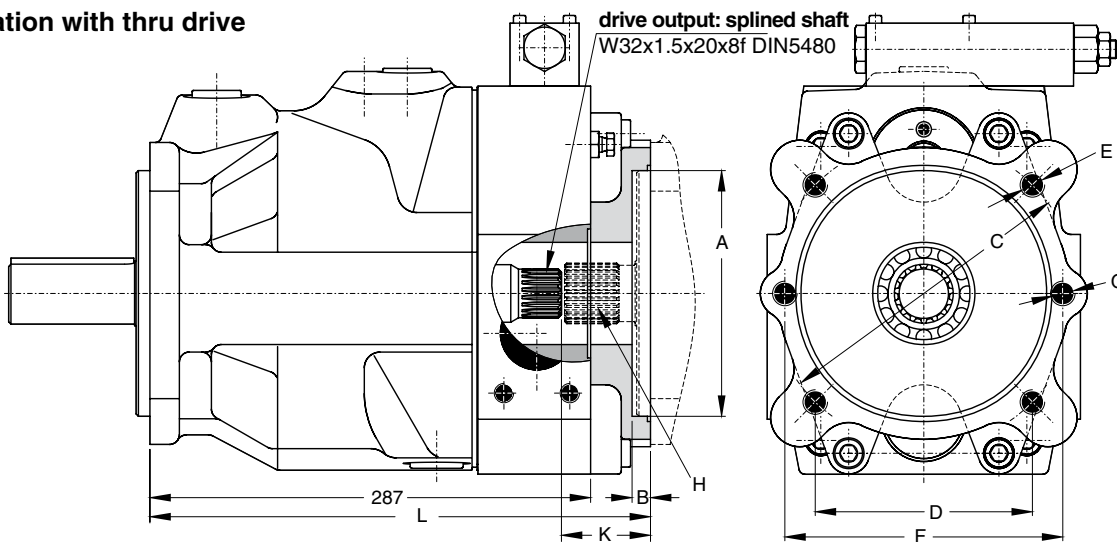

**Thru drive adaptors are available with the following dimensions**

Drawing Dimension	A	B	C	D	E	F	G	Remark
<b>Thru drive option</b>								
A	82,55	10	-	-	-	100	M8	SAE A 2-Bolt
B	101,6	12	127	89,8	M12	146	M12	SAE B 2/4-Bolt
C	127	14	161,6	114,5	M12	181	M16	SAE C 2/4-Bolt
D	152,4	14	228,5	161,6	M16	-	-	SAE D 4-Bolt
G	63	10	85	60,1	M8	100	M8	2/4-Bolt
H	80	10	103	72,8	M8	109	M10	2/4-Bolt
J	100	12	125	88,4	M10	140	M12	2/4-Bolt
K	125	12	160	113,1	M12	180	M16	2/4-Bolt
L	160	12	200	141,4	M16	-	-	4-Bolt

**PV140 - 180, metric version**

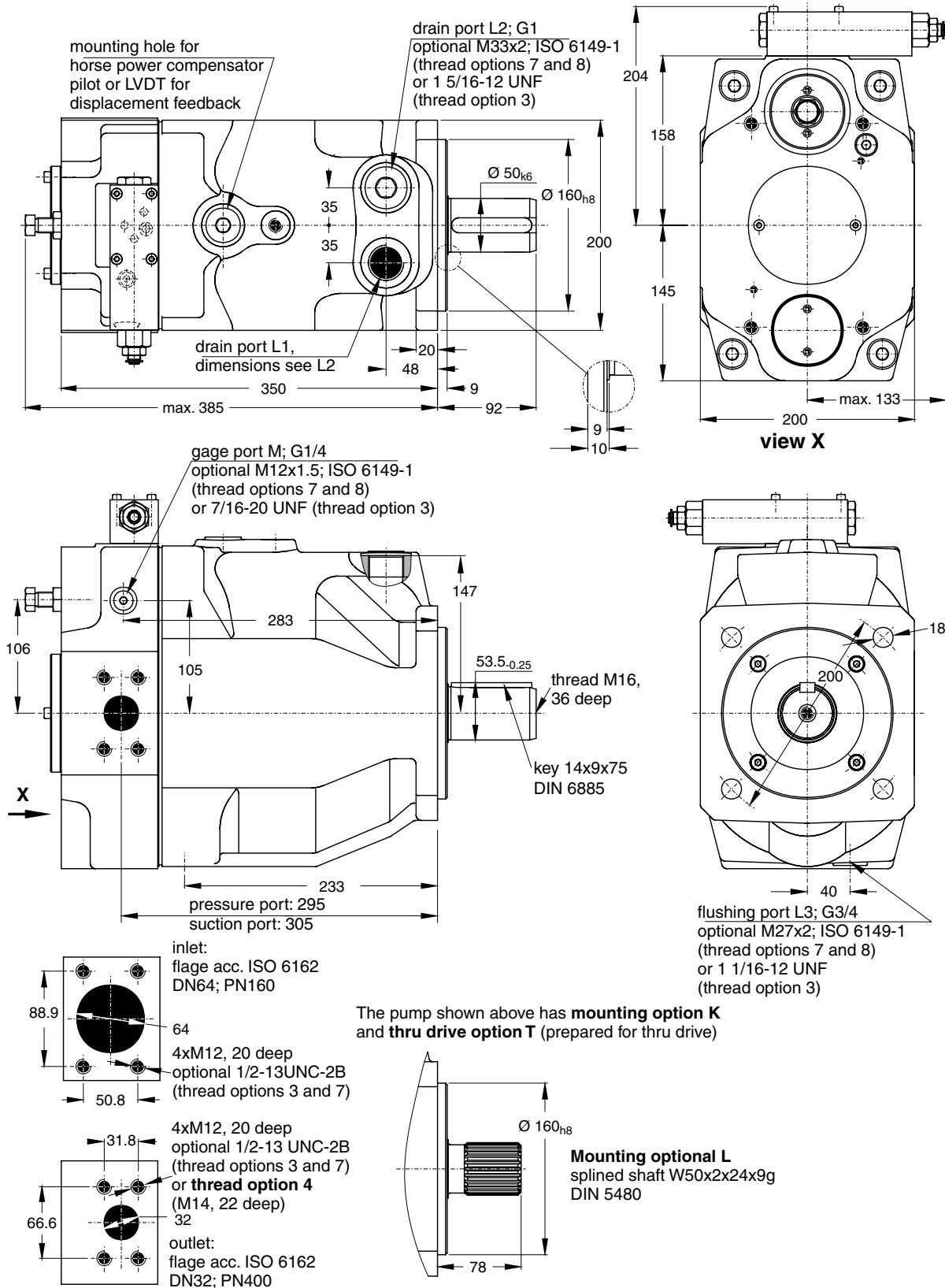

Shown is a clockwise rotating pump with standard pressure compensator. Counter clockwise rotating pumps have inlet, outlet and gauge port reversed.

**PV140 - 180, SAE version**

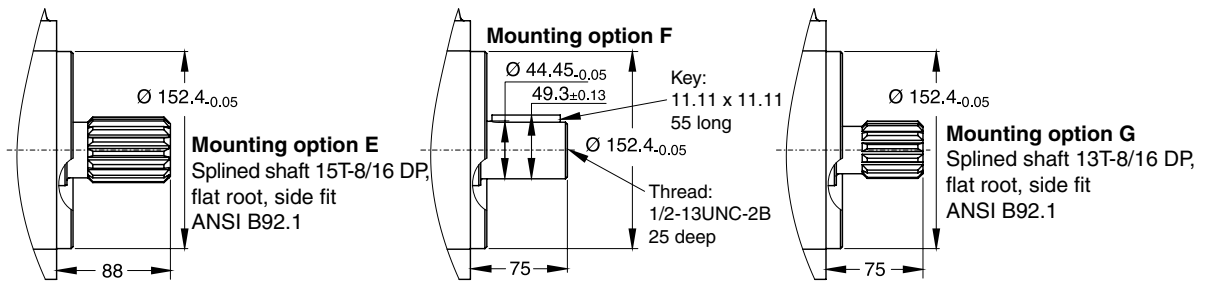
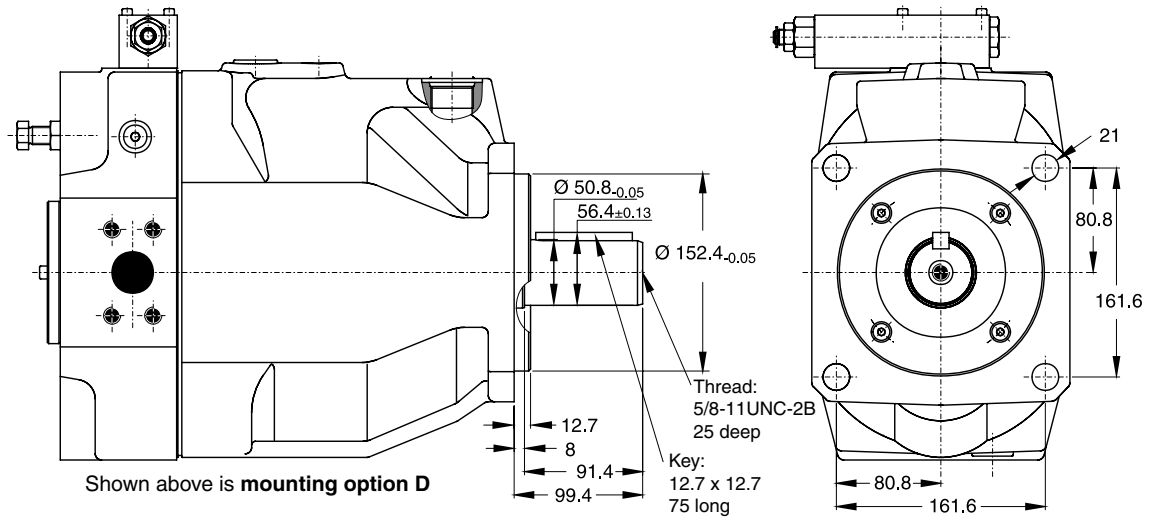

**Variation with thru drive**

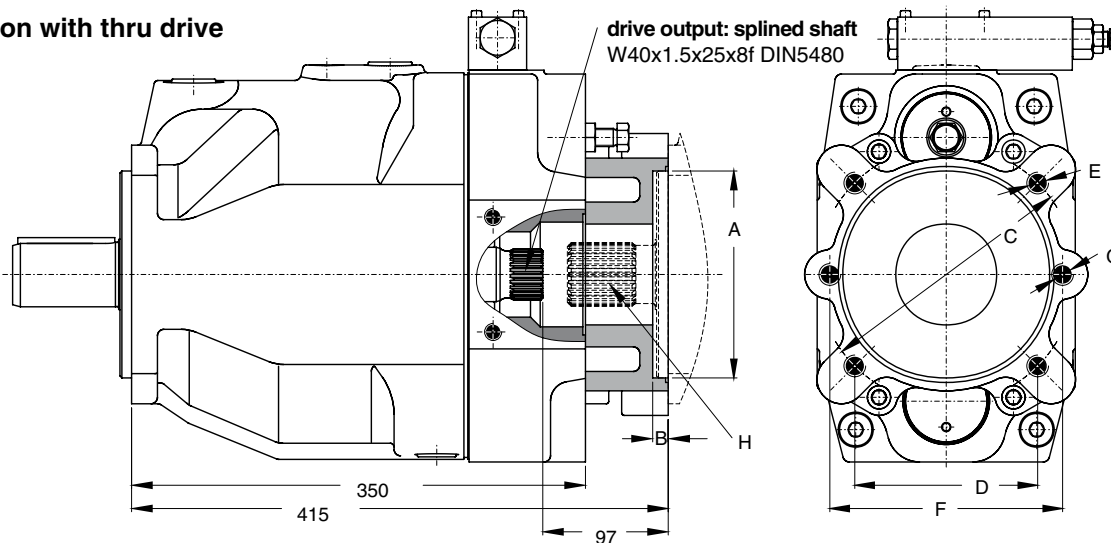

**Thru drive adaptors are available with the following dimensions**

Drawing Dimension	A	B	C	D	E	F	G	Remark
<b>Thru drive option</b>								
A	82,55	10	-	-	-	106	M10	SAE A 2-Bolt
B	101,6	12	127	89,8	M12	146	M12	SAE B 2/4-Bolt
C	127	14	161,6	114,5	M12	181	M16	SAE C 2/4-Bolt
D	152,4	14	228,5	161,6	M16	-	-	SAE D 4-Bolt
H	80	10	103	72,8	M8	109	M10	2/4-Bolt
J	100	12	125	88,4	M10	140	M12	2/4-Bolt
K	125	12	160	113,1	M12	180	M16	2/4-Bolt
L	160	12	200	141,4	M16	-	-	4-Bolt

**PV 270, metric version**

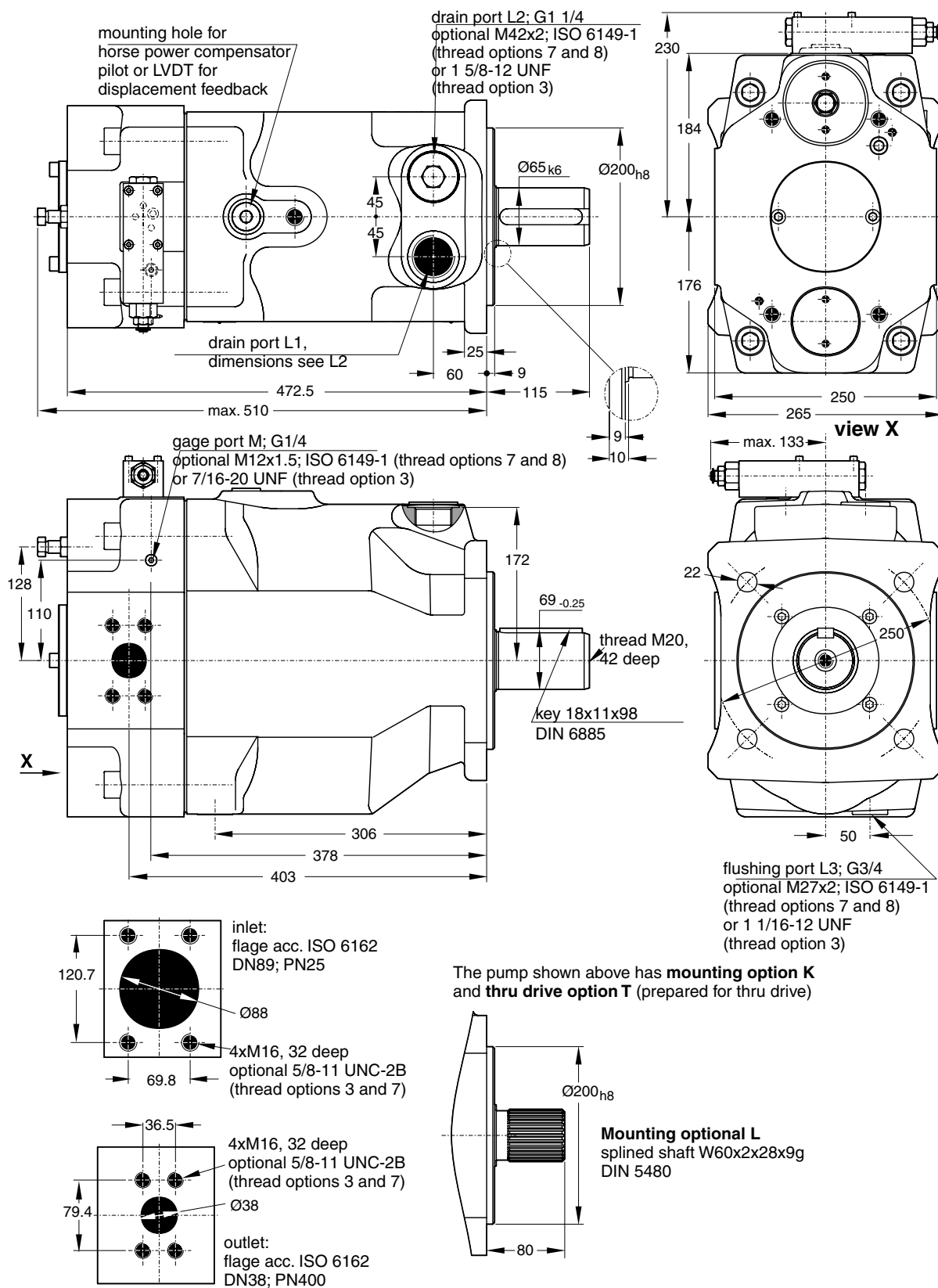

Shown is a clockwise rotating pump with standard pressure compensator.  
 Counter clockwise rotating pumps have inlet, outlet and gauge port reversed.

**PV270, SAE version**

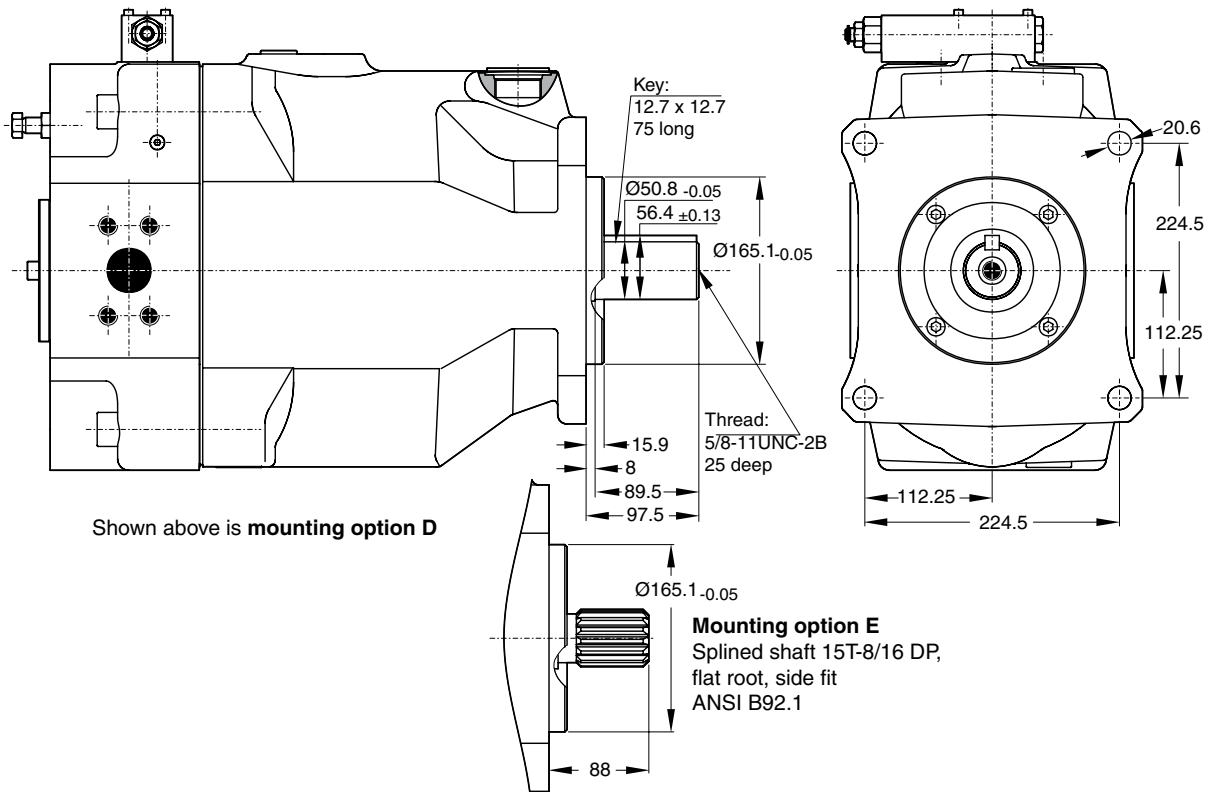

**Variation with thru drive**

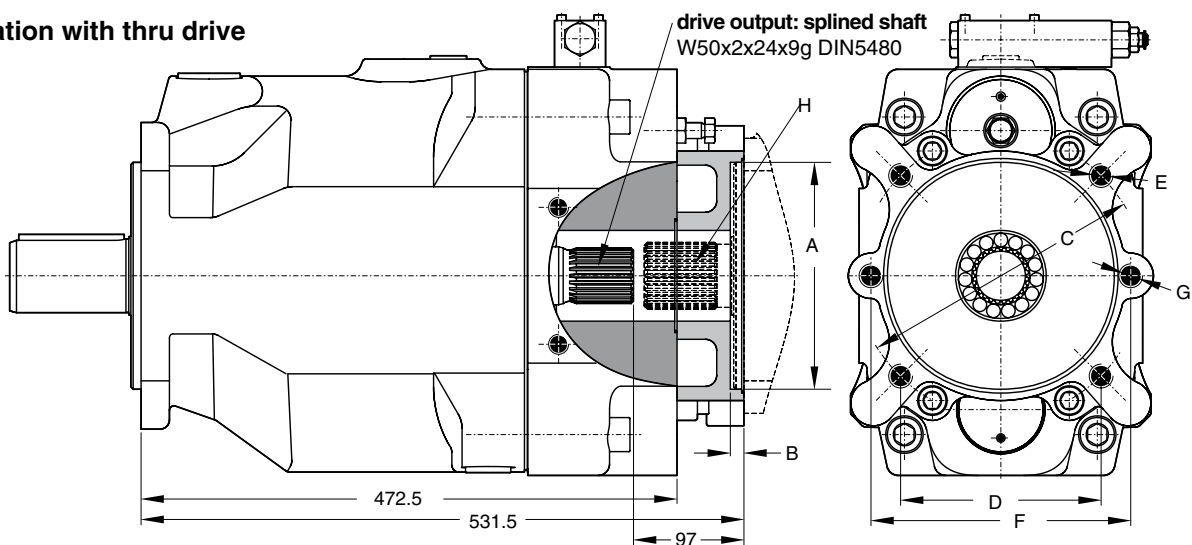

**Thru drive adaptors are available with the following dimensions**

Drawing Dimension	A	B	C	D	E	F	G	Remark
<b>Thru drive option</b>								
A	82,55	8	-	-	-	106	M10	SAE A 2-Bolt
B	101,6	11	127	89,8	M12	146	M12	SAE B 2/4-Bolt
C	127	13,5	161,6	114,5	M12	181	M16	SAE C 2/4-Bolt
D	152,4	13,5	228,5	161,6	M16	229	M20	SAE D 2/4-Bolt
E	165,1	17	317,5	224,5	M20	-	-	SAE E 4-Bolt
H	80	8,5	103	72,8	M8	109	M10	2/4-Bolt
J	100	10,5	125	88,4	M10	140	M12	2/4-Bolt
K	125	10,5	160	113,1	M12	180	M16	2/4-Bolt
L	160	13,5	200	141,4	M16	224	M20	2/4-Bolt
M	200	13,5	250	176,8	M20	-	-	4-Bolt



**Mounting kits for multiple pumps, for second pump option**

MK - PV    BG                    

Mounting kit    Axial piston pump series PV    Size    Second pump    Thread    Seals

Code	Pump size	Code	Second pump, SAE	Code	Seals
1	Pump size 1: PV016 - PV023	T	Prepared for thru drive option (plugged)	N	NBR
2	Pump size 2: PV032 - PV046	Y	SAE AA, diameter 50.8 mm	V	FPM
3	Pump size 3: PV063 - PV092	A	SAE A, diameter 82.55 mm		
4	Pump size 4: PV140 - PV180	B	SAE B, diameter 101.6 mm		
5	Pump size 5: PV270	C	SAE C, diameter 127 mm		
		D	SAE D, diameter 152.4 mm		
		E	SAE E, diameter 165.1 mm		
		Second pump, metric			
		G	Diameter 63 mm		
		H	Diameter 80 mm		
		J	Diameter 100 mm		
		K	Diameter 125 mm		
		L	Diameter 160 mm		
		M	Diameter 200 mm		

Code	Thread
M	Metric
S	SAE

Kit contains positions 30, 69, 84, 85 and 87, see drawing below.

**Mounting kits for multiple pumps, couplings**

MK - PV    BG         K     

Mounting kit    Axial piston pump series PV    Size    Coupling

Code	Pump size	Code	Coupling for metric, splined shaft DIN 5480
1	Pump size 1: PV016 - PV023	01	N25 x 1.5 x 15
2	Pump size 2: PV032 - PV046	02	N32 x 1.5 x 20
3	Pump size 3: PV063 - PV092	03	N40 x 1.5 x 25
4	Pump size 4: PV140 - PV180	04	N50 x 2 x 24
5	Pump size 5: PV270	05	N60 x 2 x 28
			Coupling for SAE splined shaft flat root, side fit
		11	SAE A, 9T 16/32
		12	SAE-, 11T 16/32
		13	SAE B, 13T 16/32
		14	SAE B-B, 15T 16/32
		15	SAE C, 14T 12/24
		16	SAE C-C, 17T 12/24
		17	SAE D+E, 13T 8/16
		18	SAE F, 15T 8/16
			Coupling + adaptor for keyed shaft
		20	Diameter 12 mm
		21	Diameter 16 mm
		22	Diameter 18 mm

Kit contains positions 91 (and 92 for keyed shaft).

**Max. transferable torque in [Nm] for different shafts options**

Shaft code	PV063-092	PV140-180	PV270
D	1320	2000	2000
E	1218	2680	2680
F	--	1320	--
G	--	1640	--
K	1150	1900	2850
L	1400	2650	3980
Max. torque transmission cap. for rear mounted pump	560	1100	1650

**Important notice**

The max. allowable torque of the individual shaft must not be exceeded. For 2-pump combinations there is no problem because PV series offers 100% thru torque. For 3-pump combinations (and more) the limit torque could be reached or exceeded.

Therefore it is necessary to calculate the torque factor and compare it with the allowed torque limit factor in the table.

**Required:** calculated torque factor  
 < torque limit factor

To make the necessary calculations easier and more user friendly it is not required to calculate actual torque requirements in Nm and compare them with the shaft limitations. The table on the right shows limit factors that include material specification, safety factors and conversion factors.

The **total torque factor** is represented by the sum of the individual torque factors of all pumps in the complete pump combination.

**Total torque factor of the combination**  
 = sum of individual torque factors of all pumps

The **torque factor of each individual pump** is calculated by multiplying the max. operating pressure p of the pump (in bar) with the max. displacement Vg of the pump (in cm<sup>3</sup>/rev).

**Torque factor of any pump**  
 = p x Vg

Pump	Shaft	Torque limit factor
PV063-092	D	77280
	E	72450
	K	67620
	L	83720
PV140-180	D	118400
	E	158760
	F	78750
	G	97650
	L	157500
PV270	D	119000
	E	159700
	K	170100
	L	236250

**Dimensions standard pressure compensator, code ...FDS, ...FHS, ...FWS**

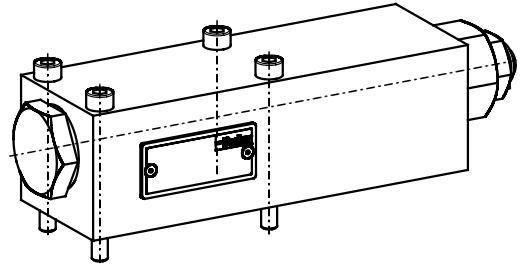
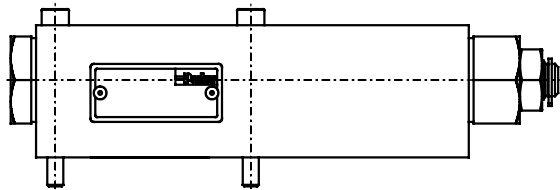
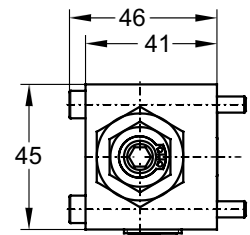
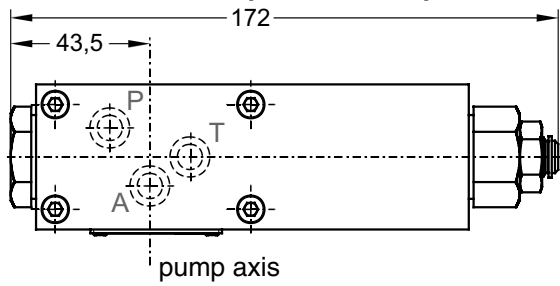

**Dimensions remote pressure and load sensing compensator, codes ...FRC, ...FFC**

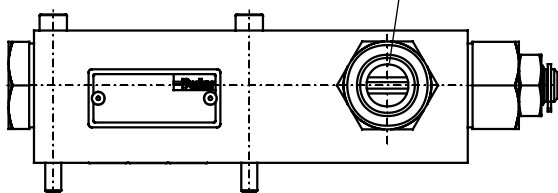
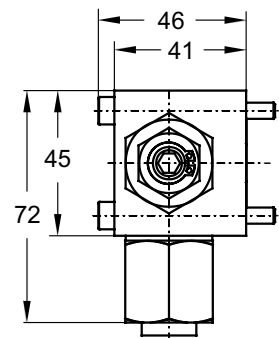
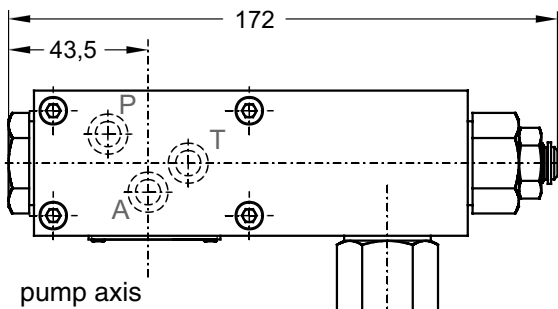

remote control port  $p_P$  (code ...FRC)  
 resp. LS port  $p_F$  (code ...FFC)

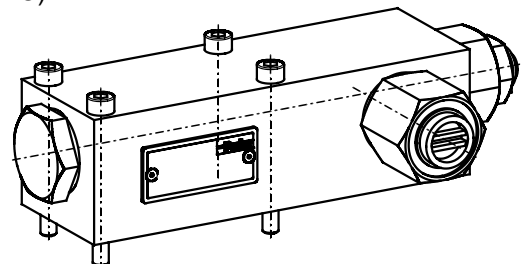

**Dimensions horse power control cartridge and displacement sensor**

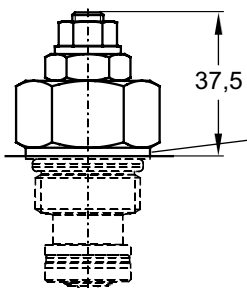

pump body (case)

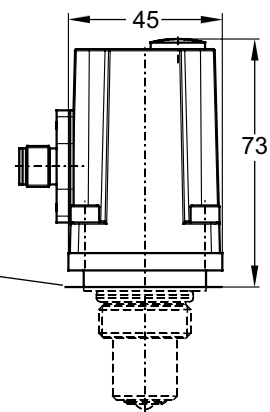

**Dimensions compensator with NG6-interface for pilot valves, codes ...FR1, ...FR2, ...FF1**

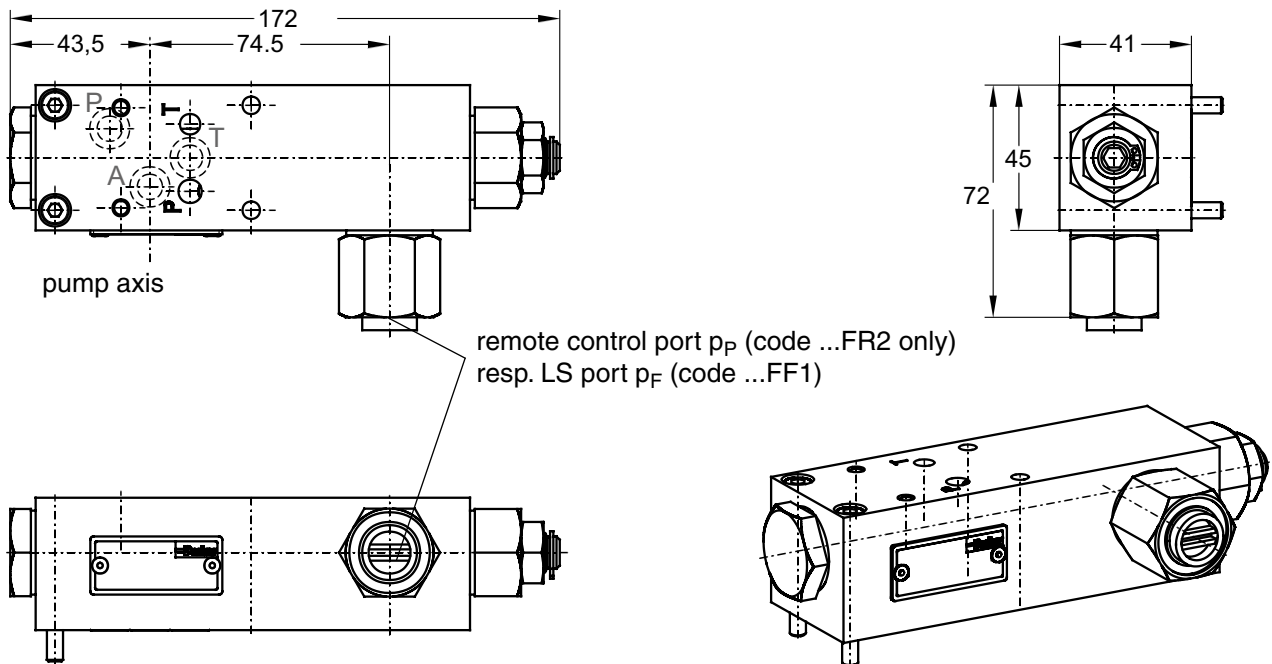

Compensators with code ...FR1 have no remote control port.

**Dimensions compensator with mounted pressure pilot valve, codes ...FRP, ...FFP**

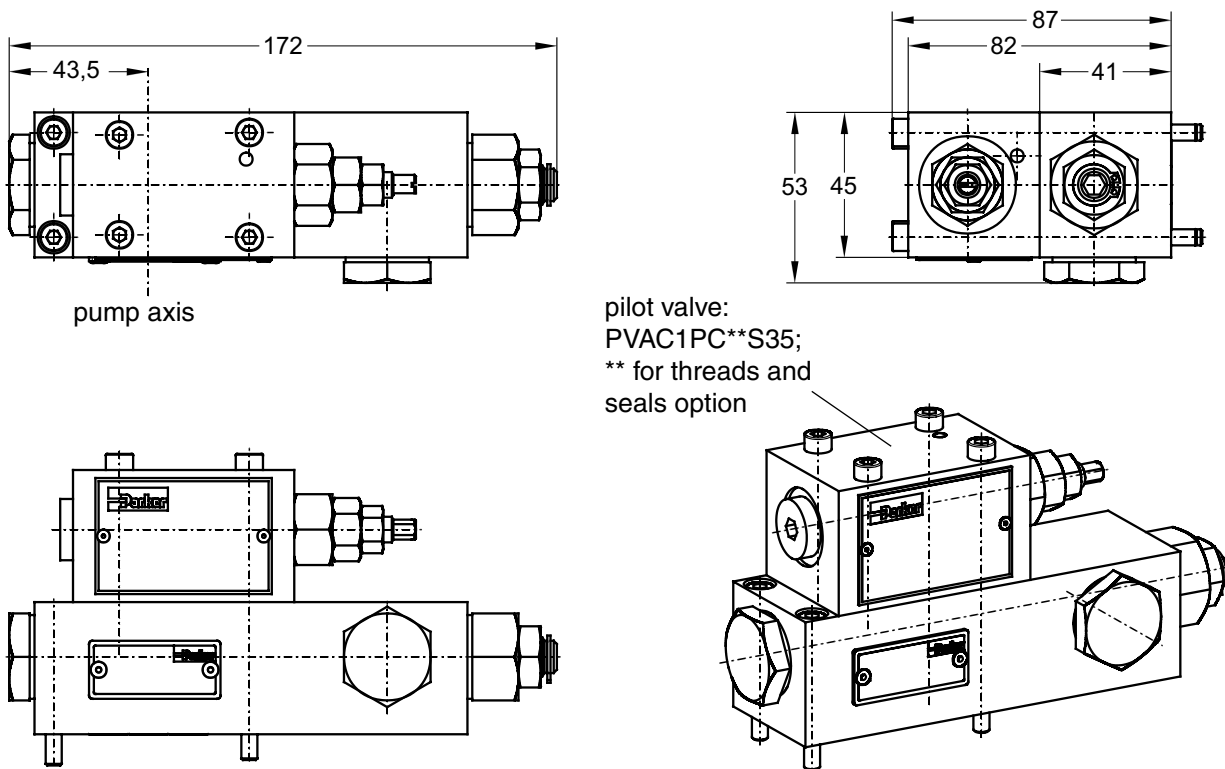

Compensators with codes ...FRD, ...FFD have a proportional pressure pilot valve type PVACPPC\*\*35 mounted;  
 Compensators with codes ...FRK, ...FFK have a proportional pressure pilot valve type PVACREC\*\*35 mounted;  
 \*\* for threads and seals option;

Dimensions of pilot valves see following pages.

Dimensions for horse power compensator \*L\* and \*C\* are identical to FR\* and FF\*.

**Dimensions two-spool load sensing compensator, code ...FT1, ...FT2, ...FTP**

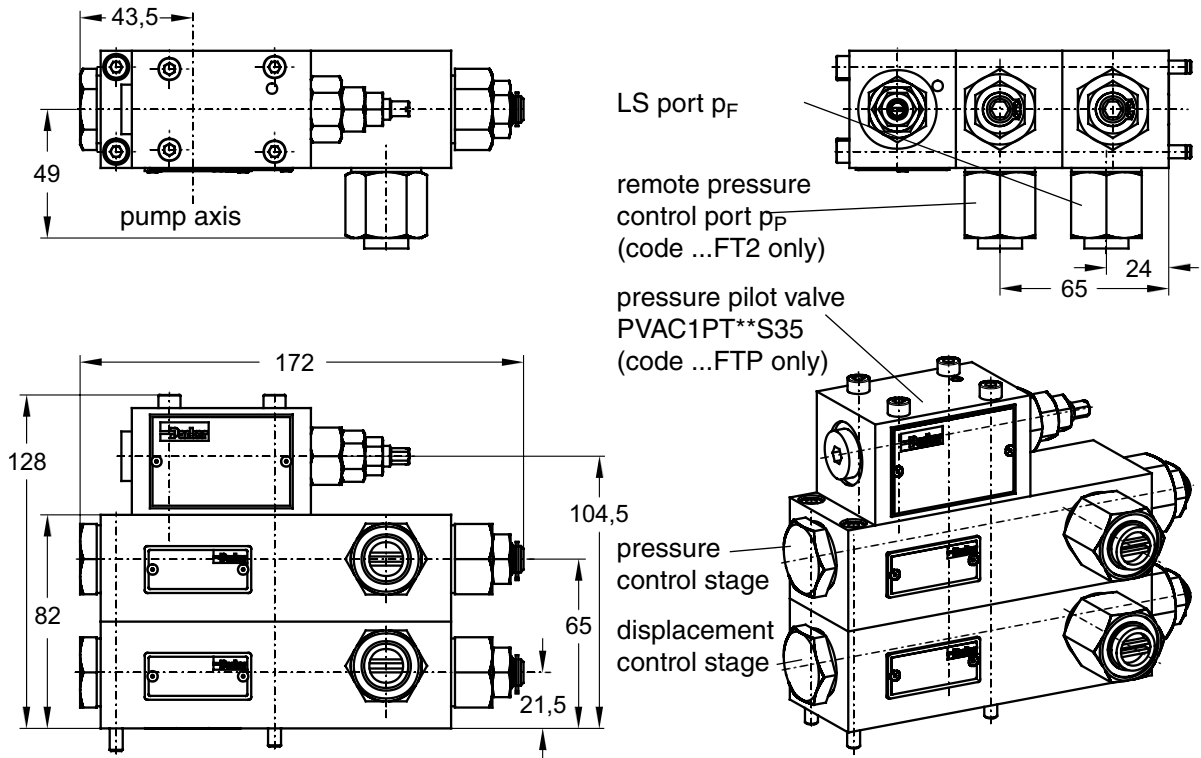

**Dimensions two-spool load sensing compensator with proportional pressure pilot valve, code ...FTK**

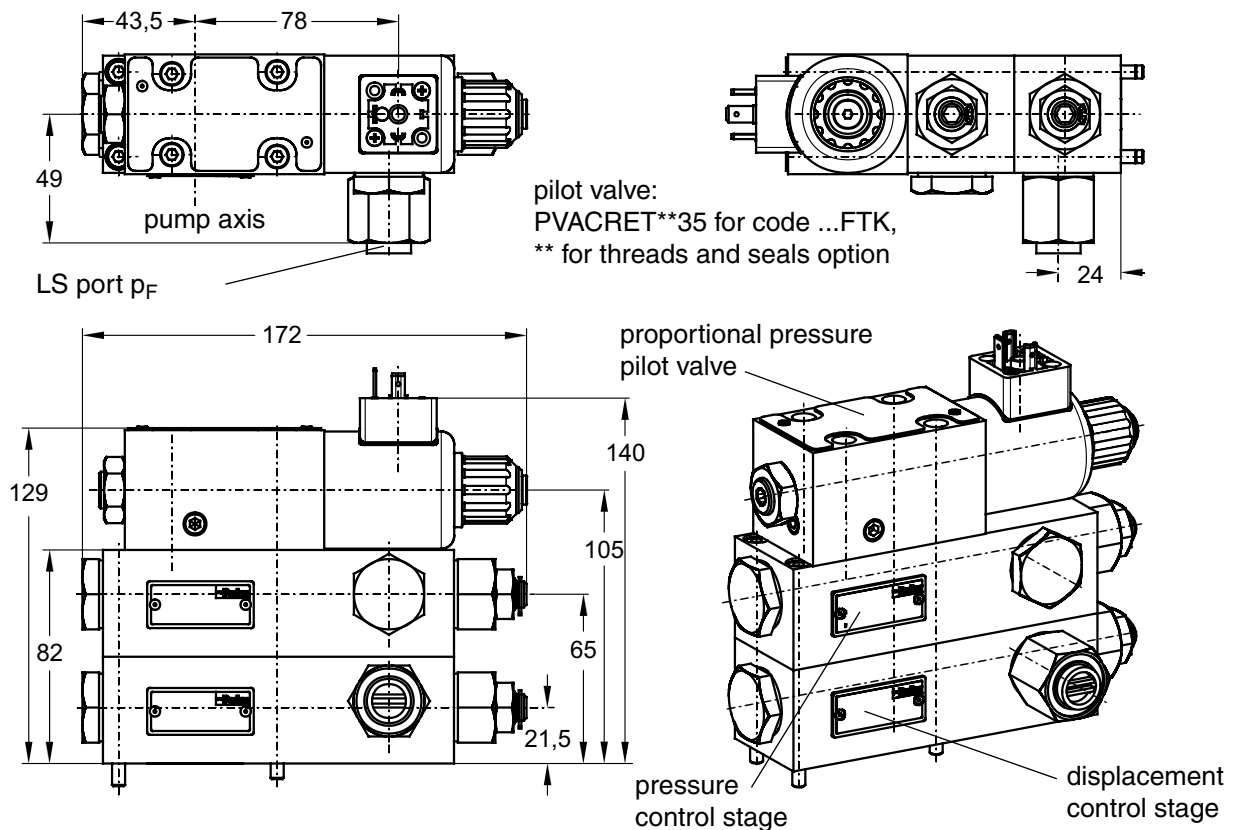

**Dimensions proportional displacement control, code ...FPV**

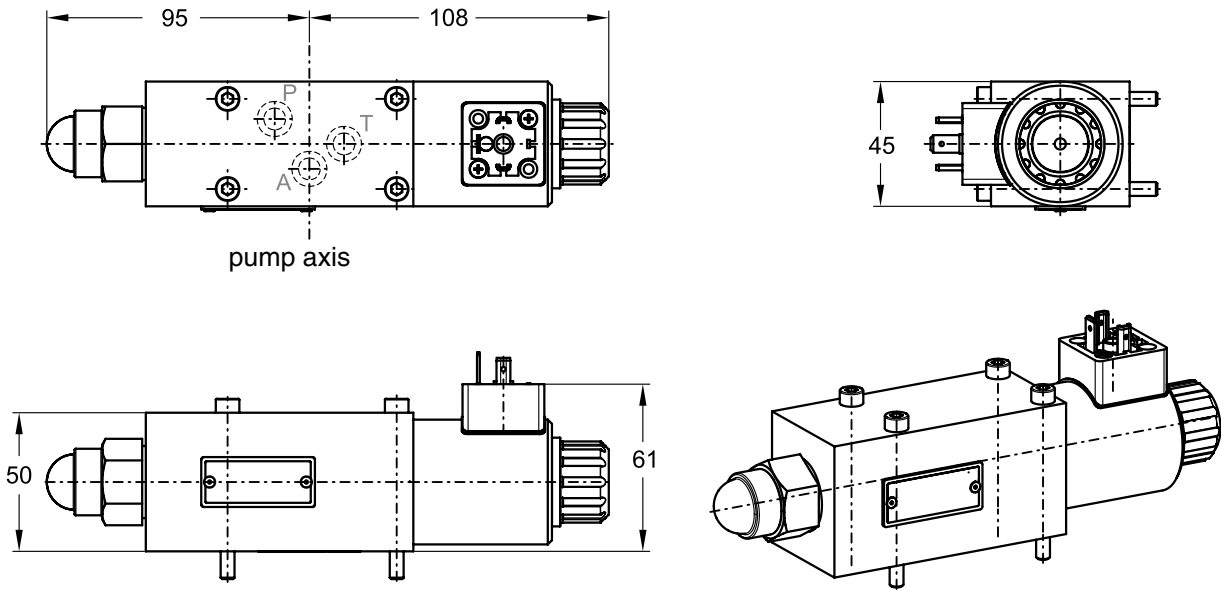

**Dimensions proportional p/Q control, codes ...UPR, ...UPK, ...UPM**

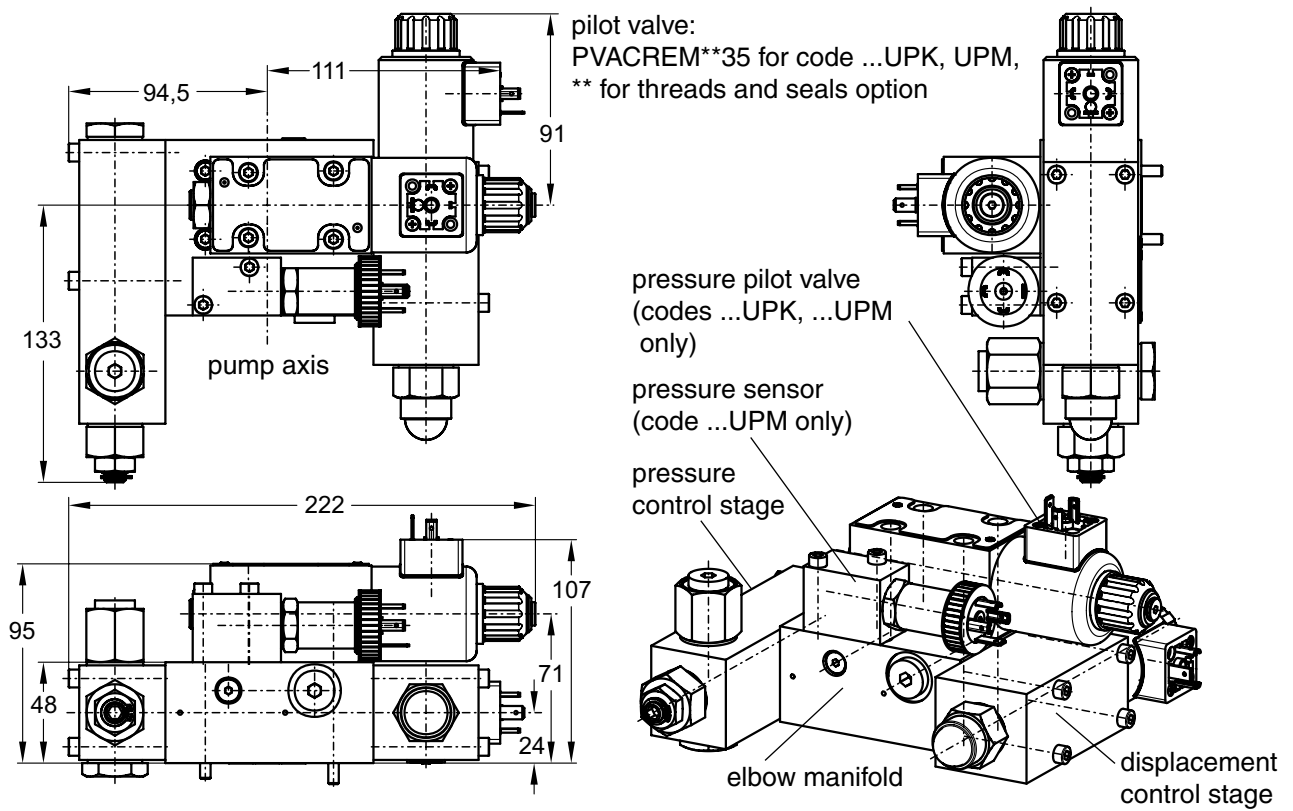

**Standard pressure compensator, code F\*S**

The standard pressure compensator adjusts the pump displacement according to the actual need of the system in order to keep the pressure constant.

As long as the system pressure at outlet port P is lower than the set pressure (set as spring preload of the compensator spring) the working port A of the compensator valve is connected to the case drain and the piston area is unloaded. Bias spring and system pressure on the annulus area keep the pump at full displacement.

When the system pressure reaches the set pressure the compensator valve spool connects port P<sub>1</sub> to A and builds up a pressure at the servo piston resulting in a downstroking of the pump. The displacement of the pump is controlled in order to match the flow requirement of the system.

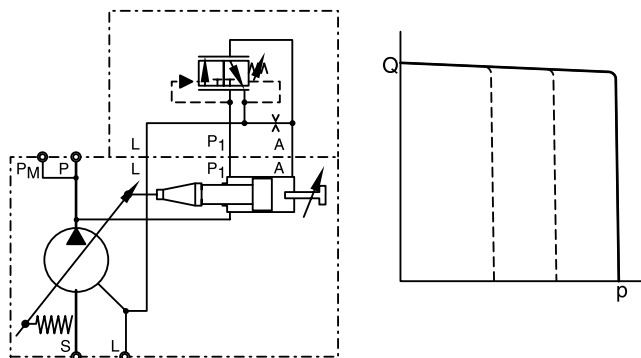

**Remote pressure compensator, code FRC**

While at the standard pressure compensator the pressure is set directly at the compensator spring, the setting of the remote pressure compensator can be achieved by any suitable pilot pressure valve connected to pilot port P<sub>P</sub>. The pilot flow supply is internal through the valve spool.

The pilot flow is 1 - 1.5 l/min. The pilot valve can be installed remote from the pump in some distance. That allows pressure setting e. g. from the control panel of the machine. The remote pressure compensator typically responds faster and more precisely than the standard pressure compensator and is able to solve instability problems that may occur with a standard pressure compensator in critical applications.

The pressure pilot valve can also be electronically controlled (proportional pressure valve) or combined with a directional control valve for low pressure standby operation.

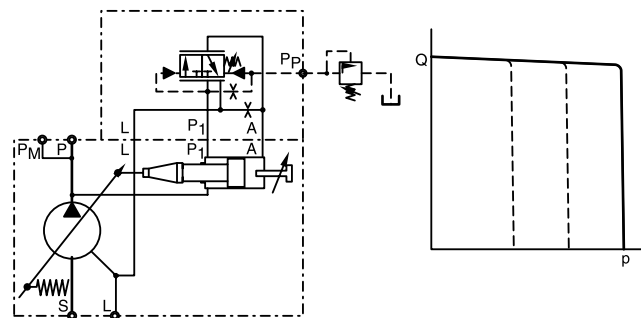

**Remote pressure compensator, code FR1**

Version \*FR1 of the remote pressure compensator provides on its top side an interface NG6, DIN 24340 (CETOP 03 at RP35H, NFPA D03).

This interface allows a direct mounting of a pilot valve (see option \*FRP and \*FRK page 7). Beside manual or electrohydraulic operated valves it is also possible to mount complete multiple pressure circuits directly on the compensator body. Parker offers a variety of these compensator accessories ready to install.

All remote pressure compensators have a factory setting of 15 bar differential pressure. With this setting, the controlled pressure at the pump outlet is higher than the pressure controlled by the pilot valve.

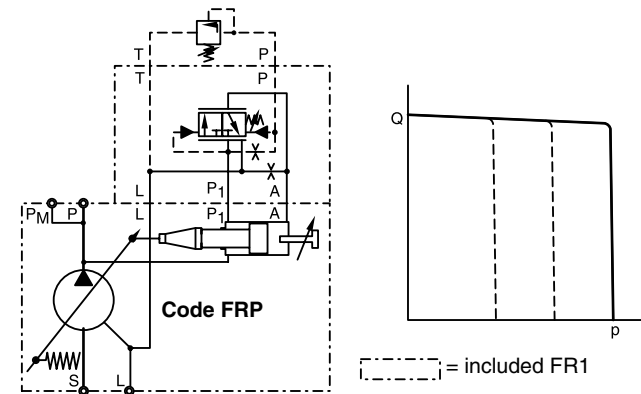

**Load-Sensing compensator, code FFC**

The load-sensing compensator has an external pilot pressure supply. Factory setting for the differential pressure is 10 bar. The input signal to the compensator is the differential pressure at a main stream resistor. A load-sensing compensator represents mainly a flow control for the pump output flow, because the compensator keeps the pressure drop at the main stream resistor constant.

A variable input speed or a varying load(-pressure) has consequently no influence on the output flow of the pump and the speed of the actuator.

By adding a pilot orifice (Ø 0.8 mm) and a pressure pilot valve pressure compensation can be added to the flow control function. See the circuit diagram below, left.

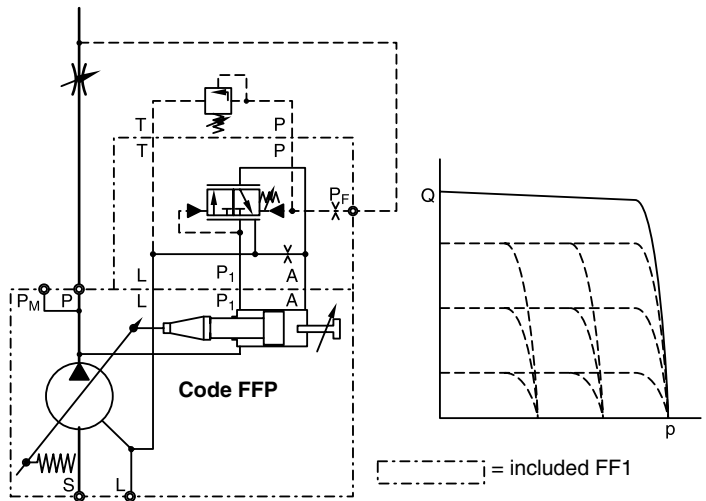
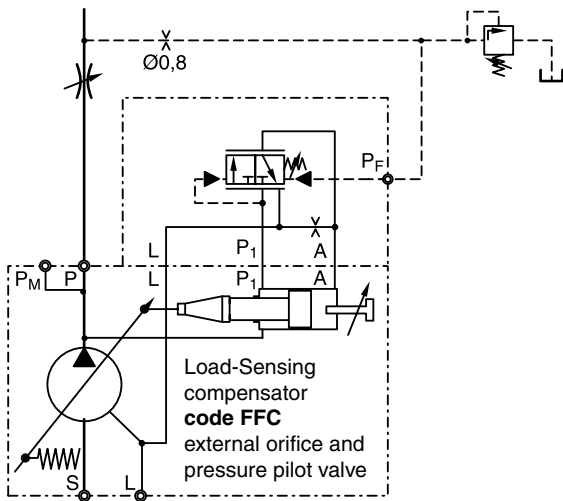
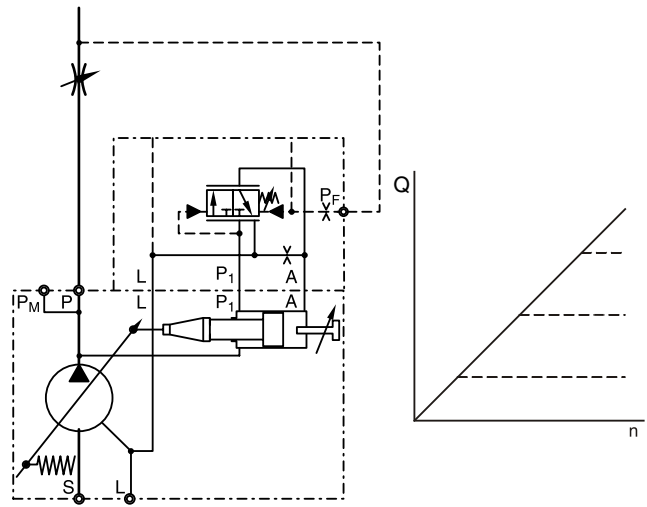

Shown above is **load-sensing compensator, code FF1** with an NG6 interface on top of the control valve. That allows direct mounting of a pilot valve for pressure compensation (see option \*FFP and \*FFK page 7). This version includes the pilot orifice.

Due to the interaction of flow and pressure compensation this package has not the "ideal" control characteristic. The deviation is caused by the pilot valves characteristic.

If a more accurate pressure compensation is required, the **2-valve load-sensing compensator code FT1** can be used. The circuit diagram of this version is shown left.

Here the interaction of the two control functions is avoided by using two separate control valves for flow and pressure compensation.

The 2-valve compensator is equipped with an interface NG6 on the compensators top side.

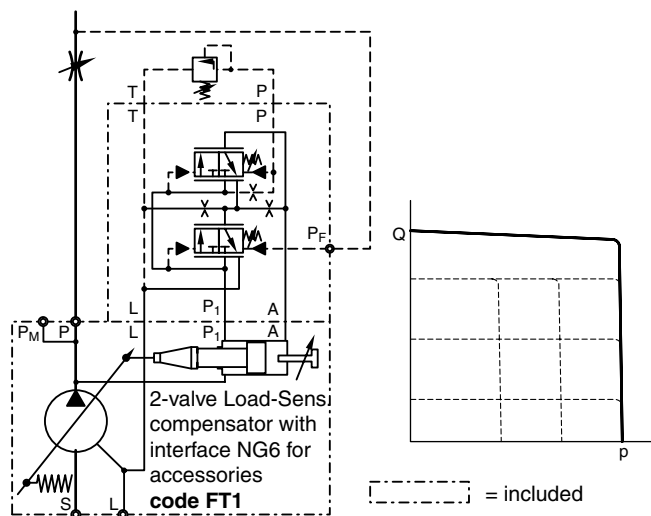



**Hydraulic-mechanical power compensator**

The hydraulic-mechanical power compensator consists of a modified remote pressure compensator (Code \*L\*) or of a modified load-sensing compensator (Code \*C\*) and a pilot valve. This pilot valve is integrated into the pump and is adjusted by a cam sleeve. The cam sleeve has a contour that is designed and machined for the individual displacement and the nominal power setting.

At a large displacement the opening pressure (given by the cam sleeve diameter) is lower than at small displacements. This makes the pump compensate along a constant power (torque) curve (see diagrams on opposite page).

For all nominal powers of standard electrical motors Parker offers a dedicated cam sleeve. The exchange of this cam sleeve (e. g.: to change power setting) can easily be done without disassembly of the pump.

On top of that an adjustment of the power setting can be done within certain limits by adjusting the preload of the pilot control cartridge spring. That allows an adjustment of a constant power setting for other than the nominal speeds (1500 min<sup>-1</sup>) or for other powers.

**Ordering code for the power option**

The first digit designates the power setting:

**Code G** = 11.0 kW etc. up to

**Code 3** = 132.0 kW

The second digit designates the pilot flow source:

**Code L** internal pilot pressure, remote pressure function.

**Code C** external pilot pressure, combines power compensation with load-sensing compensation.

The third digit designates the possibility to adjust the overriding pressure compensation:

**Code A** comes with a top side NG6/D03 interface on the control valve to mount any suitable pilot valve or Parker pump accessories.

**Code B** has a threaded pilot port P<sub>D</sub> (G1/4) to connect a remote pilot valve with piping.

**Code C** includes a pilot valve for manual pressure adjustment. Max. setting: 350 bar.

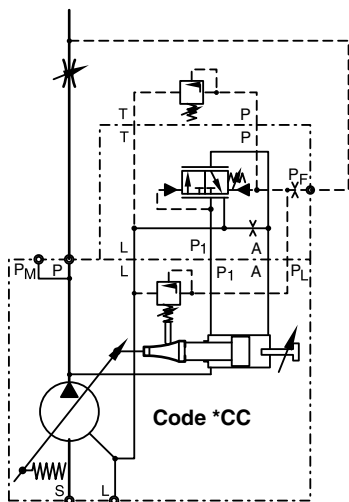
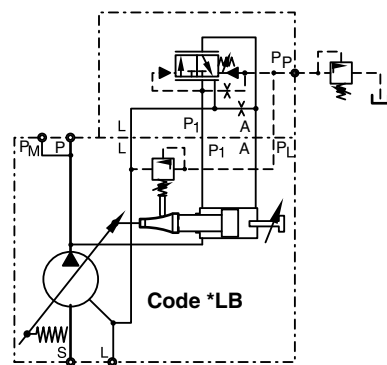
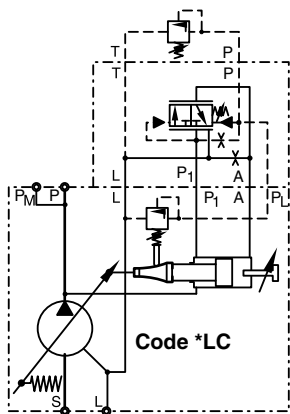

**Note:**  
 If \*CB is connected to an external pilot valve and 0.8 mm orifice the orifice in port P<sub>F</sub> has to be removed.

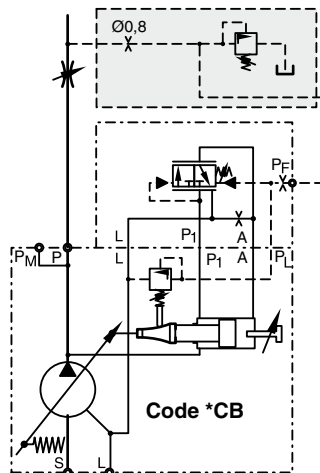

The graphs below show typical power curves, collected during following conditions:

- Speed :  $n = 1500 \text{ rev/min}$
- Temperature :  $t = 50 \text{ }^\circ\text{C}$
- Fluid : HLP, ISO VG46
- Viscosity :  $v = 46 \text{ mm}^2/\text{s}$  at  $40 \text{ }^\circ\text{C}$

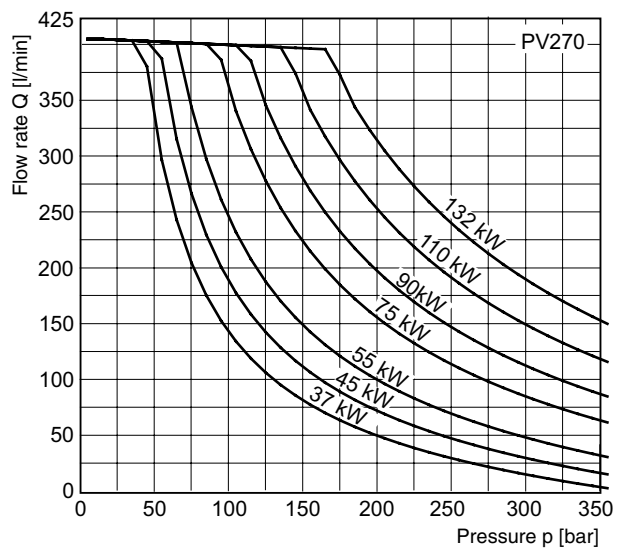
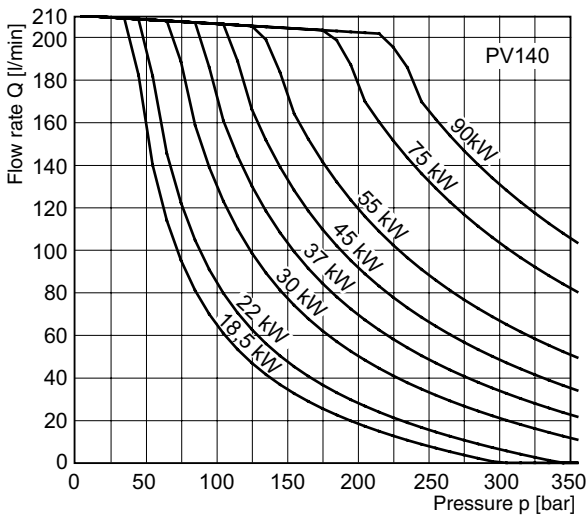
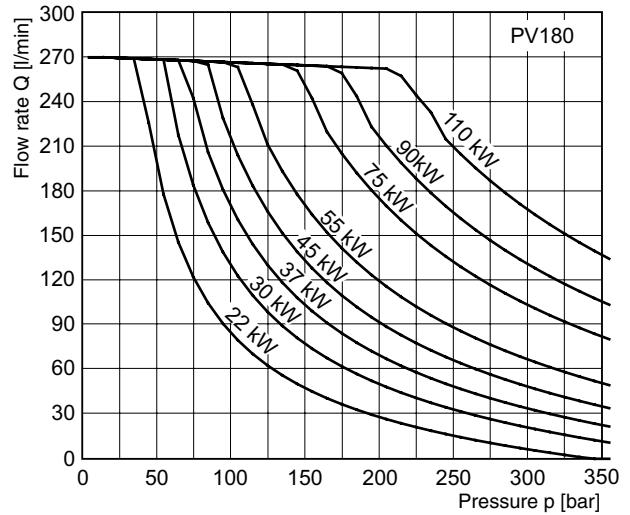
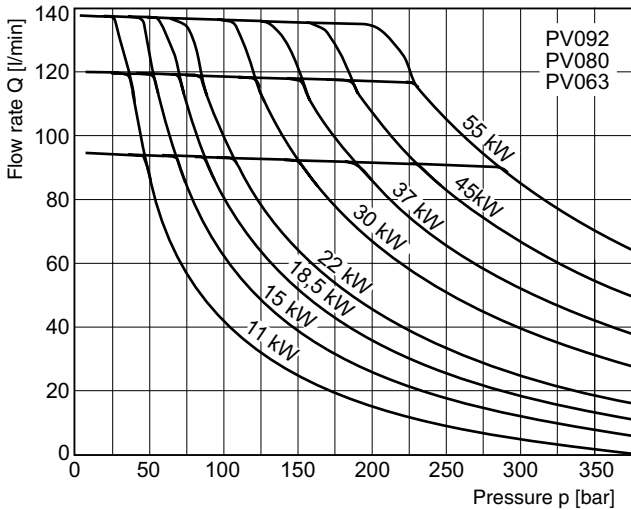

**Proportional displacement control, code FPV**

The proportional displacement control allows the adjustment of the pumps output flow with an electrical input signal.

The actual displacement of the pump is monitored by an LVDT and compared with the commanded displacement in an electronic control module PQDXXA. The command is given as an electrical input signal (0 - 10 V or 0 resp. 4 - 20 mA) from the supervising machine control. The command can also be provided by a potentiometer. The electronic control module offers a stabilized 10 V source to supply the potentiometer.

The electronic module compares permanently the input command and the actual displacement by powering the proportional solenoid of the control valve. A deviation from the commanded displacement leads to a modulation of the input current to the solenoid. The control valve then changes the control pressure (port A) until the correct displacement is adjusted.

Version FPV of the proportional control does not provide a pressure compensation. The hydraulic circuit must be protected by a pressure relief valve.

**Proportional displacement control with overriding pressure control, codes UPR, UPK and UPM**

Compensator version **\*UPR** provides electro- hydraulic displacement control and pressure stage mounted on elbow manifold. The elbow manifold provides NG6/D03 interface on top to mount a pressure pilot valve (not included in **\*UPR**).

When using a proportional pressure pilot valve an electro-hydraulic p/Q control can be realized. The proportional pressure pilot valve PVACRE..35 is included in compensator version **\*UPK**. By using the digital module PQDXXA-Z00 it is possible to control the displacement proportionally with overriding open loop proportional pressure control.

Compensator version **\*UPM** is completed by a pressure transducer Parker SCP 8181 CE. In combination with control module PQDXXA-Z00 a closed loop pressure control of pump outlet pressure is available. The control module also offers an electronic power limiter in addition to closed loop pressure control with this compensator option.

**Note:**

Minimum pump pressure (appr. 20 to 30 bar) depends on system and pilot valve used. Pump cannot fully downstroke if system pressure is below that level.

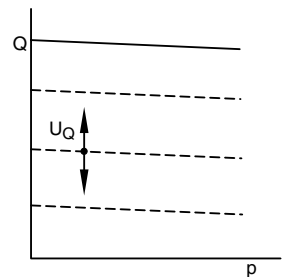
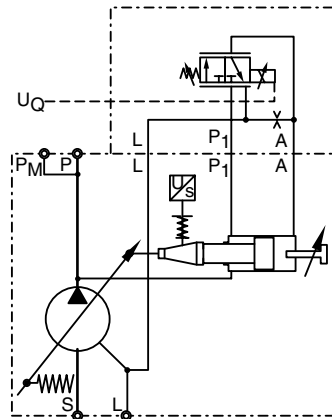

[dashed box] = included FPV

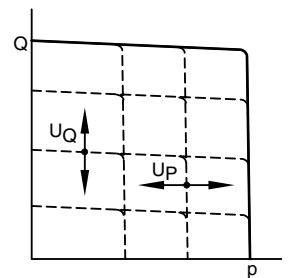
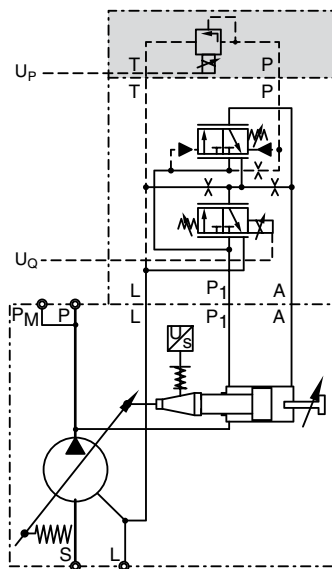

[dashed box] included UPR  
[shaded box] additionally at UPK

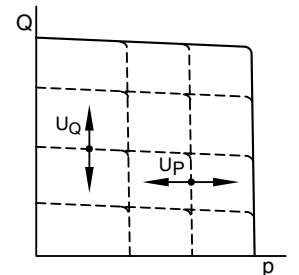
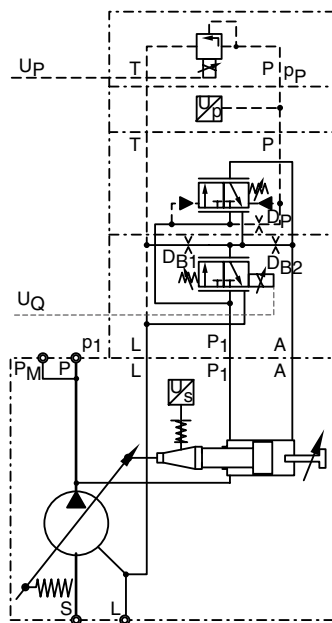

[dashed box] = included UPM

The digital control module code PQDXXA-Z00 is designed for rail mounting.

**Features**

- Digital control circuit
- Parameter setting via RS-232 interface
- All settings (ramps, MIN/MAX, control parameters) can be stored digitally and recalled from a PC to duplicate settings to other modules
- Ramp time up to 60 seconds
- Compatible to the relevant european EMC specifications
- Easy to use PC based setup software
- Covers all displacements from 16 to 270 cm³/rev
- Covers all functions: displacement control, displacement control with open loop pressure control, displacement control with closed loop pressure control and displacement control with closed loop pressure control and electronic power limitation.

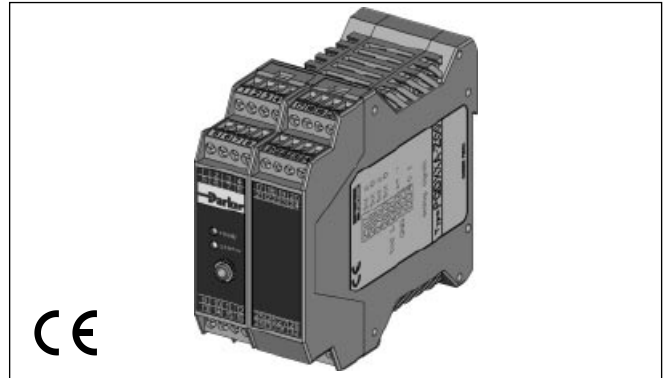

**Ordering code**

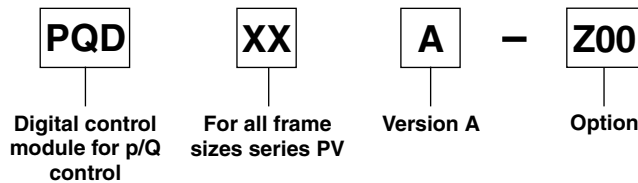

**Technical data**

Mounting style		Snap-on mounting for EN50022 rail
Body material		Polycarbonate
Inflammation class		V2...V0 acc. UL 94
Mounting position		any
Env. temperature range	[°C]	-20...+55
Protection class		IP 20 acc. DIN 40 050
Weight	[g]	160
Duty ratio	[%]	100
Supply voltage	[V]	18...30VDC, ripple <5% eff.
Rush in current	[A]	22 for 0.2 ms
Current consumption	[A]	< 4 for p/Q control ; < 2 for Q-control
Resolution	[%]	0.025 (power 0.1)
Interface		RS232C, 9600 baud, 3.5 mm cinch
EMC		EN 50 081-2, EN 50 082-2
Connectors		Screw terminals 0.2...2.5 mm², plug in style
Cables	[mm²]	1.5 (AWG 16) overall braid shield, for supply and solenoid connection 0.5 mm² (AWG 20) overall braid shield, for sensor and command signal connections
Max. cable length	[m]	50

For programming the module via PC, an interface cable is needed, please order part number PQDXXA-KABEL separately.

**Programming software**

The programming of the p/Q control module is done in an easy to learn mode. To select the pump model and size and to set the control parameters the program **ProPVplus** must be started. This program runs under WINDOWS® 95 and higher.

The latest version of this software can be downloaded at the following internet address:

[http://www.parker.com/euro\\_hcd](http://www.parker.com/euro_hcd)

The software offers the following features:

A **TERMINAL** window to set or read out the control parameters of the module. Settings as well as comments entered in the terminal window can be stored also in RTFformat (opens e. g. under WORD or other text editors)

A **MONITOR** window allows to display process variables in numerical format.

An **OSZILLOSKOP** window displays process variables as curves. The oscilloscope offers a start - stop function. The images can be saved and stored e. g. for import into other programs.

**Features**

- Display and documentation of parameter sets
- Save and reload of optimized parameter sets
- Offers oscilloscope function for easy performance evaluation and optimization
- Pre-optimized parameter sets for all PVplus piston pump
- Sizes already in E<sup>2</sup>PROM memory

**Diagrams**

Typical static characteristic

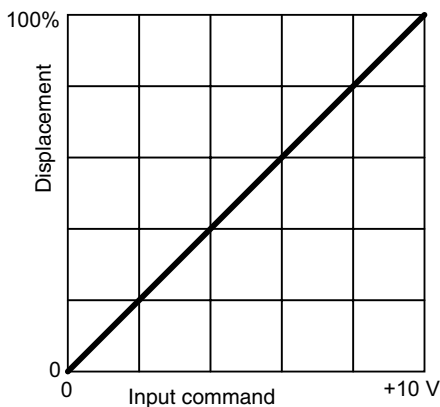

Typical dynamic characteristic

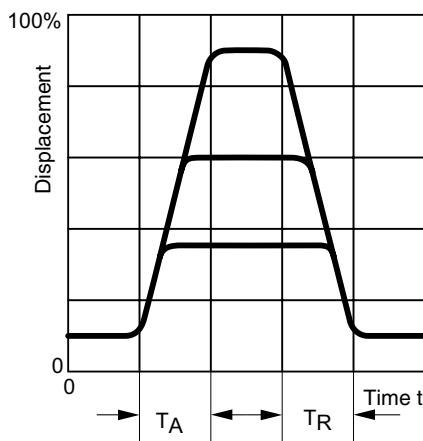

**Response time (50-300 bar)**

Pump size	TA [ms]	TR [ms]
PV092	90	90
PV180	170	170
PV270	250	250

<b>PV</b>	<b>AC</b>								<b>35</b>	
For PV pump series	Accessories for compensators	Function	Mounting bolts	Threads	Seals	Adjustment	Solenoid	Solenoid accessories	Nominal pressure 350 bar	
Code	Function		Code	Threads	Code	Seals	Code	Adjustment	Code	Solenoid accessories
1P	Max. pressure relief		M	Metric	N	NBR	S	Spindle with lock nut	omit	For function 1P
1E	1 pressure, electrical unloading		S	SAE / UNC	V	FPM			C	Conduit box with free wires
2P	2 pressures, electrical selection								W	DIN plug socket without plug
2E	2 pressures + stands electrical selection low pressure default									
2M	2 pressures + stands electrical selection stand by default									
			Code	Mounting bolts					Code	Solenoid voltage
			C	For single compensators type R or F					omit	For function 1P
			S	Without bolts					Y	110V/50Hz - 120V/60Hz
			M	For code UP*/MT* + DS 45					T	220V/50Hz - 240V/60Hz
			U	For code UP* + DS 42					J	24V DC

Compensator accessory only available on pump, not as single items (replacement kit see spare part list PVI-PVAC-UK).

**Dimensions**

**PVAC1P\***

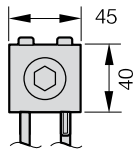
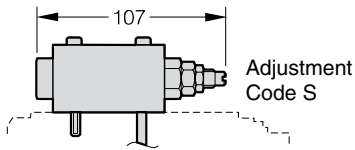

**PVAC1E\***

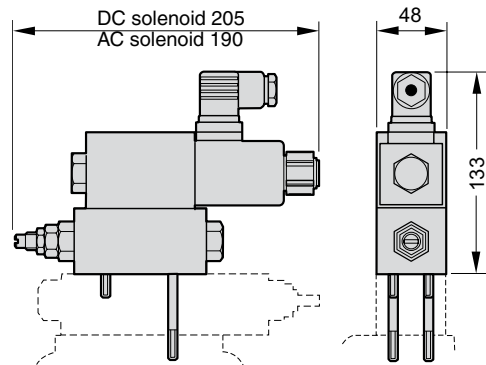

**PVAC2P\***

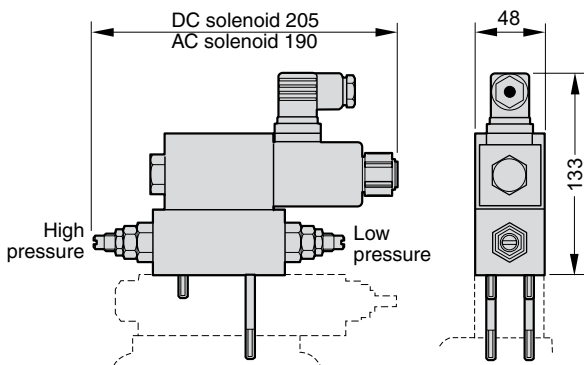

**PVAC2M\*/PVAC2E\***

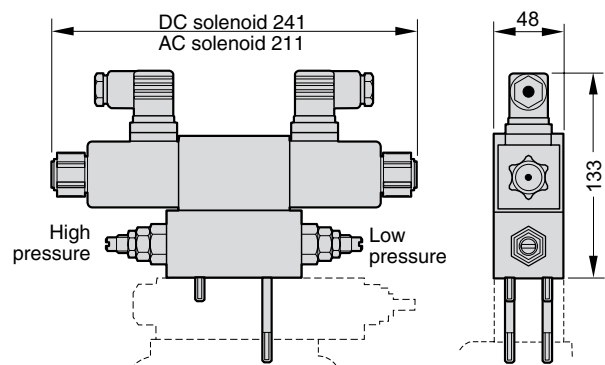

**Schematics PVAC1P\***

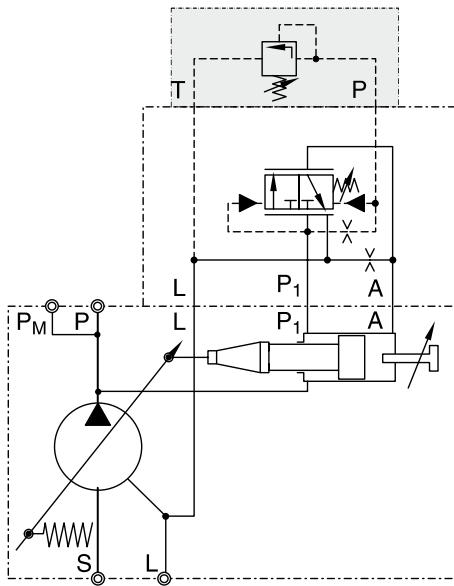

**Schematics PVAC1E\***

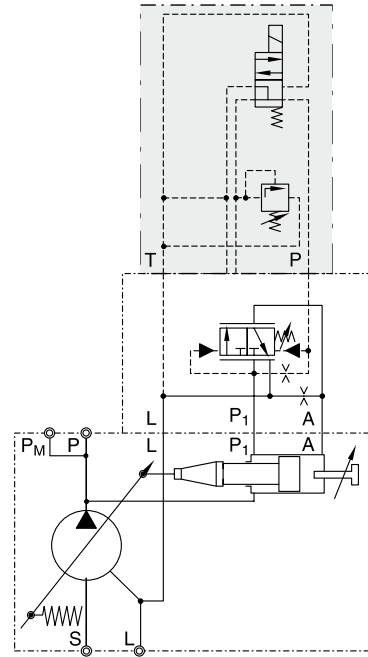

**Schematics PVAC2P\***

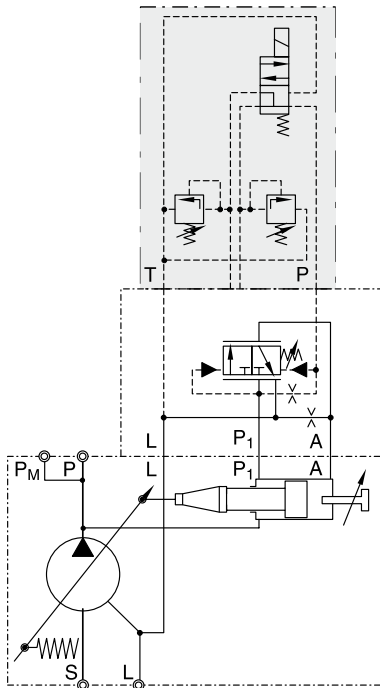

**Schematics PVAC2M\*/PVAC2E\***

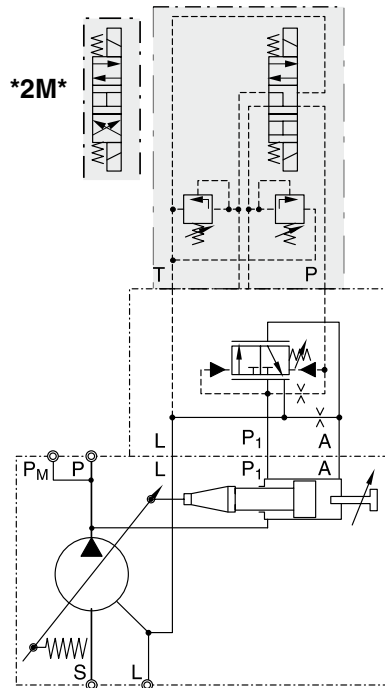

**Ordering code proportional pressure control valve**

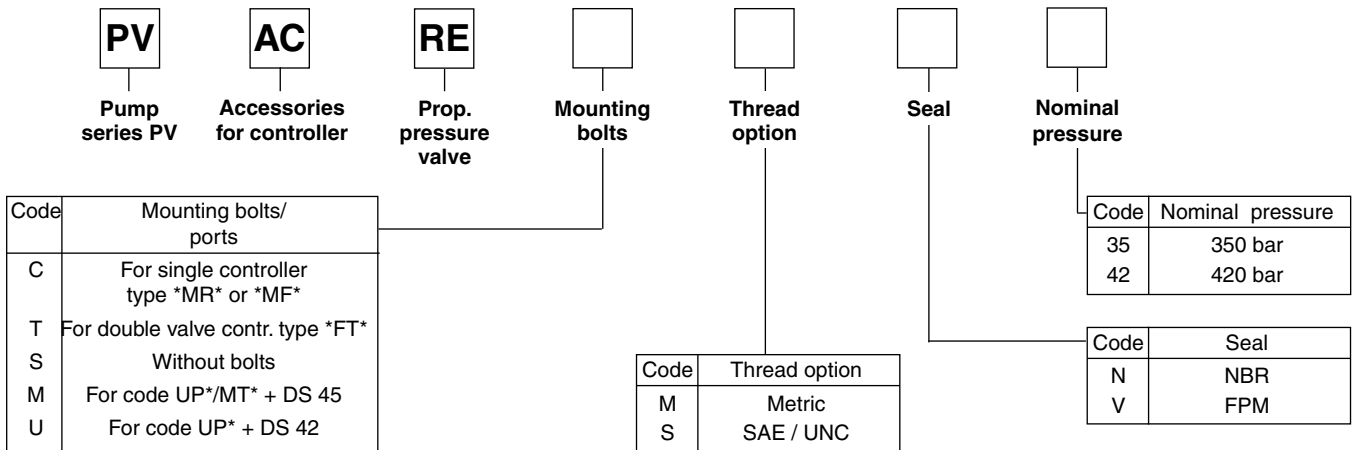

**Proportional pressure control valve**

Proportional pressure pilot valves of series PVACRE\* (RE06...) are powered by external electronic modules

(see catalogue HY11-3500 for reference). They allow an infinite electronic adjustment of the pumps compensating pressure.

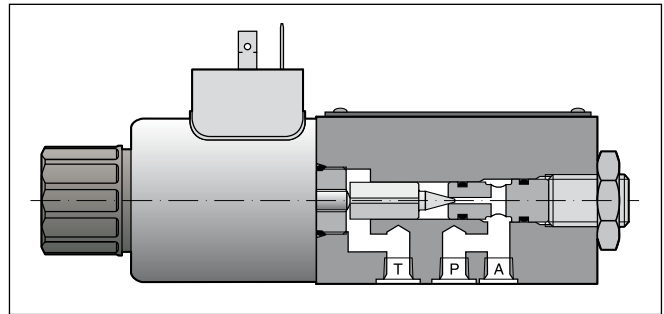
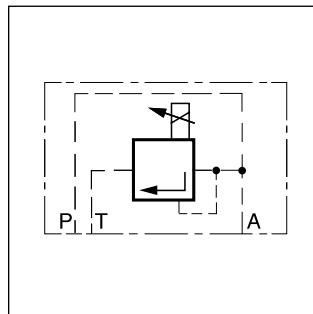

**Schematic PVACRE\***

**Dimensions PVACRE\***

**Example for PVACRE\* mounted**

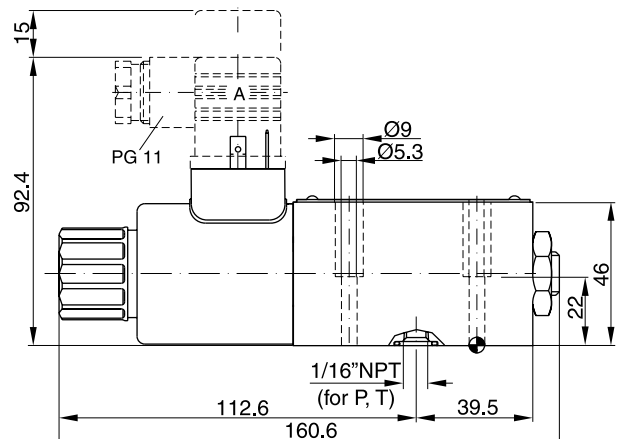
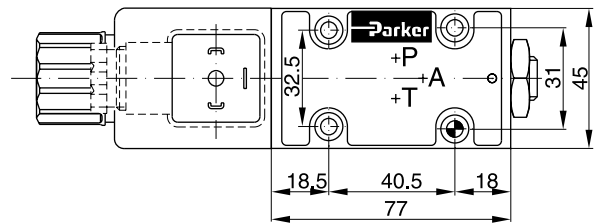
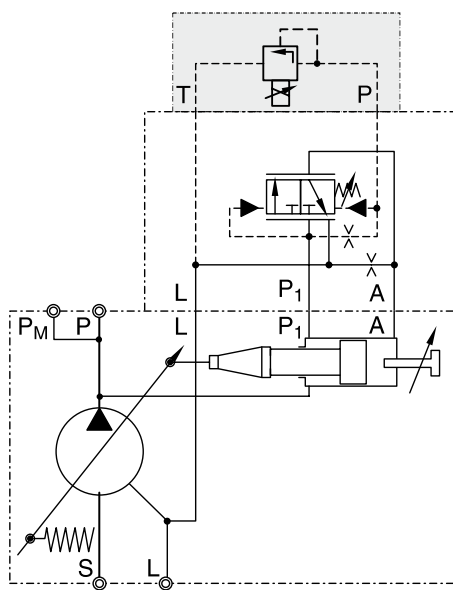









## **WARNING**

**FAILURE OR IMPROPER SELECTION OR IMPROPER USE OF THE PRODUCTS AND/OR SYSTEMS DESCRIBED HEREIN OR RELATED ITEMS CAN CAUSE DEATH, PERSONAL INJURY AND PROPERTY DAMAGE.**

This document and other information from Parker Hannifin Corporation, its subsidiaries and authorized distributors provide product and/or system options for further investigation by users having technical expertise. It is important that you analyze all aspects of your application, including consequences of any failure, and review the information concerning the product or system in the current product catalogue. Due to the variety of operating conditions and applications for these products or systems, the user, through its own analysis and testing, is solely responsible for making the final selection of the products and systems and assuring that all performance, safety and warning requirements of the application are met.

The products described herein, including without limitation, product features, specifications, designs, availability and pricing, are subject to change by Parker Hannifin Corporation and its subsidiaries at any time without notice.

## **Offer of Sale**

Please contact your Parker representation for a detailed "Offer of Sale".

# Parker Worldwide

**AE – UAE, Dubai**  
Tel: +971 4 8875600  
parker.me@parker.com

**AR – Argentina, Buenos Aires**  
Tel: +54 3327 44 4129

**AT – Austria, Wiener Neustadt**  
Tel: +43 (0)2622 23501-0  
parker.austria@parker.com

**AT – Eastern Europe, Wiener Neustadt**  
Tel: +43 (0)2622 23501 970  
parker.easteurope@parker.com

**AU – Australia, Castle Hill**  
Tel: +61 (0)2-9634 7777

**AZ – Azerbaijan, Baku**  
Tel: +994 50 2233 458  
parker.azerbaijan@parker.com

**BE/LX – Belgium, Nivelles**  
Tel: +32 (0)67 280 900  
parker.belgium@parker.com

**BR – Brazil, Cachoeirinha RS**  
Tel: +55 51 3470 9144

**BY – Belarus, Minsk**  
Tel: +375 17 209 9399  
parker.belarus@parker.com

**CA – Canada, Milton, Ontario**  
Tel: +1 905 693 3000

**CH – Switzerland, Etoy**  
Tel: +41 (0) 21 821 02 30  
parker.switzerland@parker.com

**CN – China, Shanghai**  
Tel: +86 21 5031 2525

**CZ – Czech Republic, Klecany**  
Tel: +420 284 083 111  
parker.czechrepublic@parker.com

**DE – Germany, Kaarst**  
Tel: +49 (0)2131 4016 0  
parker.germany@parker.com

**DK – Denmark, Ballerup**  
Tel: +45 43 56 04 00  
parker.denmark@parker.com

**ES – Spain, Madrid**  
Tel: +34 902 33 00 01  
parker.spain@parker.com

**FI – Finland, Vantaa**  
Tel: +358 (0)20 753 2500  
parker.finland@parker.com

**FR – France, Contamine s/Arve**  
Tel: +33 (0)4 50 25 80 25  
parker.france@parker.com

**GR – Greece, Athens**  
Tel: +30 210 933 6450  
parker.greece@parker.com

**HK – Hong Kong**  
Tel: +852 2428 8008

**HU – Hungary, Budapest**  
Tel: +36 1 220 4155  
parker.hungary@parker.com

**IE – Ireland, Dublin**  
Tel: +353 (0)1 466 6370  
parker.ireland@parker.com

**IN – India, Mumbai**  
Tel: +91 22 6513 7081-85

**IT – Italy, Corsico (MI)**  
Tel: +39 02 45 19 21  
parker.italy@parker.com

**JP – Japan, Fujisawa**  
Tel: +(81) 4 6635 3050

**KR – South Korea, Seoul**  
Tel: +82 2 559 0400

**KZ – Kazakhstan, Almaty**  
Tel: +7 7272 505 800  
parker.easteurope@parker.com

**LV – Latvia, Riga**  
Tel: +371 6 745 2601  
parker.latvia@parker.com

**MX – Mexico, Apodaca**  
Tel: +52 81 8156 6000

**MY – Malaysia, Subang Jaya**  
Tel: +60 3 5638 1476

**NL – The Netherlands, Oldenzaal**  
Tel: +31 (0)541 585 000  
parker.nl@parker.com

**NO – Norway, Ski**  
Tel: +47 64 91 10 00  
parker.norway@parker.com

**NZ – New Zealand, Mt Wellington**  
Tel: +64 9 574 1744

**PL – Poland, Warsaw**  
Tel: +48 (0)22 573 24 00  
parker.poland@parker.com

**PT – Portugal, Leca da Palmeira**  
Tel: +351 22 999 7360  
parker.portugal@parker.com

**RO – Romania, Bucharest**  
Tel: +40 21 252 1382  
parker.romania@parker.com

**RU – Russia, Moscow**  
Tel: +7 495 645-2156  
parker.russia@parker.com

**SE – Sweden, Spånga**  
Tel: +46 (0)8 59 79 50 00  
parker.sweden@parker.com

**SG – Singapore**  
Tel: +65 6887 6300

**SK – Slovakia, Banská Bystrica**  
Tel: +421 484 162 252  
parker.slovakia@parker.com

**SL – Slovenia, Novo Mesto**  
Tel: +386 7 337 6650  
parker.slovenia@parker.com

**TH – Thailand, Bangkok**  
Tel: +662 717 8140

**TR – Turkey, Istanbul**  
Tel: +90 216 4997081  
parker.turkey@parker.com

**TW – Taiwan, Taipei**  
Tel: +886 2 2298 8987

**UA – Ukraine, Kiev**  
Tel: +380 44 494 2731  
parker.ukraine@parker.com

**UK – United Kingdom, Warwick**  
Tel: +44 (0)1926 317 878  
parker.uk@parker.com

**US – USA, Cleveland (industrial)**  
Tel: +1 216 896 3000

**US – USA, Lincolnshire (mobile)**  
Tel: +1 847 821 1500

**VE – Venezuela, Caracas**  
Tel: +58 212 238 5422

**ZA – South Africa, Kempton Park**  
Tel: +27 (0)11 961 0700  
parker.southafrica@parker.com

European Product Information Centre  
Free phone: 00 800 27 27 5374  
(from AT, BE, CH, CZ, DE, DK, EE, ES, FI, FR, IE, IT, NL, NO, PL, RU, SE, SK, UK, ZA)



**Parker Hannifin Ltd.**  
Tachbrook Park Drive  
Tachbrook Park, Warwick CV34 6TU  
United Kingdom  
Tel.: +44 (0) 1926 317 878  
Fax: +44 (0) 1926 317 855  
www.parker.com