

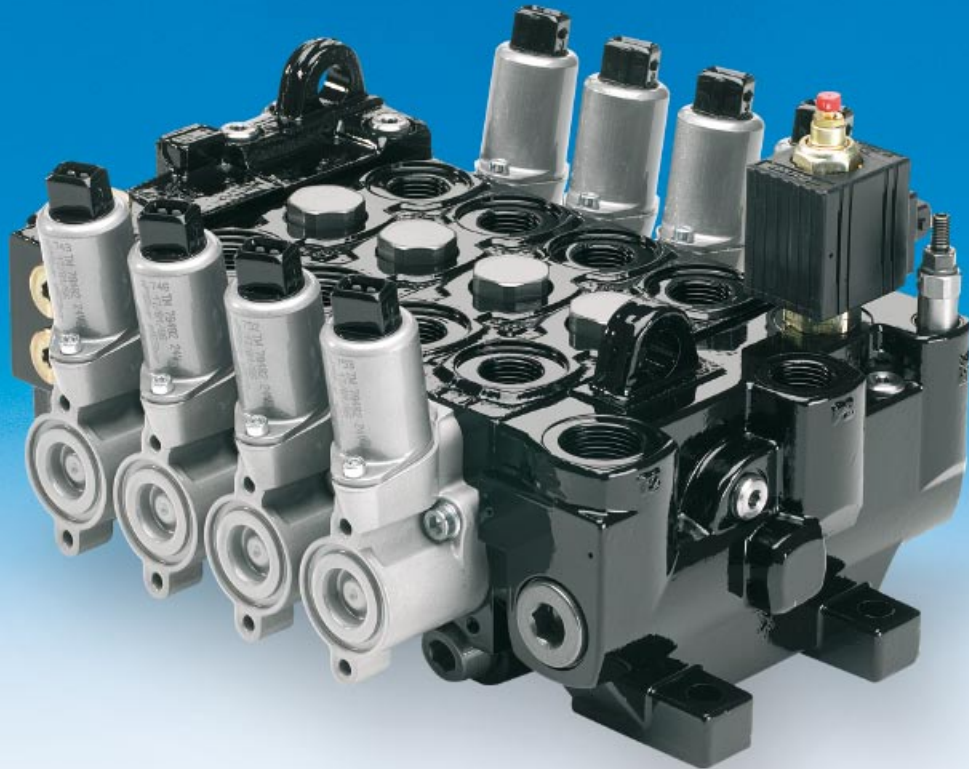

# ***Directional Control Valve P70***

*Open or Closed Centre  
Proportional Valve Series*

*Catalogue HY17-8546/UK  
January, 2007*



## Catalogue layout

This catalogue is designed to give an overview of the P70 directional valve and to show how it can be customised to meet your needs exactly. Apart from general information and basic technical data therefore, the catalogue contains descriptions of the variety of options available for the different function areas of the valve. After you have studied the options and made your selection, we will tailor your valve to meet your operating and control criteria.

Each function area is given as a subheading, followed by a brief description. When several optional functions are available for the same function area, the subheading is followed by an "Item number" in square brackets, e.g. **Main pressure relief valve [16]**. This is followed by a series of coded options, e.g. **PS**,

**PB, Y**, together with a brief description of what each code represents. Alternatively, one or more pressure, flow or voltage options are given.

On pages 12 and 13 there are general circuit diagrams showing the basic functions of the P70 valve, together with the item numbers and letter codes used to represent them. Naturally, the same item numbers and letter codes are used in all sub-circuit diagrams that appear elsewhere in the catalogue in conjunction with descriptions of the respective function areas. All sub-circuit diagrams have been extracted from the general circuit diagram. Please note that, unless otherwise stated, all sections and views of the valves have been drawn as seen from the inlet section.

## How to order your valve

Parker has developed a computer program to specify the P70, so that the configuration of your valve can be optimised to give maximum performance in your particular hydraulic system.

Based on the demands on each individual machine function, the computer specifies the configuration of the valve to give optimal performance. It also generates complete documentation for your valve in the form of a detailed specification and hydraulic circuit diagram.

The program also generates a unique product designation that is subsequently stamped into the data plate on your valve. Your customised valve specifications remain on our database to facilitate rapid identification of your valve in the event of re-ordering or servicing.

## Early consultation with Parker saves time and money

Our experienced application engineers have in-depth knowledge of the different types of hydraulic system and the ways in which they work. They are at your disposal to offer qualified advice on the various combinations of functions and control characteristics you may require, and to advise how to obtain the best possible economy.

By consulting Parker early in the project planning stage, you are assured of a comprehensive hydraulic system that will give your machine the best possible operating and control characteristics, together with outstanding economy.

Subject to alteration without prior notice. The graphs and diagrams in this catalogue are typical examples only. While the contents of the catalogue are updated continually, the validity of the information given should always be confirmed. For more detailed information, please contact Parker Hannifin.

### Conversion factors

1 kg	= 2.2046 lb
1 N	= 0.22481 lbf
1 bar	= 14.504 psi
1 l	= 0.21997 UK gallon
1 l	= 0.26417 US gallon
1 cm <sup>3</sup>	= 0.061024 in <sup>3</sup>
1 m	= 3.2808 feet
1 mm	= 0.03937 in
9/5 °C + 32	= °F

<b>List of contents</b>	<b>Page</b>
General Information.....	4
Open Centre Systems, OC, (Valve with open centre, P70CF) .....	5
Control characteristics .....	5
Constant-pressure systems, CP, CPU, (Valve with closed centre, P70CP).....	6
Control characteristics .....	6
Load sensing systems, LS, (Valve with load sensing, P70LS) .....	7
Control characteristics .....	7
System connection .....	8
A. Power beyond connection, multi-valve system, P70CF only .....	8
B. Power beyond connection, single-valve system, P70CF only .....	8
C. Parallel connection, multi-valve system.....	9
Technical Data .....	10
Environmental characteristics.....	11
Hydraulic circuit diagram showing basic functions, standard valve .....	12
Hydraulic circuit diagram showing basic functions (actuators with closed spool end).....	13
Inlet Section.....	14
Type of inlet section [15].....	14
Main pressure relief valve [16].....	16
Pressure setting [17].....	16
Pump unloading [22].....	16
External pump unloading or multi-level main pressure relief function .....	17
Tank connection T2 [25].....	17
Pump connection P1 [26] .....	17
Pump connection P2 [27] .....	17
Mid-inlet section [90].....	18
Options, mid-inlet [93].....	19
Main pressure relief valve [94].....	19
Pressure setting [98].....	19
End Section .....	20
Type of end section [30].....	20
Tank connection T1 [33].....	20
Tank connection T3 [34].....	20
Series-connection function [36] .....	20
Reducing valve [37] .....	21
Pilot-oil strainer [39].....	21
Separate tank connection for pilot circuit [40].....	21
Spool Sections.....	22
Type of spool section [47] .....	22
Lever bracket [51] .....	23
Spool actuators [50].....	24
Hand-operated spool actuators with open spool end .....	24
Remote controlled ON/OFF spool actuators with open spool end .....	24
Remote controlled proportional spool actuators with closed spool end .....	25
Spool position indicator [52] .....	28
Spool function [60].....	29
Spool designation [69].....	29
Pressure gallery [66] .....	29
Choice of Spool .....	29
Pressure limiters in work ports [76A/B] .....	30
Port relief valve [76].....	30
Function blocks (manifolds) .....	31
Connectors, electrical .....	31
Hand levers for open and closed spool-actuators .....	32-33
Dimensional drawings, standard valve .....	34
Dimensional drawings, model with closed spool end .....	35
Dimensional drawings, spool actuators .....	36-38

[00] refers to item numbers in customer specification.



The P70 directional valve is of modular construction. It is designed for many different applications and used extensively in machines such as lorry cranes, mini-excavators, small wheeled loaders and concrete placing cranes. The P70 is available in three different versions: the **P70CF** with an open centre for fixed pumps, the **P70CP** with a closed centre for variable displacement pumps and the **P70LS** with a closed centre, coupled with a load sensing signal, to the variable displacement pump.

### Compact system construction

The P70 offers unique possibilities for the integration of application-adapted functions to give compact and total system solutions for a wide range of mobile machines.

### Freedom in machine design

In order to give the system designer a greater level of flexibility and freedom, the valve is designed to be either directly operated, or controlled by electric, pneumatic or hydraulic remote controls. A combination of these direct, and remote controls, can be utilised allowing a greater degree of component location and pilot media options.

### Economy

Thanks to its modular construction, the P70 can be optimised for both simple and complex functions. The possibility of integrating total function solutions gives low overall system costs. The valve can be modified or expanded as necessary to suit the needs of the customer.

### Safety

The valve is of robust construction, with each function unitised. This facilitates both training and servicing and contributes greatly to safety. Moreover, the valve can be fitted with a special inlet section that enables an emergency STOP function to be incorporated into the valve to meet the demands of the EC Machinery Directive in a uniquely simple way.

### Design

The P70 is a stackable valve system and can be supplied in combinations of 1 to 10 spool sections, additionally manifold sections can also be utilised to add further system flexibility. The valve is designed for system pressures of up to 320 bar.

The maximum recommended flow rates for the P70CF, CP and LS are 70, 90 and 90 l/min respectively, depending on how the valve is equipped. There are also a wide range of different available spools, enabling specific control characteristics to be optimised.

### Benefits

- Low fuel consumption and heat generation with low pressure drops.
- Productivity - our complete application adapted spool range will optimise each machine function to provide unsurpassed driver control and productivity.
- Precision - excellent repeatability especially during simultaneous operation by having machined land edges in the valve housing.

- Long service life – e.g. open spool ends with rubber bellows increase the service life of both spools and spool seals. Quality materials and high manufacturing precision ensure a superior product
- Smooth machine feel with less driver fatigue with low lever forces.
- Integrated functions – by combining P70 and flanged on manifolds additional functionality is effectively provided in the minimum space envelope and at the same time with reduced hosing complexity and cost.
- Flexibility – options allow for connection of more than one pump or valve in a system to increase the range of applications P70 can be used on.
- Security - P70 prevents undesirable load sinking during simultaneous operation with separate check valves positioned in each spool section.
- Safety - P70 gives an individual maximum pressure limitation with separate port relief valves positioned in each work port.
- Minimized downtime with simple design, which makes P70 easy to service. An emphasis on simplicity of design makes the P70 the best in class.

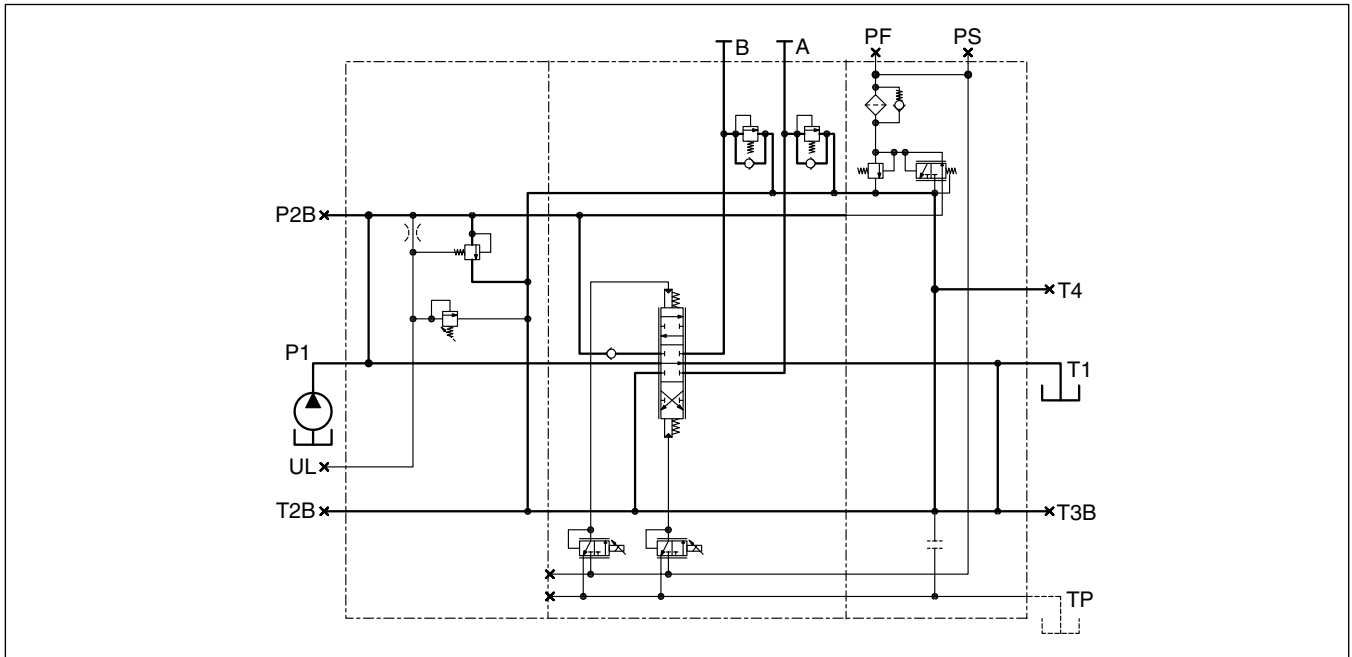

Principle circuit diagram for valve with open centre

**Open centre systems, OC**  
**(Valve with open centre, P70CF)**

The pump in a constant-flow system has fixed displacement, which means that the flow remains constant for a given engine speed. The pressure, however, changes to meet demand.

Any oil that is not directed out to a consumer flows back to tank via the free-flow gallery (open centre) in the valve. When several lifting functions are activated simultaneously, the pressure is determined by the heaviest load. Simultaneously operated functions should therefore have roughly the same pressure needs, or be divided into separate pump circuits to minimise cross-functional interference and give good operating economy. Provided that most of the pump capacity is used, the OC system is very economical. For this reason, it is important for the system to have a pump of the right capacity.

**Control characteristics**

In hand-operated valves, there is no clear-cut relationship between the stroke of the lever and the speed of the load. The speed of the load will depend on the following four variables: its weight, the pump flow, the direction of force and the direction of movement of any other simultaneously operated loads. The reason for this is that, when more passages are opened subsequently, the flows redistribute themselves so that the pressure drop in all flow paths becomes equal.

The P70CF's customised valve spools give considerably better simultaneous-operating characteristics. In some cases, this can result in higher energy losses during the fine-metering stage.

Our directional valves, which are designed to be remote controlled, are usually fitted with pressure compensated spools. This means that the regulated flow remains constant for a given lever stroke, regardless of any pressure variations within the system.

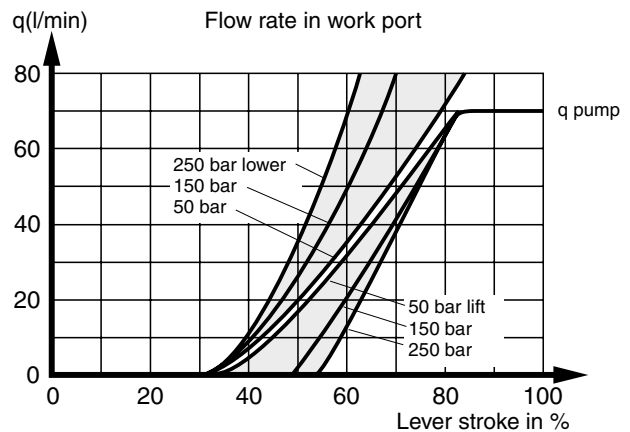

*In P70CF valves with hand-operated spools, speed is affected by the weight of the load, i.e. the heavier the lift load, the longer the lever stroke needed before the load starts to move. Conversely, the heavier the load to be lowered, the faster the lowering sequence.*

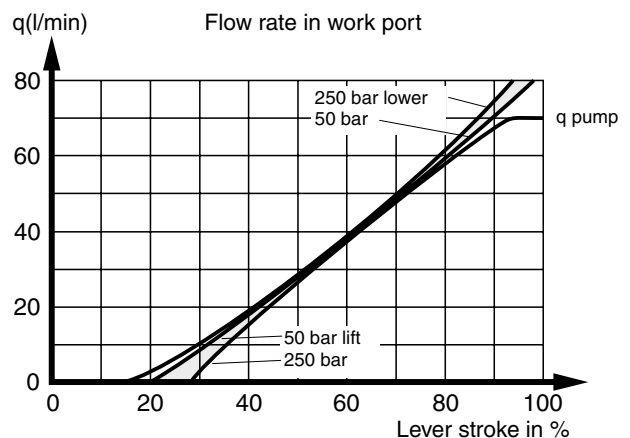

*In the P70CF equipped with FPC, PC, ECS and ECH closed spool-actuators, the spools are pressure compensated, with the result that the load's influence on speed is negligible.*

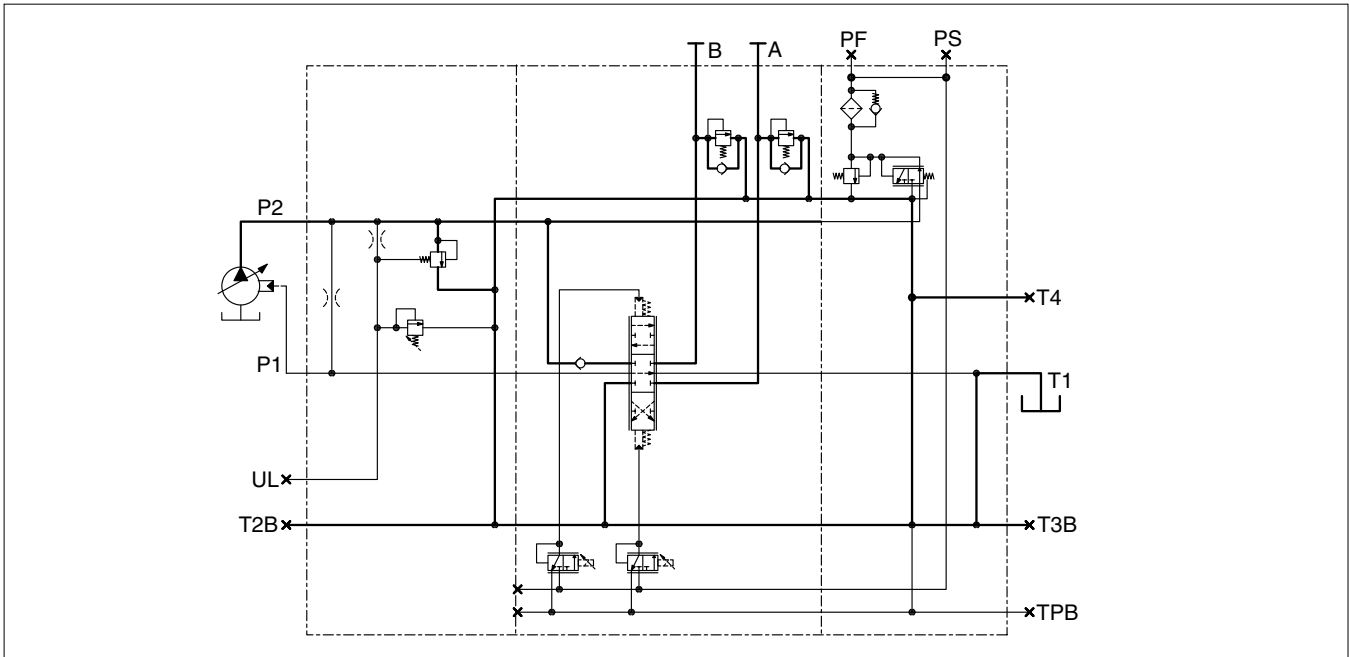

Principle circuit diagram for valve with closed centre

**Constant-pressure systems, CP, CPU**  
**(Valve with closed centre, P70CP)**

Constant pressure systems are supplied by a variable displacement pump. This type of pump is controlled by a regulator which ensures that the pressure is kept constant whilst the flow varies to suit the demand. The constant-pressure system is of relatively simple construction, with an uncomplicated valve. However, the variable pump is more advanced than pumps with fixed displacement.

To maintain the constant-pressure system's superior control characteristics, the pump must be dimensioned to give the sum of the maximum flows for simultaneously operated functions. If the pressure cannot be maintained, the valve loses its control characteristics quickly and the actuated functions start to influence each other, with the lightest loads receiving the most oil. However, this system is less susceptible to pressure drops, as the pressure corresponding to the machine capacity is always available.

There are two main types of pump on the market. What distinguishes them from each other is where the signal that influences the pump regulator comes from. One pump type takes the signal internally, whereas the other requires a signal from the directional valve. The P70CP can be used equally efficiently with either type.

**Control characteristics**

A correctly specified P70CP gives excellent control characteristics, with different functions having no affect upon each other. The system also has great anti cavitation characteristics which allow a lowering movement to change to a lifting one without delay. The maximum speed of each P70CP function is determined by the design of the spool and the pressure demands of the load. The P70CP can be fitted with a range of Parker's specifically designed spools, allowing them to be exactly suited to the customers speed and function requirements. In the P70CP too, remote controlled spools are pressure compensated. However, if the flow requirements of the system exceed the maximum capacity of the pump, the pressure level cannot be maintained and the normally very good control characteristics deteriorate.

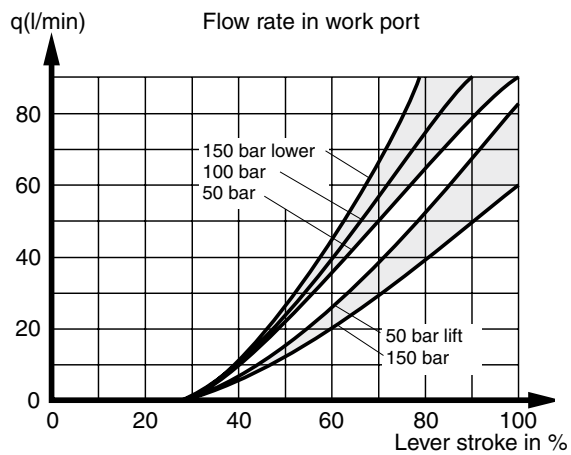

*In the P70CP with hand-operated spools, all loads start moving at the same point, regardless of the size and direction of the load. The size of the load does, however, affect the slope of the curve to some extent.*

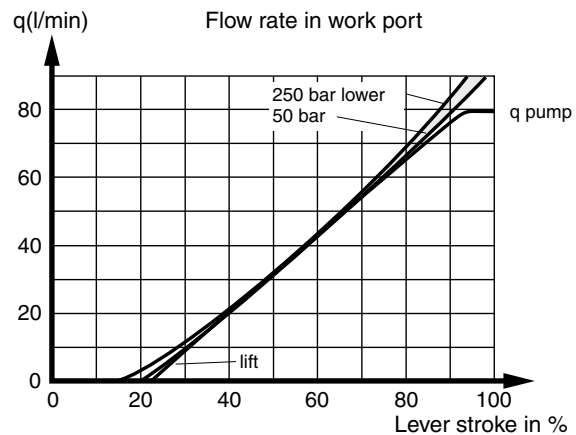

*In the P70CP equipped with FPC, PC, ECS and ECH closed spool-actuators, the spools are pressure compensated, with the result that the load's influence on speed is negligible.*

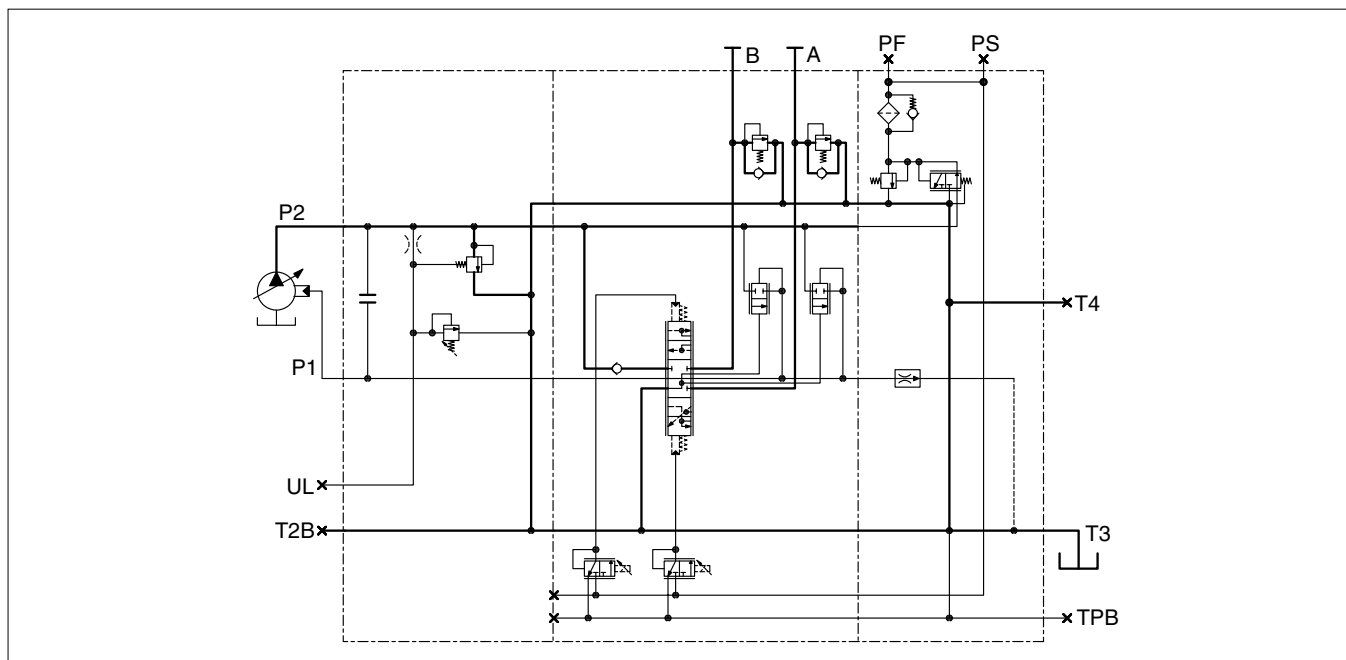

Principle circuit diagram for valve with load sensing

## Load sensing systems, LS (Valve with load sensing, P70LS)

In the load sensing system both pressure and flow are modulated to match immediate needs from the consumers, with a pressure level corresponding to the heaviest load at that moment.

When supplied from a variable displacement pump the directional control valve sends a load signal to the pump control regulator, which adjusts the pump output to maintain a constant pressure difference between the pump output and the load signal.

In the P70LS, the free flow gallery is used to collect the load pressures from all the motor ports of the valve. The signal of the highest load is then delivered to the variable pump regulator.

In order to achieve good operating characteristics, the pump should be sized to deliver flow equal to the sum of all simultaneously working functions. If the control pressure difference cannot be maintained, the operating characteristics of the valve can quickly deteriorate, and the controlled functions will influence each other, progressively resulting in lower loads receiving more flow than the higher ones.

In common with a constant flow system, simultaneously working functions should have approximately the same pressure requirement or they should be divided into separate circuits for high operating efficiency.

### Operating characteristics

With a correctly adjusted P70LS valve, the operating characteristics of the system are very good. The constant differential pressure maintained by the pump means that the flow to the heaviest load in a load sensing system is always pressure compensated.

However, load sensing does not mean that other functions are pressure compensated. To achieve good operating characteristics, the spools should be adapted for each function.

P70LS valves are designed for remote control and have pressure-compensated spools. This means that the regulated flow remains constant at a certain lever position, regardless of pressure variations in the system.

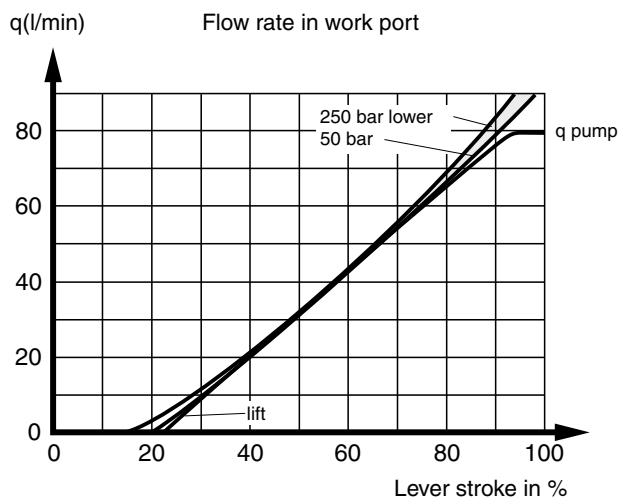

In the P70LS equipped with PC, ECS and ECH closed spool-actuators, the spools are pressure compensated, with the result that the load's influence on speed is negligible.

Below are a few examples of how the P70 can be connected up.

**A. Power beyond connection, multi-valve system, P70CF only**

The pump is connected to the first valve. Flow that is not directed to a consumer via the first valve continues to the next valve. The first valve therefore has priority, i.e. in the event of full spool actuation in the first valve, no flow continues to the next valve.

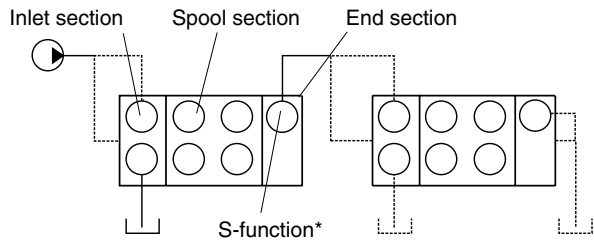

If an additional pump is connected to valve 2, then valve 2 receives the flow from pump 2 plus any residual flow from valve 1.

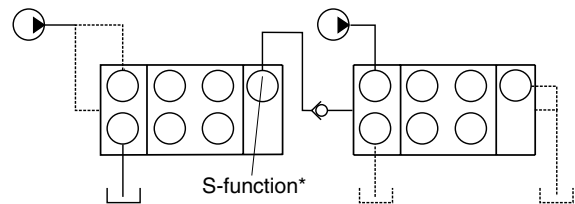

**B. Power beyond connection, single-valve system, P70CF only**

The pump is connected to the inlet section. Flow that is not directed out to consumers connected before the mid-inlet section continues to consumers connected after the mid-inlet section. This means that the first spool sections have priority, i.e. in the event of full spool actuation in a section before the mid-inlet section, no flow continues to the sections after the mid-inlet section.

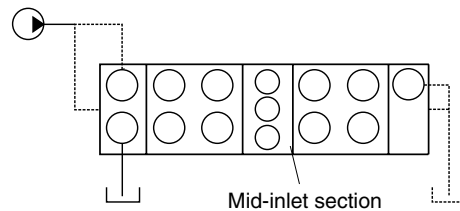

If an additional pump is connected to the mid-inlet section, then subsequent sections will receive the flow from pump 2 plus any flow from pump 1 that has not been used by the sections before the mid-inlet section.

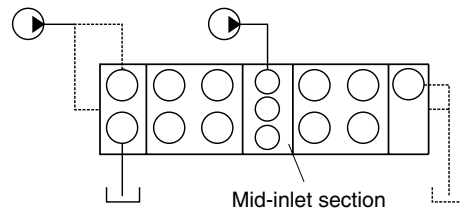

----- = Alternative connection

----- = Signal line

\* The different functions are described in more detail on pages 14 - 21.



**C. Parallel connection, multi-valve system**

In parallel connection, the same pump is connected to two or more valves. The function is the same as if the pump were connected to a single large valve.

Parallel connection, fixed pump (OC), P70CF

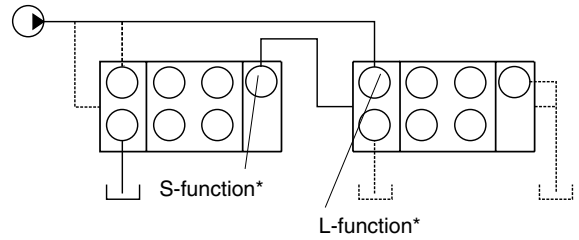

Parallel connection, variable pump (CP), P70CP

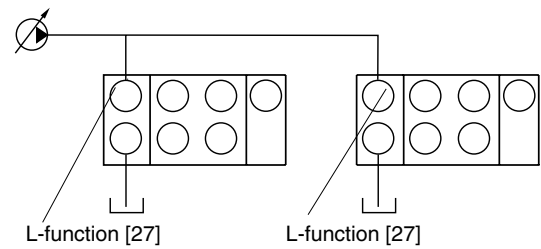

Parallel connection, variable pump (CPU, LS), P70CP, P70LS

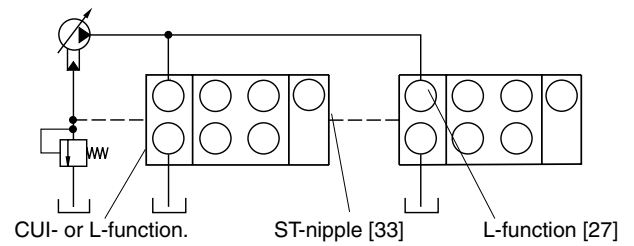

----- = Alternative connection

- - - - - = Signal line

\* The different functions are described in more detail on pages 14 -21.

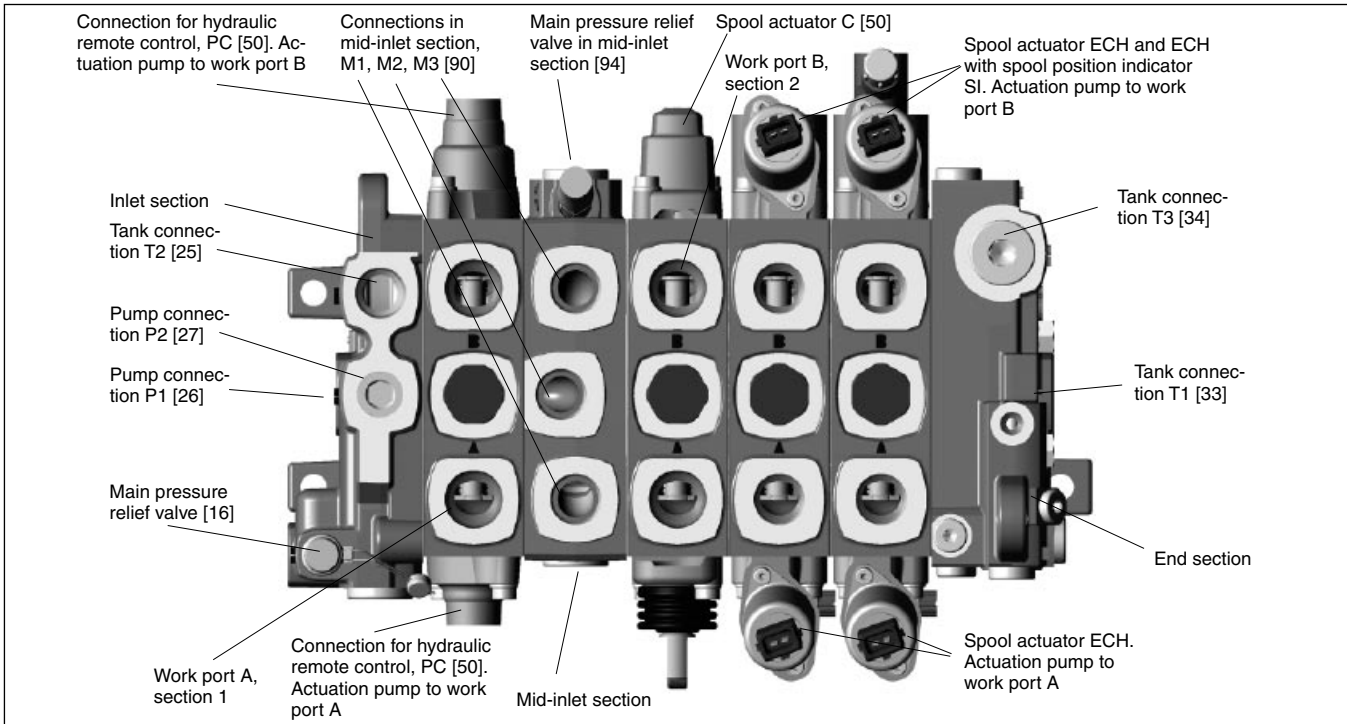

**Pressures**

Pump connection	max. 320 bar* (4640 psi)
Work ports	max. 350 bar* (5075 psi)
Tank connection, static	max. 10 bar (145 psi)

**Flow rates (recommended)**

P70CF. Pump connection	max. 70 l/min (18.5 USgpm)**
P70CP. Pump connection	max. 90 l/min (23.8 USgpm)**
P70LS. Pump connection	max. 90 l/min (23.8 USgpm)**
P70CF. Return fr. work port	max. 100 l/min (26.5 USgpm)**
P70CP. Return fr. work port	max. 125 l/min (33.0 USgpm)**
P70LS. Return fr. work port	max. 125 l/min (33.0 USgpm)**

**Internal pilot pressure**

Fixed setting	35 bar (508 psi)
---------------	------------------

**Leakage from work port over spool**

From A or B port: max. 75 cm<sup>3</sup>/min (4.58 cu.in/min) at 250 bar (3625 psi), oil temperature 50 °C (122 °F) and viscosity 30 mm<sup>2</sup>/s (cSt).

**Weight**

Since the weight will vary somewhat depending on the configuration of the valve, the values below are approximate.

**Valve housing inclusive of spool, pressure relief valve etc. and inclusive of spool actuator.**

Standard inlet section	2.7 kg (6.0 lb)
Inlet with bypass	4.9 kg (10.8 lb)
Single spool section C	3.5 kg (7.7 lb)
Double spool section C	7.2 kg (15.9 lb)
Single spool section ECH	4.1 kg (9.0 lb)
Double spool section ECH	8.4 kg (18.5 lb)
Mid-inlet section	2.7 kg (6.0 lb)
End section with pilot pressure supply	3.8 kg (8.4 lb)
End section	2.7 kg (6.0 lb)

**Connections**

Unless stated otherwise, all standard connections are available in two versions: G-version (BSP pipe thread) for flat seal (type Tredo) as per ISO 228/1 and UNF-version for O-ring seal as per SAE J1926/1.

Connection	Location	G-version	UNF-version
P1, P2	Inlet section	G1/2	7/8-14 UNF-2B
PX	Inlet section, IU	G1/4	9/16-18 UNF-2B
T2	Inlet section, I	G1/2	7/8-14 UNF-2B
T2	Inlet section, IU	G3/4	1-1/16-12 UN-2B
UL	Inlet section	G1/4	9/16-18 UNF-2B
M1, M2, M3	Mid-inlet	G1/2	7/8-14 UNF-2B
<b>Work ports</b>			
A and B	Spool section	G1/2	7/8-14 UNF-2B
PC	Spool section	G1/4	9/16-18 UNF-2B
T1, T3	End section	G1/2	7/8-14 UNF-2B
T4	End section	G1/4	9/16-18 UNF-2B
TP	End section	G1/4	9/16-18 UNF-2B
PS	End section	G1/4	9/16-18 UNF-2B
PF	End section	G1/4	9/16-18 UNF-2B male connector

**Surface treatment (painted) [07]**

The paint is only a primer. For full corrosion protection, the valve must be painted with an outer coat.

<b>X</b>	Unpainted
<b>P</b>	Primed valve, black. Primer only

\* Stated pressures are maximum absolute shock pressures at 10-bar tank pressure. See page 16.

\*\* Max. recommended flow rate dependent on choice of spool.

The valve can be mounted in all conceivable directions. However, the mounting base should be flat and stable so that the valve is not subjected to strain.

While the O-rings in the valve are normally of nitrile rubber, there are a number of special Viton variants. (Please contact Parker for further information.) Moreover, it is suggested that the P70CP is selected with the variant A002, which means that the O-rings between the parting surfaces will be manufactured from Viton. This variant is suggested as Viton withstands heat more comprehensively than nitrile rubber, and a constant pressure system working at near capacity will generate more heat than an open centre system.

**Temperature**

Oil temperature, working range +20 °C to 90 °C (68 to 194 °F)\*

**Filtration**

Filtration must be arranged so that Target Contamination Class 20/18/14 according to ISO 4406 is not exceeded. For the pilot circuit, Target Contamination Class 18/16/13 according to ISO 4406 must not be exceeded.

**Hydraulic fluids**

The best system performance is obtained using mineral-base oil of high quality and cleanness in the hydraulic system. Hydraulic fluids of type HLP (DIN 51524), oil for automatic gear-boxes Type A and engine oil type API CD can be used.

Viscosity, working range 15-380 mm<sup>2</sup>/s\*\*

**Technical information in this catalogue is applicable at an oil viscosity of 30 mm<sup>2</sup>/s and temperature of 50 °C (122 °F) using nitrile rubber seals.**

\* Product operating limits are broadly within the above range, but satisfactory operation within the specification may not be accomplished. Leakage and response will be affected when used at temperature extremes and it is up to the user to determine acceptability at these levels.

\*\* Performance efficiency will be reduced if outside the ideal values. These extreme conditions must be evaluated by the user to establish suitability of the products performance.

**Pressure drops**

Pressure drop with the pump-unloading inlet

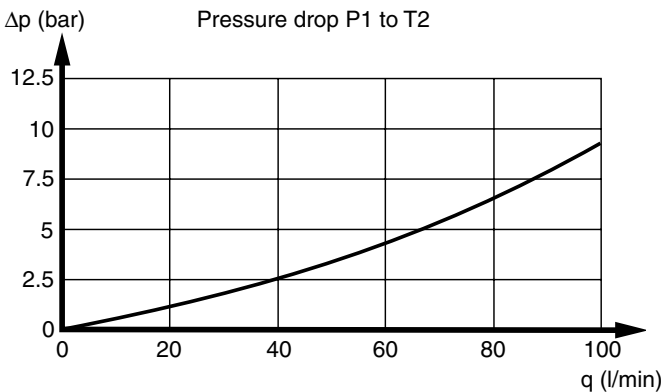

*Pump unloading function. See description and hydraulic circuit diagram on page 16.*

**Valve with standard inlet section and end section**

Δp (bar) Pressure drop P1 to T1

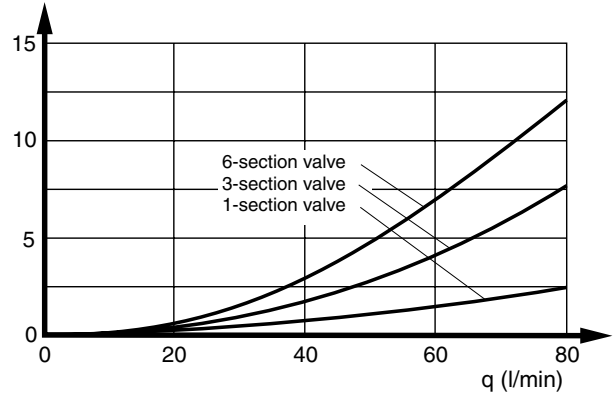

Δp (bar) Pressure drop P2 to T1

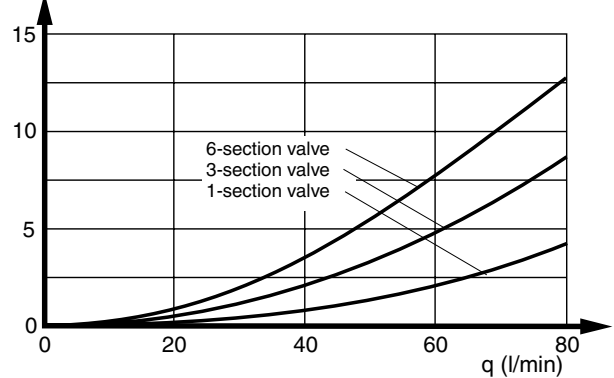

Δp (bar) Pressure drop P1/P2 to work port A or B

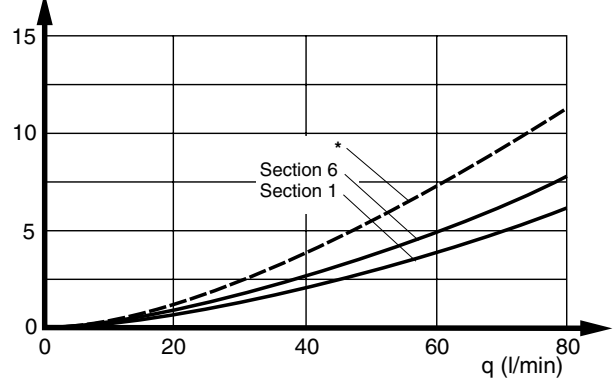

Δp (bar) Pressure drop, work port A or B to T1

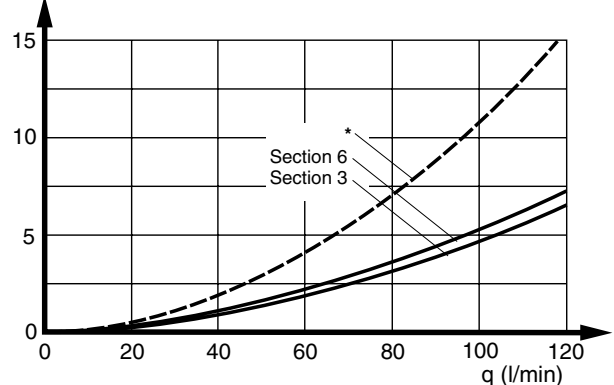

\* Broken line illustrates example of pressure drop in P70CF over a D-spool for q=65 l/min in section 6.

**Hydraulic circuit diagram showing basic functions, standard valve**

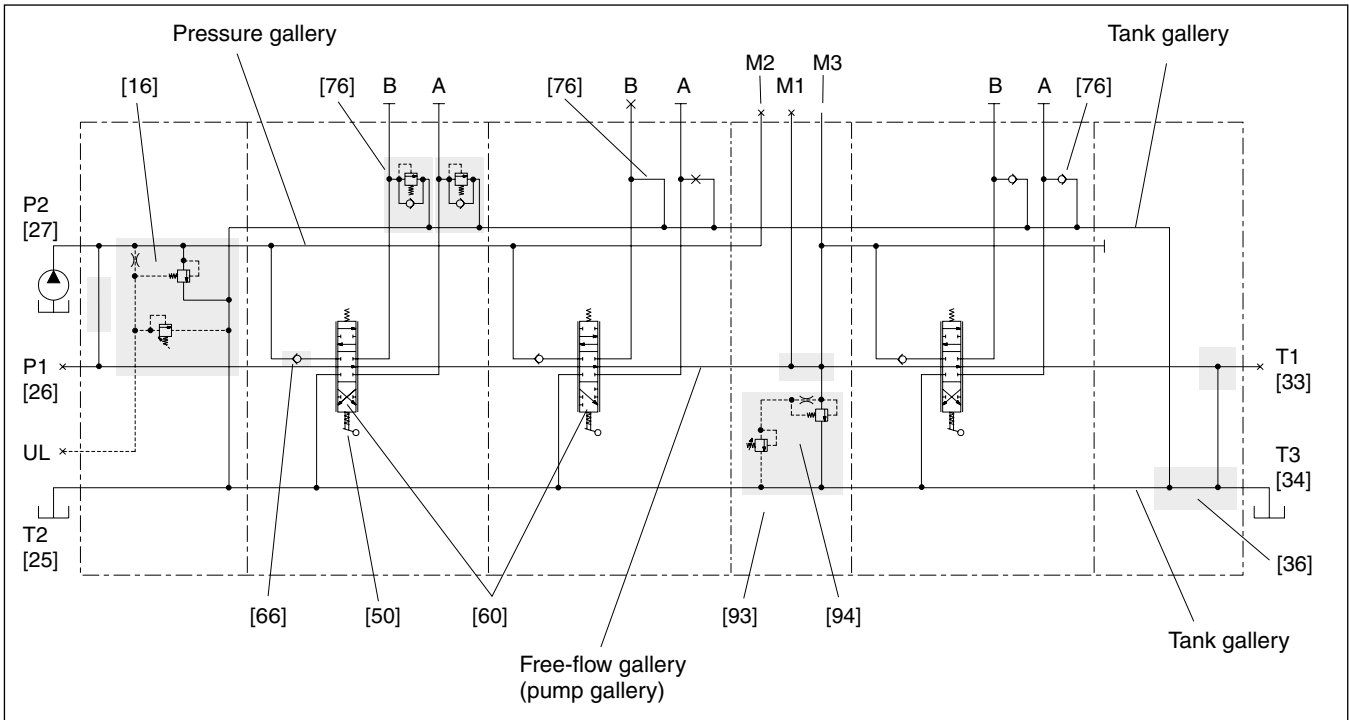

The circuit diagram above shows the P70CF with three spool sections and a mid-inlet between sections 2 and 3.

The shaded areas indicate functions or function groups that are described further on in the catalogue.

The item numbers in the hydraulic circuit diagram above and table below refer to function areas for which different options are available. The valve above is equipped as described below.

For details of other options available, for the P70CP and P70LS, please refer to the respective function areas [item numbers] given alongside the various sub-headings that begin on page 13.

Item No.	Code	Description	Item No.	Code	Description
16	PS	Adjustable main pressure relief valve in inlet.	66	N	Load-hold check valve in each section to prevent undesirable load sinking.
25	T2	Tank connection in inlet open.	76	PA	Combined port-relief and anti-cavitation valve in work ports A and B of sections 1.
26	P1B	Pump connection P1 in inlet plugged.		Y2	Connection between service-port A and tank gallery blocked in section 2.
27	P2	Pump connection P2 in inlet open.		X2	Connection between service-port B and tank gallery open in section 2 (always the case with EA spool).
33	T1B	Tank connection T1 in end section plugged.		N2	Anti-cavitation valves fitted in work ports A and B of section 3.
34	T3	Tank connection T3 in end section open.	93	C3	Mid-inlet with power beyond connection to give priority to preceding sections. Intended for single or multi-pump operation.
36	/	Free-flow gallery connected with tank.	94	PS	Adjustable main pressure relief valve in mid-inlet.
50	C	Spring-centred spool actuator on all sections for stepless operation by hand.			
60	D	Spool for double-acting function in sections 1 and 3.			
	EA	Spool for single-acting function working on work port A. Work port B blocked in section 2.			

**Hydraulic circuit diagram showing basic functions** (actuators with closed spool end)

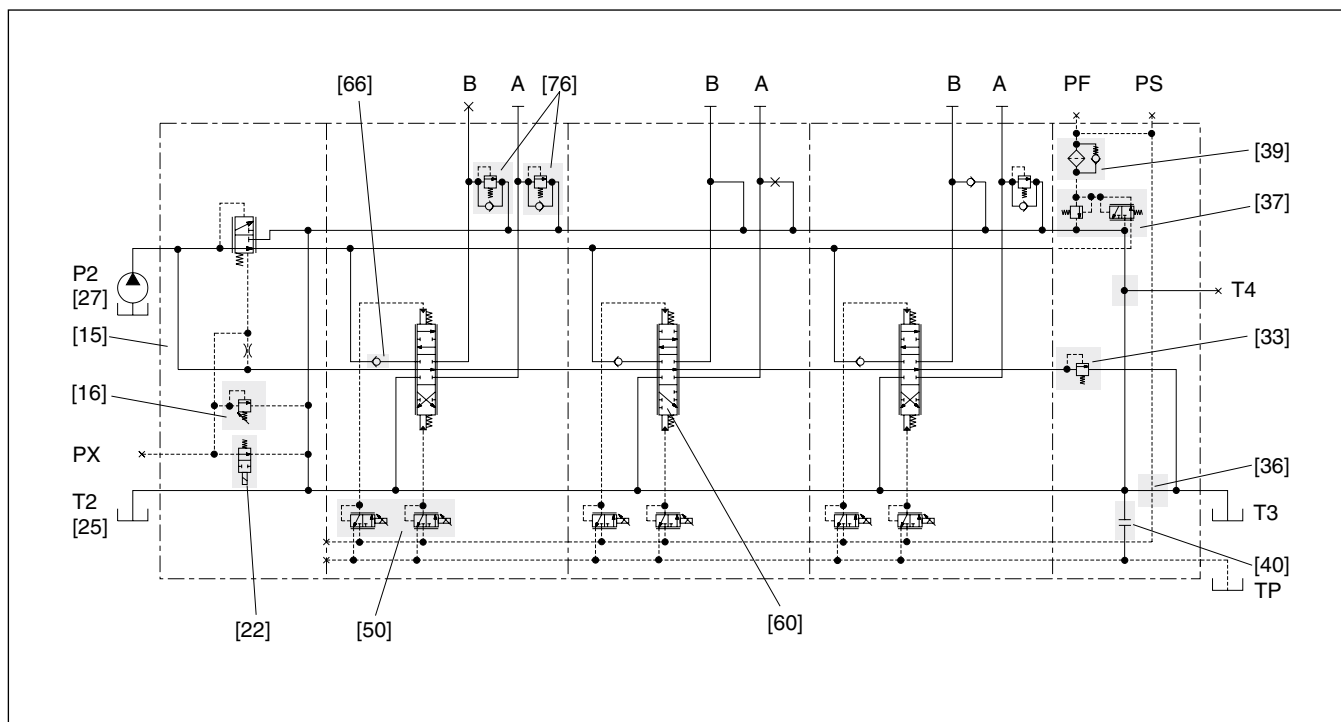

The circuit diagram above shows the P70 with three electro-hydraulically controlled spool sections and an integrated pilot-oil

supply. The shaded areas indicate functions or function groups that are described further on in the catalogue.

The item numbers in the hydraulic circuit diagram above and table below refer to function areas for which different options are available. The valve above is equipped as described below.

For details of other options available, for the P70CP and P70LS, please refer to the respective function areas [item numbers] given alongside the various sub-headings that begin overleaf.

Item No.	Code	Description
15	IU	Inlet with integrated bypass and pump-unloading function
16	PS	Adjustable main pressure relief valve in inlet.
22	BEN	Electric pump-unloading function.
25	T2	Tank connection in inlet open.
27	P2	Pump connection P2 in inlet open.
33	PT	Counter pressure function.
36	/	Free-flow gallery connected with tank.
37	R35	Reducing valve for pilot-oil supply.
39	S	Internal pilot-oil filter.
40	TP	Separate tank connection for pilot oil.
50	ECS	Spool actuator for electric remote control.

Item No.	Code	Description
60	D	Spool for double-acting function in sections 1 and 3.
	EA	Spool for single-acting function working on work port A. Work port B blocked in section 2.
66	N	Load-hold check valve in each section to prevent undesirable load sinking.
76	PA	Combined port-relief and anti-cavitation valve in work ports A and B of section 1 and work port A of section 3.
	Y2	Connection between service-port A and tank gallery blocked in section 2.
	X2	Connection between service-port B and tank gallery open in section 2 (always the case with EA spool).
	N2	Anti-cavitation valve fitted in work port B of section 3.

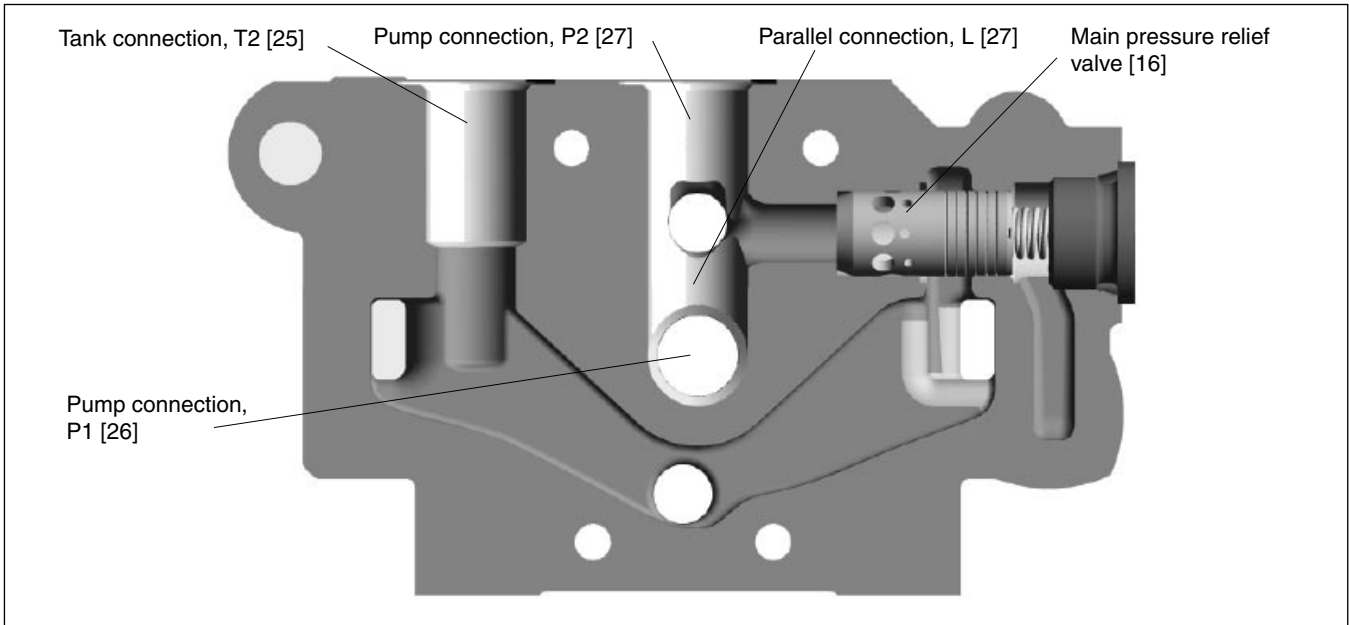

*Standard inlet section*

The inlet section comes in two basic versions: the standard version and a version with pump unloading.

The standard inlet section has two pump connections, P1 and P2, and a tank connection T2. The inlet section also contains the pilot-operated main pressure relief valve, in which either the UL connection for external pump unloading or the multi-level pressure relief function are located (see page 17).

The P70 with closed centre (P70CP) is created by combining inlet I with L or CUI at item [27]. P70LS shall always use the L option at item [27]. The difference between the P70CP and P70CF is that, in the P70CP, the open centre is used to break a hydraulic signal rather than to convey unused pump flow to tank. P70LS is using the open centre gallery for the load signal from the work port to the variable pump.

**Type of inlet section [15]**

- I** Standard inlet.
- IU** Inlet with integrated pump-unloading function (P70CF only).

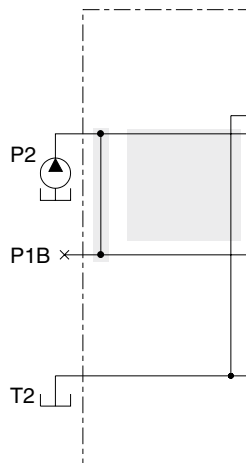

*Standard inlet I without main pressure relief valve (P70CF).*

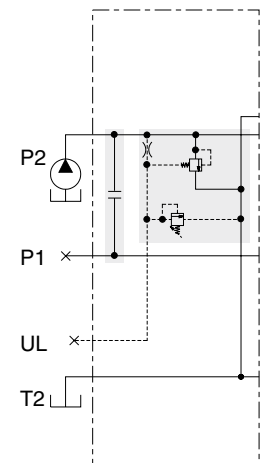

*Standard inlet I with L-function and main pressure-relief function PS (P70CP, P70LS).*

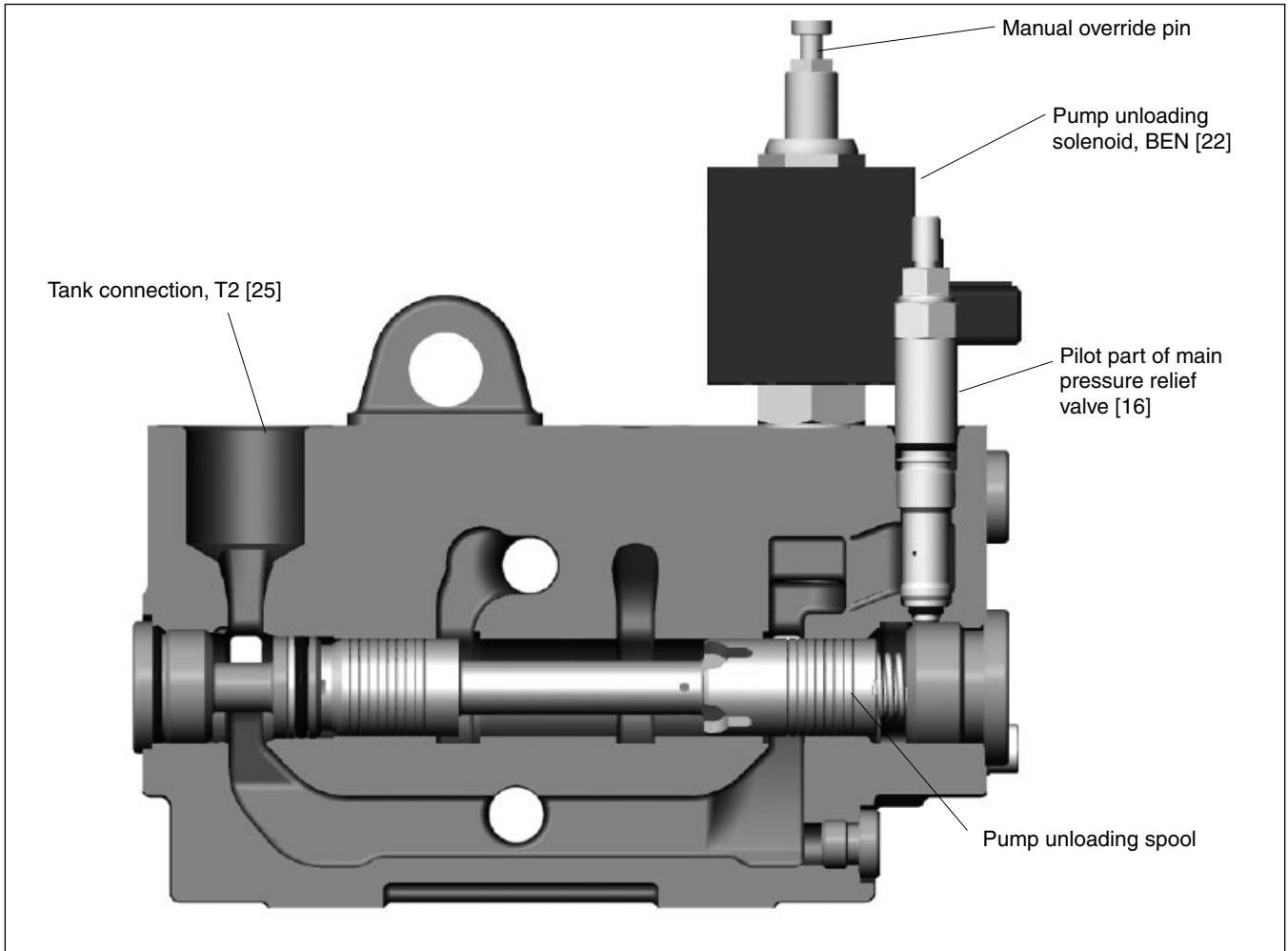

*Inlet section for valve with integrated pump unloading function.*

The inlet section, IU, includes a pump unloading function. This, together with some form of overcentre valve, enables the machine manufacturer to equip the machine with an emergency STOP function.

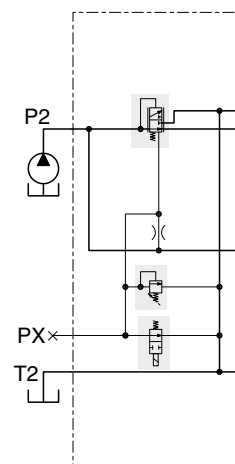

*Inlet section with pump unloading and pilot-operated main pressure relief valve.*

**Main pressure relief valve [16]**

The inlet section is equipped with an adjustable, pilot-operated pressure relief valve.

- PS** Adjustable main pressure relief valve. Pre-set at factory.
- PB** Adjustable main pressure relief valve. Supplied factory-set and sealed.
- /** Without pressure relief valve. Cavity not machined

**Pressure setting [17]**

Max. 320 bar. Settings above 320 bar can result in shorter service life. The permitted maximum pressure may be higher or lower depending on the type of application and the load spectrum. Please contact your nearest Parker representative for help and approval.

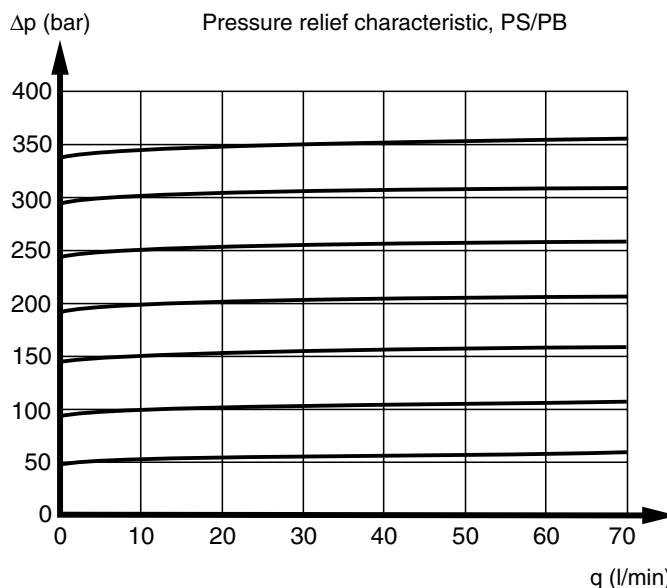

**Pump unloading [22]**

According to the EC Machinery Directive, machines must be equipped with one or more emergency STOP functions to enable actual or impending danger to be averted.

*“The emergency STOP function must stop the dangerous process as quickly as possible without creating additional hazards and the energy supply to the function must be cut off.”*

The pump-unloading inlet meets these criteria by diverting incoming oil from the pump directly to the tank line, at the same time blocking the pump line into the valve. This means that no energy is transmitted to the functions. It should be noted, however, that movements driven by dead weight will continue if there are no overcentre valves.

N.B. The pump-unloading function is a component of the machine safety system.

The pump-unloading function can also be used to save energy when the valve is not being used. By engaging the pump-unloading function when the valve is not being used, the pressure drop Pump-to-Tank falls. This function works just as well when downstream spool-sections are connected in parallel as well as in series.

The solenoid BEN [22] that controls the pump unloading function is available in 12 and 24 VDC versions. The solenoid is equipped with a manual activating device. For details on connectors, please see page 31.

- /** Inlet not equipped with pump unloading.
- BEN** Inlet equipped with electrically controlled pump unloading.
- BX** The inlet section is machined for the pump unloading function and plugged. This enables the pump unloading function to be installed at a later date, as well as the possibility of external control of pump unloading via port PX (see overleaf).

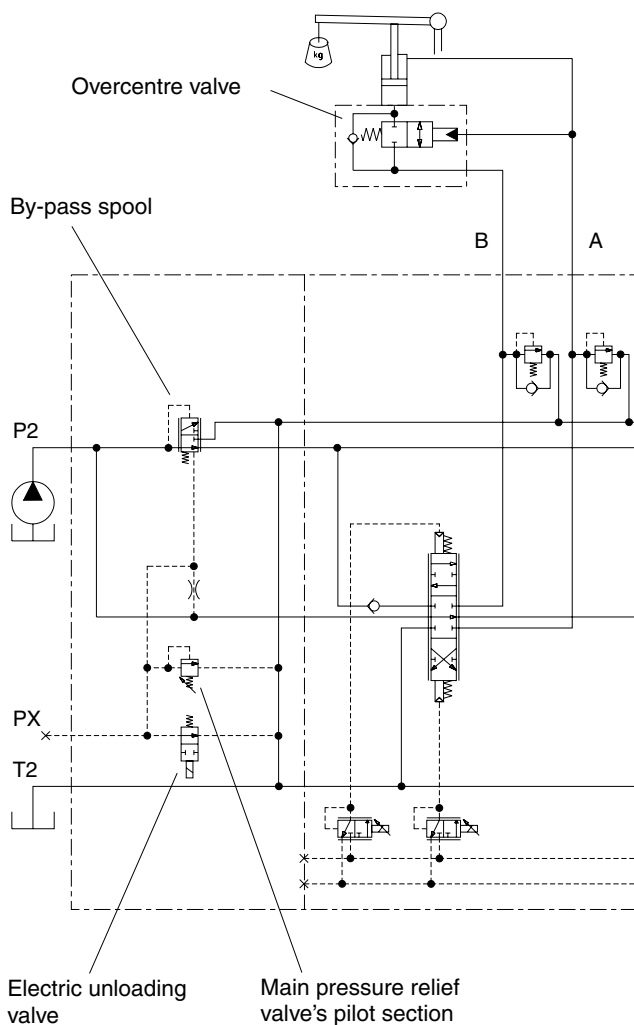

*Circuit diagram for pump unloading*



**External pump unloading or multi-level main pressure relief function**

Unloading can also be effected hydraulically by sending a hydraulic signal from connection UL or PX (depending on type of inlet [15] see pages 14 to 17) to external valves in an outer pilot circuit.

The unloading function can also be used to limit the maximum pressure for certain functions. In this way, high system pressures that arise when light loads bottom-out can be avoided.

By means of an external pilot-circuit connected to the pilot circuit (connection UL) of the main pressure relief valve, several pressure levels can be set as required. In this case, however, the external pilot valves must be set lower than the built-in one, and each must be connected to the pilot circuit by means of a two-way valve. The use of several different pressure levels will increase the service life of the system.

**Tank connection T2 [25]**

**T2** Tank connection T2 open.

**T2B** Tank connection T2 plugged.

**Pump connection P1 [26]**

Not present on inlet type IU [15].

**P1** Pump connection P1 open. Normal version.

**P1B** Pump connection P1 plugged.

**Pump connection P2 [27]**

See page 8 for more information about parallel connection.

**P2** Pump connection P2.

**P2B** Pump connection P2 plugged. Normal version.

**L** This option gives a parallel pump connection. This should be used in the P70CF when the actual valve is connected downstream of another valve. The function separates the free flow gallery from the pump gallery.

This option must be chosen when specifying a P70LS system.

This option is not available for inlet types IU in position [15].

**CUI** This option provides a pump connection with an unloading signal restrictor, for a variable pump. The pump pressure enters the free flow gallery via the CUI restrictor (Ø1.0 mm). The inlet section I [15] is connected with the pump regulator via the P1 connection. When all spools are in neutral, the flow coming from the pump gallery passes via the CUI restrictor to the tank connection in the valve's end section. The pressure that influences the pump regulator does not arise. As soon as a spool is shifted out of neutral, however, the connection from the CUI restrictor to tank is broken and the pump pressure is again directed to the pump regulator via the P1 connection.

This option should be used on the P70CP

This option is not available for inlet types IU in position [15].

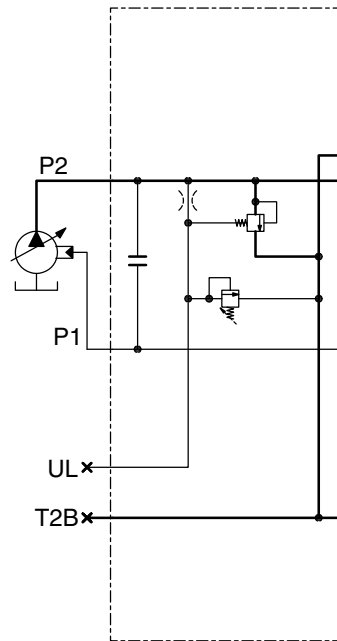

*Circuit for inlet section with L*

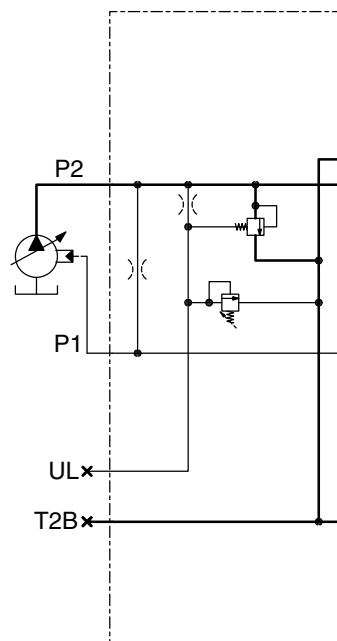

*Circuit for inlet section with CUI*

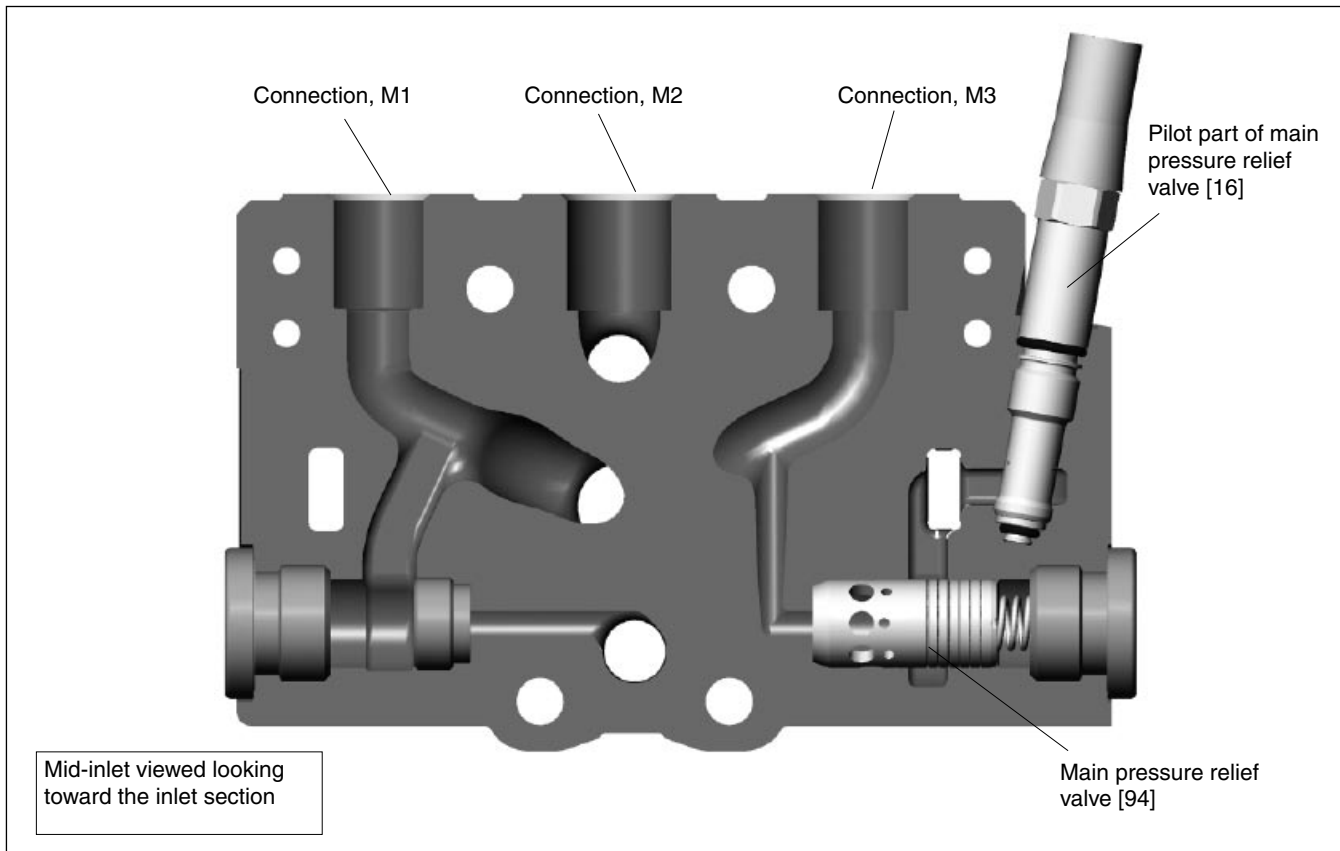

### Mid-inlet section [90]

Many compact system solutions can be obtained with the aid of a mid-inlet section, which contains three connections connected in different ways, depending on the choice of options.

The main pressure relief valve (see page 19) can/or should be fitted in the mid-inlet, depending on the way in which the system is constructed. See connection alternatives overleaf.

Several mid-inlets can be placed in one and the same valve to give optimum system construction.

**The mid-inlet section can only be selected for the P70CF.**

**Options, mid-inlet [93]**

- C3** Mid-inlet, with power beyond connection, that gives priority to the upstream sections. Flow which is not used in sections upstream of the mid inlet will be added to the incoming flow of the inlet M3. This option is intended for both single and multi pump operation.
- C5** Mid-inlet, without flow summation. Valves fitted with C5 function as two separate valves fitted with a common tank connection. If a separate tank connection is fitted to port M1, the pump to tank pressure will be reduced. This option is intended for multi pump operation only.
- C6** Mid-inlet with possibility of external power beyond connection via external check-valve between M1 and M3, with priority given to upstream sections, but without flow summation. Intended for multi-pump operation.

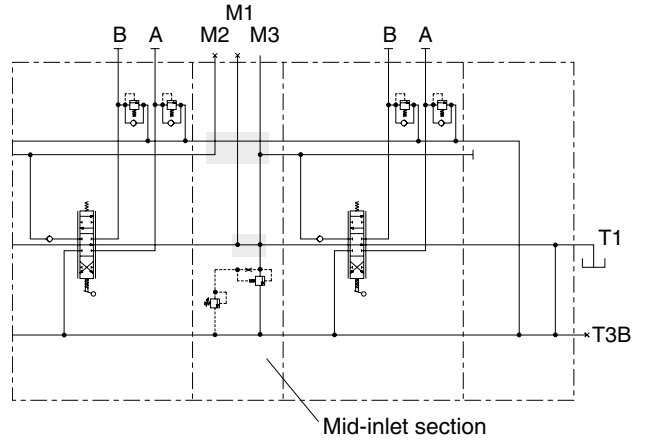

*Mid-inlet, C3. Used in multi-pump systems and when upstream sections are to have priority over flow delivered by the pump connected to the inlet section [15]*

**Main pressure relief valve [94]**

The mid-inlet can be fitted with the same main pressure relief valve as is fitted in the standard inlet. For further information and technical data, please see Inlet section [16] on page 16.

In systems in which several different pressure levels are required, main pressure relief valves can be fitted to give different pressure levels before and after the mid-inlet.

- PS** Adjustable main pressure relief valve. Delivered with opening pressure pre-set as per specification.
- PB** Adjustable main pressure relief valve. Delivered pre-set and factory-sealed.
- Y** Without pressure relief valve.

**Pressure setting [98]**

Max. 320 bar. Settings above 320 bar can result in shorter service life. The permitted maximum pressure may be higher or lower depending on the type of application and the load spectrum. Please contact your nearest Parker representative for help and approval.

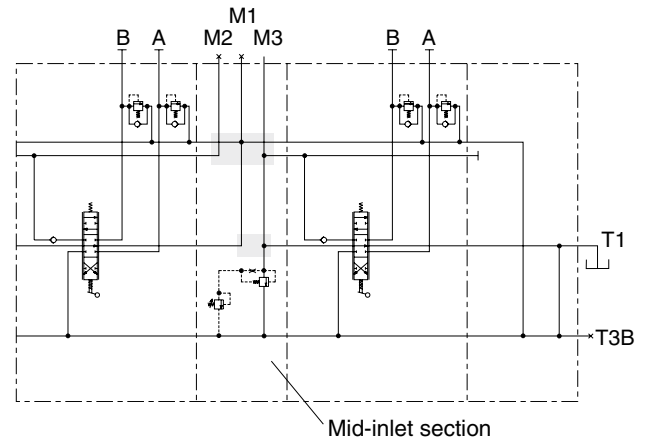

*Mid-inlet, C5. Used in multi-pump systems. Valve functions as two separate valves, but with common tank gallery.*

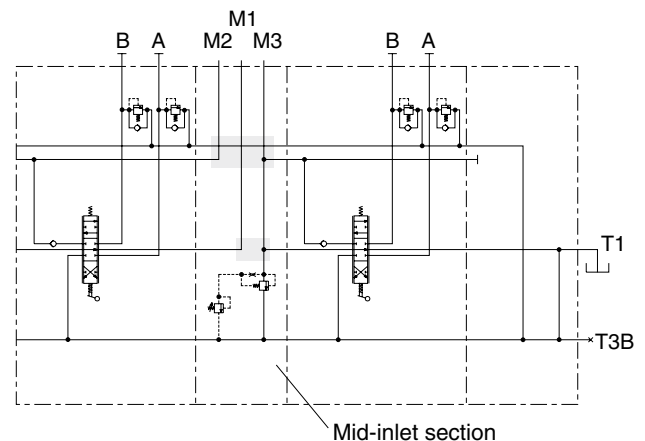

*Mid-inlet, C6. Used for separate feeding (port M2) of non-prioritised sections upstream of the mid-inlet. See page 22.*

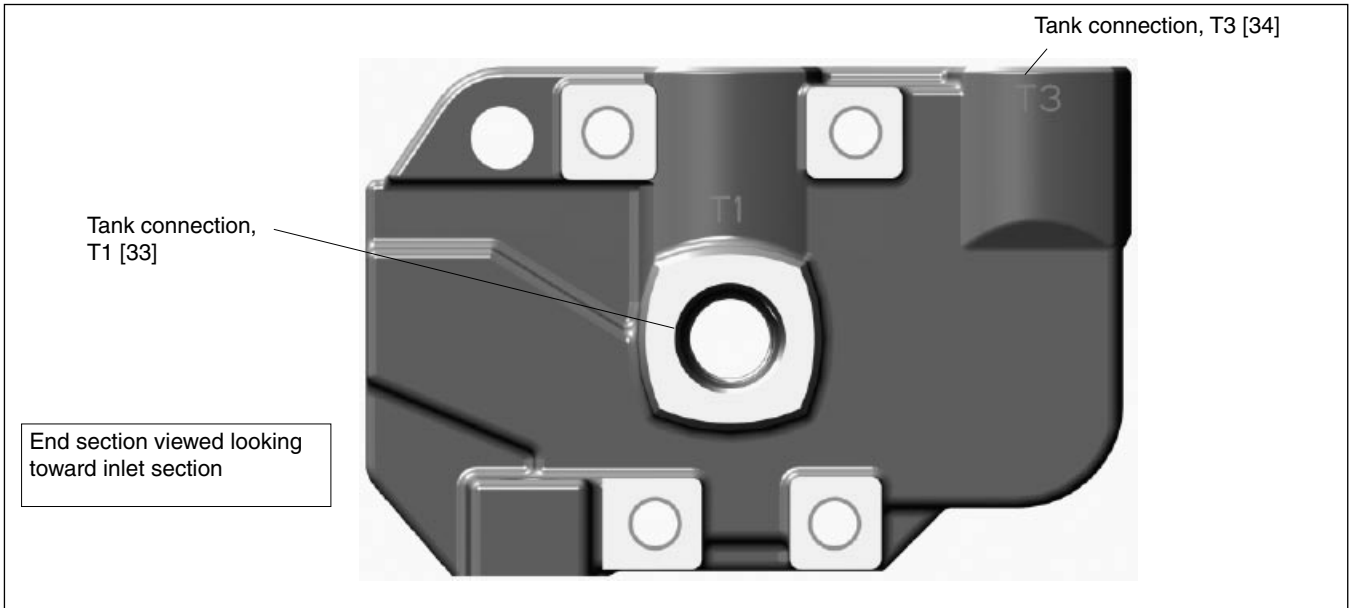

*End section for standard valve*

The end section is available in two different versions, the standard version and one with an integrated pilot-pressure supply. The standard end-section is equipped with two tank connections, T1 and T3. A series-connection function can be fitted in T3 to feed downstream valves. See page 8. For valves with integrated spool-actuators, the end section includes a pressure-reducing valve for the pilot-pressure supply, as well as a tank connection T4.

**Type of end section [30]**

- US** Standard end-section.
- USP** End section with pilot-pressure generation.

**Tank connection T1 [33]**

- T1** Tank connection T1 open (normal version).
- T1B** Tank connection T1 plugged.
- PT** Counter pressure valve that raises pressure to 5 bar in free-flow gallery to ensure that the minimum requisite pilot-pressure is maintained (USP only).
- PT8** Counter pressure valve that raises pressure to 8 bar in free-flow gallery to ensure that the minimum requisite pilot-pressure is maintained (USP only).
- LD** This is a tank connection with a drain cartridge fitted. This must be used in the P70LS.

**Tank connection T3 [34]**

- T3** Tank connection T3 open.
- T3B** Tank connection T3 plugged.

**Series-connection function [36]**

- /** Without power beyond connection.
- S** Series-connection function used to block connection between free-flow gallery and tank. Flow in free-flow gallery fed to subsequent valve through either T1 or T3 connection. Tank connection T2 in the inlet must be open.

**Spool section      Standard end-section**

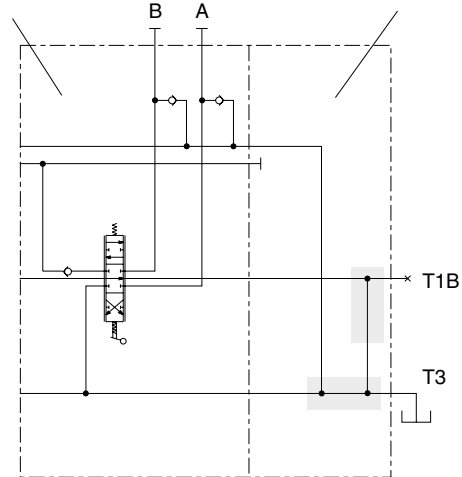

*Tank connection T3 open. Free-flow gallery connected with tank gallery in the end section.*

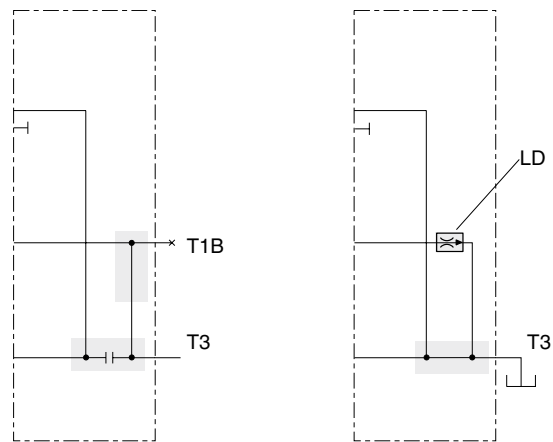

*End section equipped with S-function. The free-flow gallery's connection with the tank gallery is blocked.*

*Tank connection T3 open. Open centre gallery connected with tank through LD at item [33]. P70LS only.*

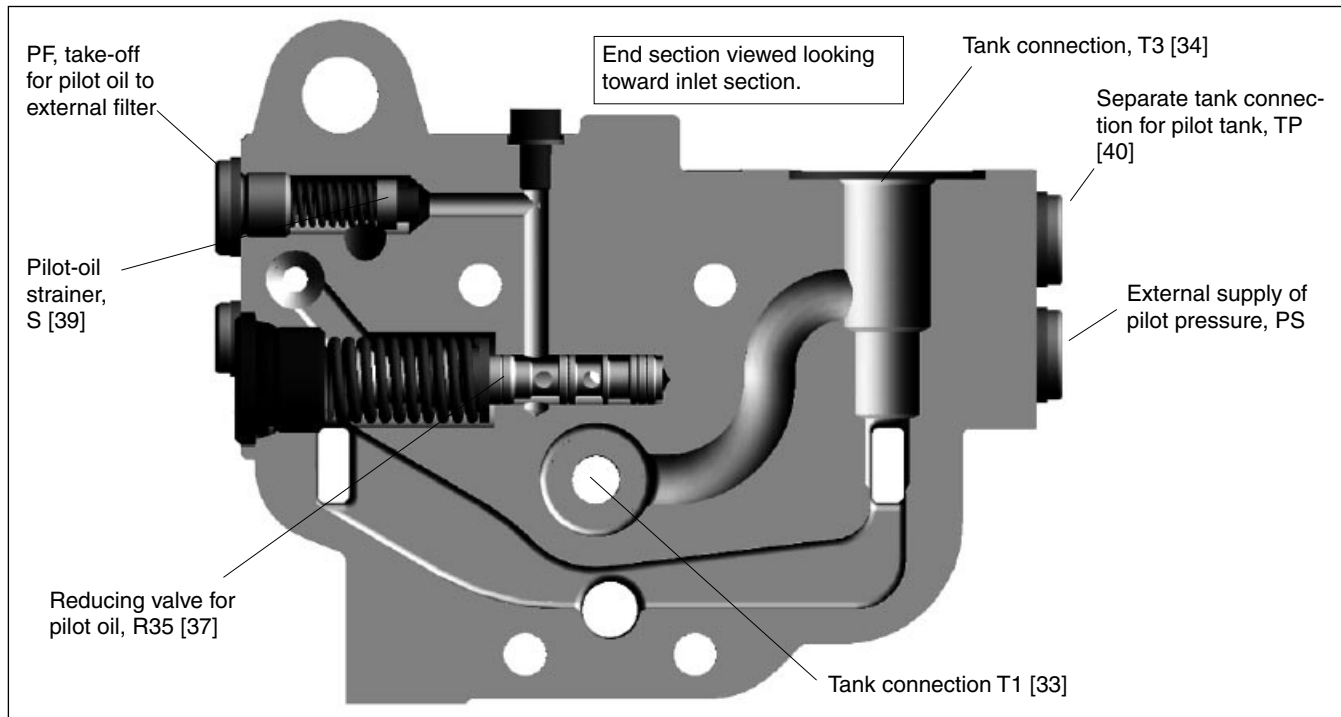

End section with integral pilot-oil supply

**Reducing valve [37]**

Internal pilot-pressure supply is a valve function built into the end section, which acts both as a reducing valve and a pressure relief valve in the pilot circuit. For safety reasons, it is furnished with a separate safety valve function that prevents the maximum permissible reduced pressure from being exceeded.

A pilot pressure for external use, e.g. for the PCL4 remote-control valve, can be tapped via the PS connection.

/ Without reducing valve

**R35** Reducing valve set at 35 bar.

**Pilot-oil strainer [39]**

**S** Coarse filter with by-pass function in the internal pilot-pressure supply. Filter protects pilot circuit from dirt, especially during start-up of system.

**YS** Adaptor for connection of external pilot-pressure filter. Enables pilot circuit to be supplied with cleaner oil compared with the rest of the system (recommended).

**Separate tank connection for pilot circuit [40]**

**TP** Separate tank connection for pilot circuit is open. The connection to the main tank gallery in the directional valve is blocked. This function is suitable for systems in which there is a risk of dynamic pressure variations in the tank line causing variations in the pilot circuit when there is a common tank line.

**TPB** This end section has a separate tank connection for the pilot circuit, which is machined and plugged. The pilot circuit's return to tank is connected to the valve tank gallery.

**TPC** The pilot circuit's tank gallery is connected to the main tank gallery via a check valve. The check valve is used to prevent pressure peaks reaching the spool actuators.

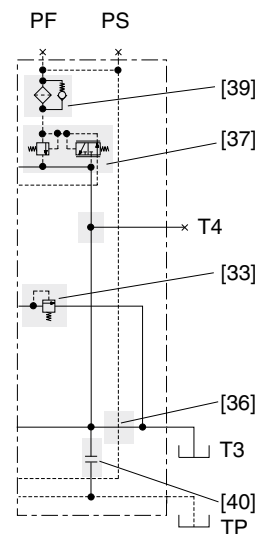

Tank connection T3 open. Free-flow gallery connected with tank via counter pressure function, PT [33].

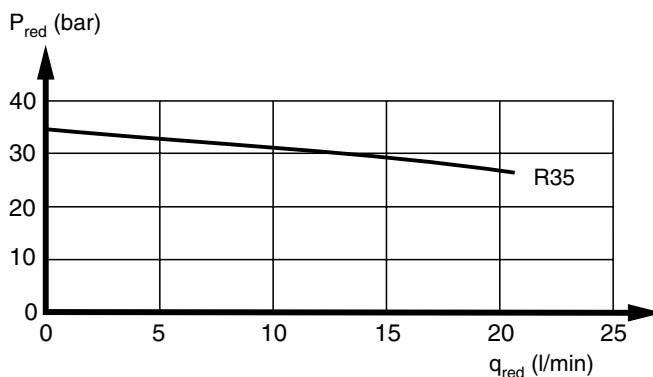

P<sub>red</sub> = reduced pressure  
 q<sub>red</sub> = take-off flow from reducing valve

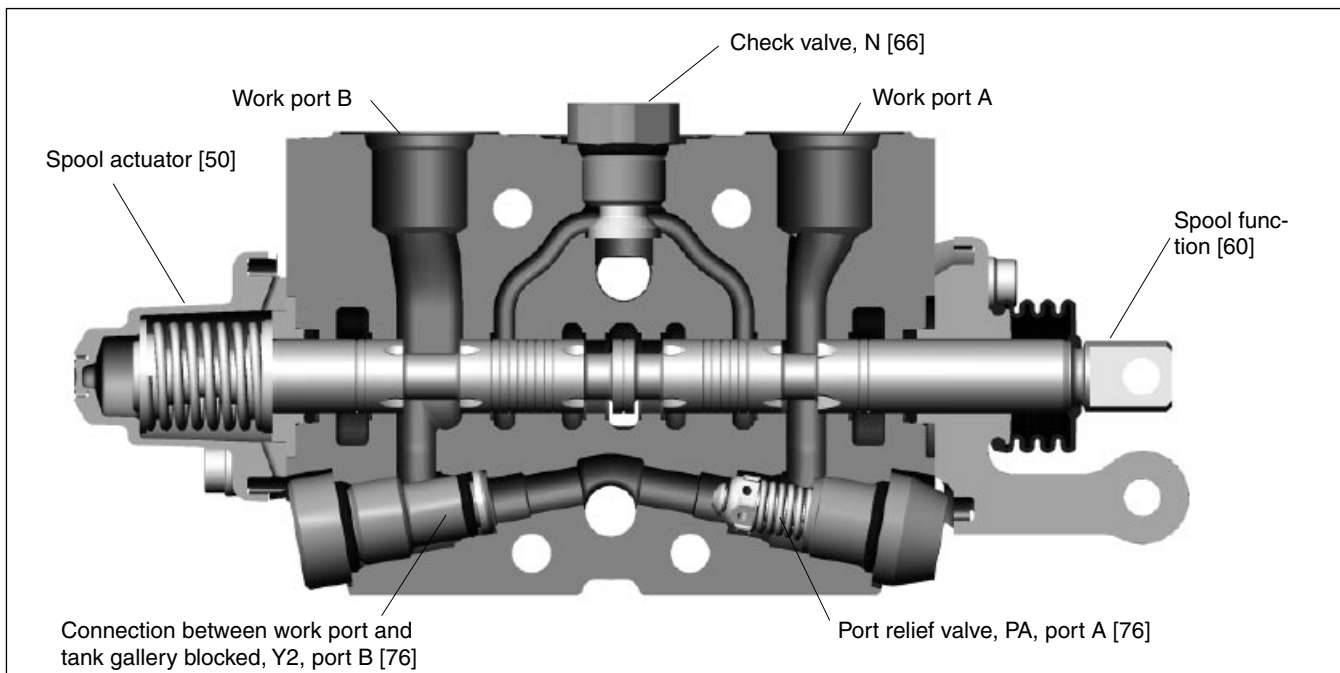

*Spool section, P, with open spool end.*

The P70 is stackable and can be supplied in combinations of 1 to 10 spool sections. For each spool section, there is a wide range of spools and spool actuators to choose between. This enables optimal adaptation of individual spool sections to suit the application and control function. The spool sections have machined control edges for precise control characteristics.

**Type of spool section [47]**

**P** Parallel-connected section

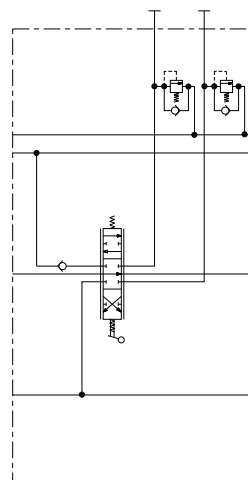

*Parallel-connected section.*

**Lever bracket [51]**

**LMA** Lever bracket for open spool end. Lever itself not included. Must be ordered separately (see page 32).

**LMB** Lever bracket for open spool end. Lever itself not included. Must be ordered separately (see page 32).

**LU** No lever bracket – open spool end.

\* Spool in (←) gives actuation P-A, B-T.  
 Spool out (→) gives actuation P-B, A-T.

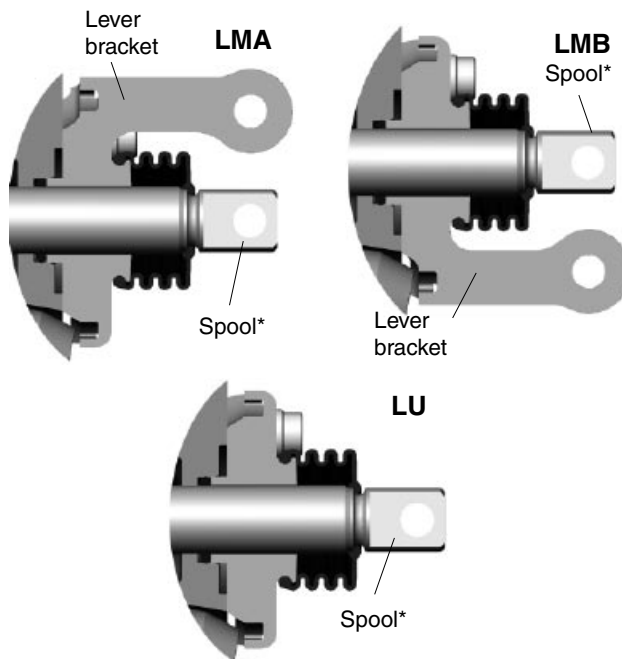

**MJA** Lever bracket and link parts for mechanical joystick, type A, and for open spool end. Lever bracket MJA have always to be selected in the left section and lever bracket MJ in the right section. Lever itself not included. Must be ordered separately (see page 33).

**MJA**

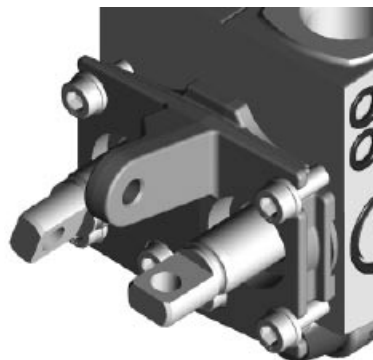

**MJB** Lever bracket and link parts for mechanical joystick, type B, and for open spool end. Lever bracket MJB have always to be selected in the left section and lever bracket MJ in the right section. Lever itself not included. Must be ordered separately (see page 33).

**MJB**

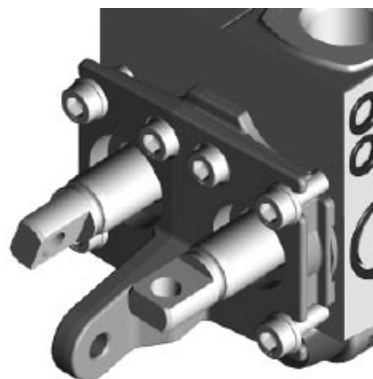

**MJA complete**

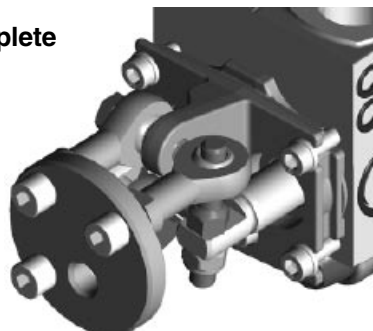

**Spool actuators [50]**

A large number of spool actuators is available for the P70CF. They are divided into three different groups: hand-operated, ON/OFF remote controlled and proportionally remote controlled.

**Hand-operated spool actuators with open spool end**

- C/C140** Spring-centered spool actuator. Actuator for stepless control with spring centering to neutral position. C140 has stronger centering force. Recommended when cable control or mechanical linkages are used.
- B2C** Three-position, spring-centered spool actuator. The B2C has mechanical detents at the two end positions, so that the spool stays in place when fully actuated in either direction. It must be shifted out of the respective end positions manually.
- CB** Float-position spool actuator. The CB is a special actuator for F-spools (see page 29). It features stepless operation, with spring centering from the two end positions to neutral. It also has a fourth position with a mechanical detent. The spool must be shifted out of the fourth position manually.

**Remote controlled spool actuators with open spool end and possibility of manual control**

**ACE** An electro-pneumatic ON/OFF control with spring centering and the possibility of stepless operation by means of a lever.

Primary air:	4 – 10 bar
Control current:	12 VDC min. 0.85 A 24 VDC min. 0.42 A
Voltage tolerance:	± 20%

The spool actuator has a common pressure gallery for primary air. The primary air can be connected to either the first or the last valve section directly by means of a plug-in connector for Ø6 mm air hose.

**ACP** A pneumatic proportional spool actuator with spring centering and the possibility of stepless operation by means of a lever. The ACP is best controlled by the Parker VP04 remote control valve.

Breakaway pressure:*	2 bar
Final pressure:*	7 bar
Permissible air pressure in pilot cap	Max. 10 bar
Connections:	G1/8 or NPTF 1/8-27

\* The breakaway pressure refers to the pressure needed for the directional valve to open the connection "pump to work port". The final pressure is the lowest pressure needed to effect full actuation of a spool in the directional valve. The foregoing data must be taken into consideration when choosing control units, since the opening pressure of the control unit must be lower than the breakaway pressure of the spool actuator in order to avoid jerky starting and stopping. However, the control unit's final pressure must be higher than the final pressure of the directional valve in order to ensure that the spools can be fully actuated. This is important for the P70CF because, if the spool is not actuated fully, the free-flow gallery will not close, with the result that a certain amount of flow will go directly to tank.

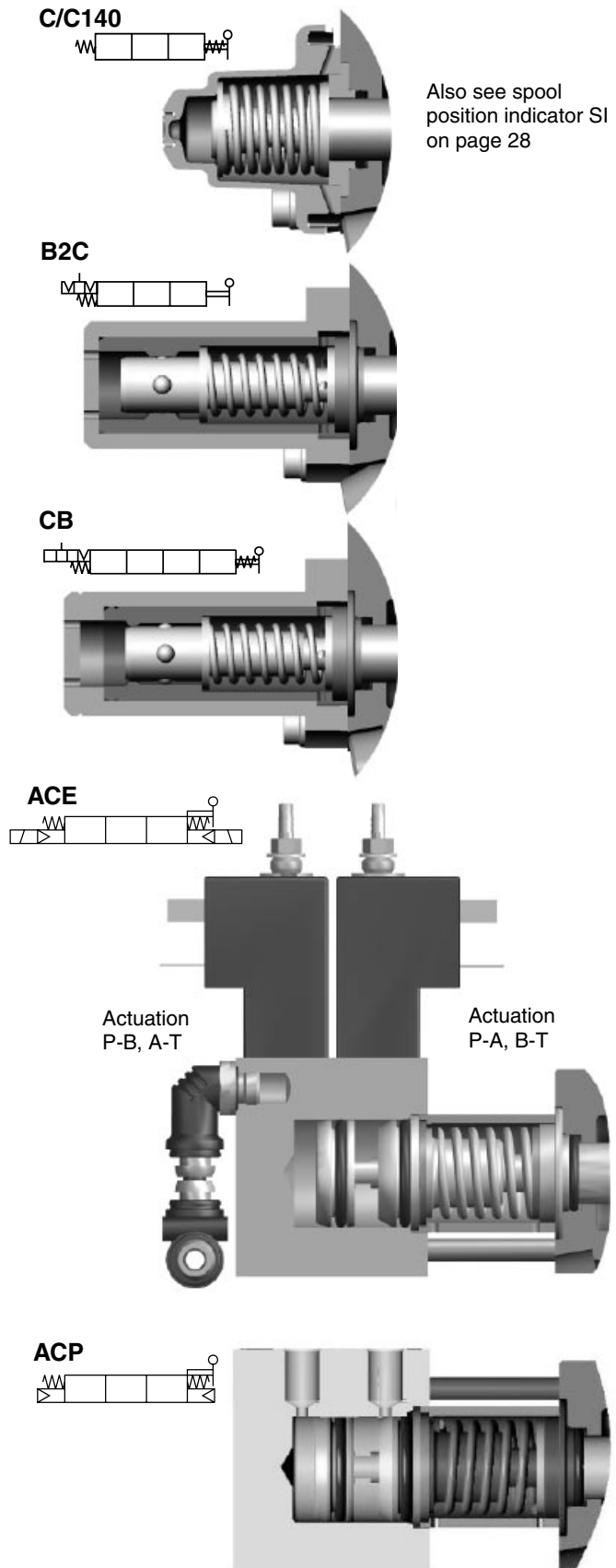



**Remote controlled proportional spool actuators with closed spool end**

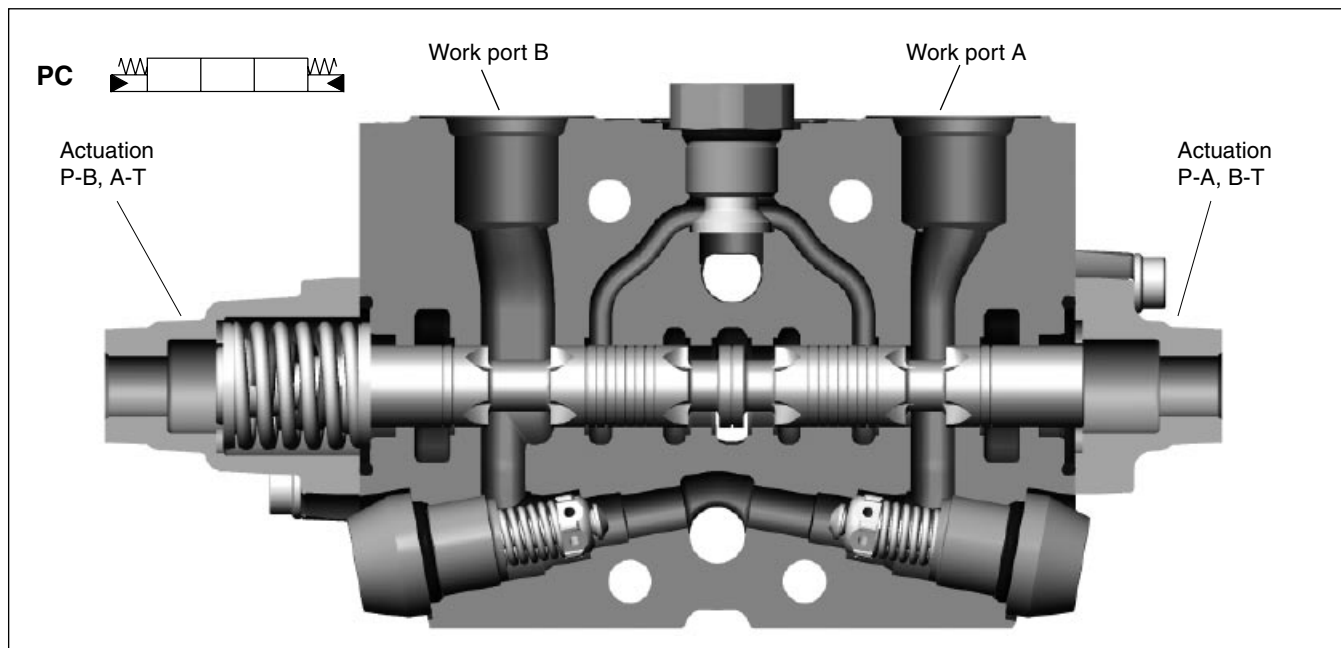

**PC** Hydraulic, proportionally controlled, spring-centred spool actuator. Best controlled by PCL4 remote control valve (see separate brochure).

Breakaway pressure:\* 6 bar  
 Final pressure:\* 17 bar  
 (max. 35 bar)

Connection thread: G1/4 or 9/16-18 UNF

**FPC** Hydraulic, proportionally controlled, spring-centered spool actuator with a fourth position for shifting the spool into the float position.

**Valves with FPC have to be feeded with external pilot pressure in open centre systems (Not in CP/LS).**

Breakaway pressure:\* 6 bar  
 Final pressure:\* 16 bar  
 (max. 18 bar)

Pressure for float position: min. 24 bar  
 (max. 35 bar)

Connection thread: G1/4 or 9/16-18 UNF

\* The breakaway pressure refers to the pressure needed for the directional valve to open the connection “pump to work port”. The final pressure is the lowest pressure needed to effect full actuation of a spool in the directional valve. With the FPC spool actuator, the float position is obtained by further increasing the final pressure from max. 18 bar to min. 24 bar. The foregoing data must be taken into consideration when choosing control units, since the opening pressure of the control unit must be lower than the breakaway pressure of the spool actuator in order to avoid jerky starting and stopping. However, the control unit’s final pressure must be higher than the final pressure of the directional valve in order to ensure that the spools can be fully actuated. This is important for the P70CF because, if the spool is not actuated fully, the free-flow gallery will not close, with the result that a certain amount of flow will go directly to tank.

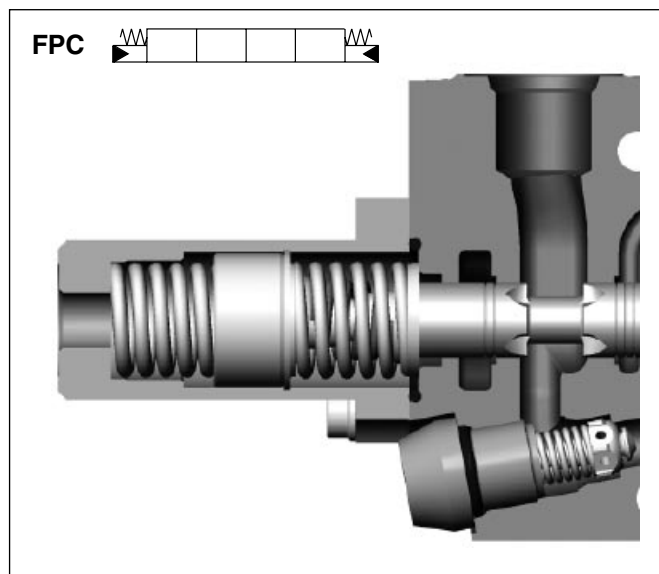

**Remote controlled proportional spool actuators with closed spool end and possibility of manual operation**

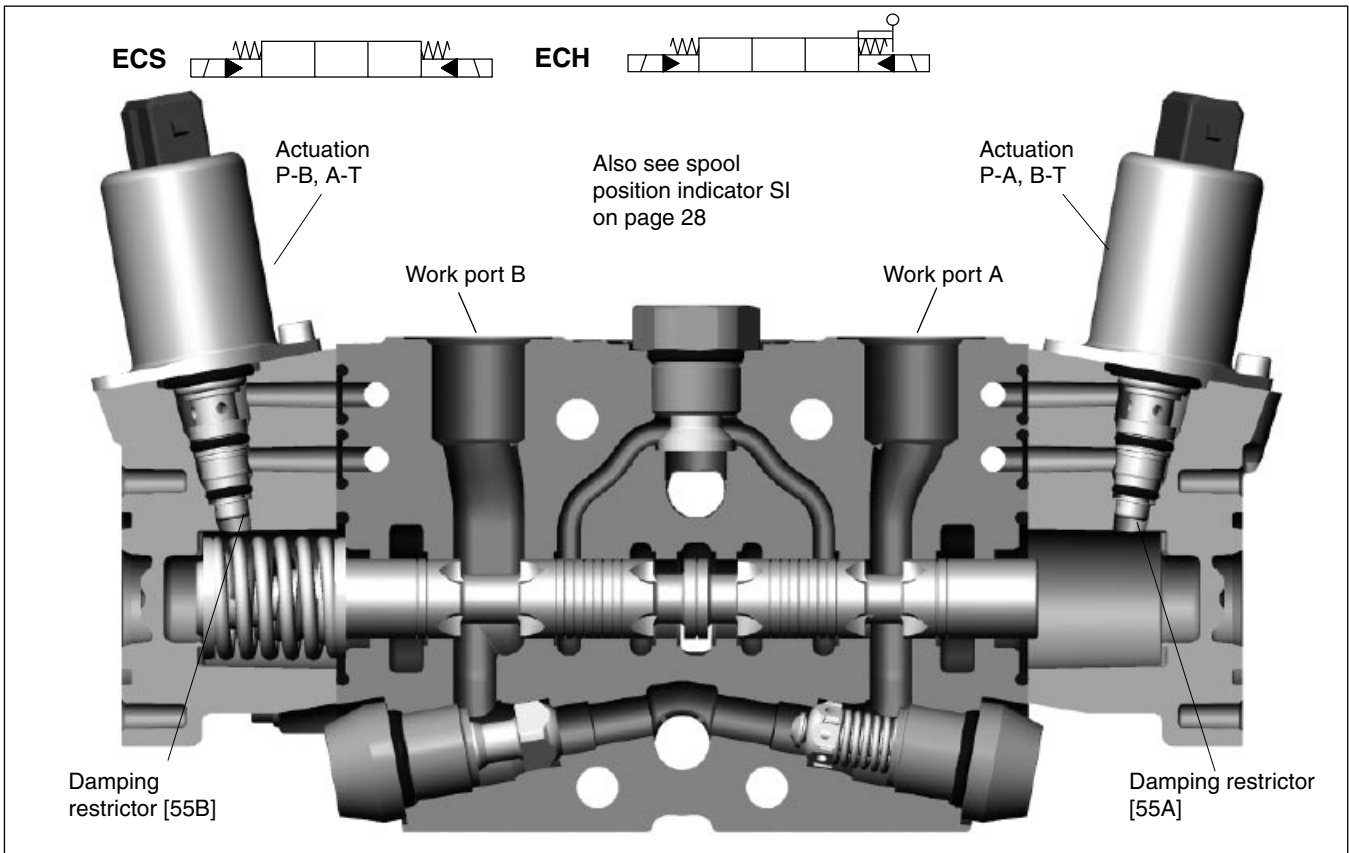

**ECS** Electro-hydraulic proportional spool actuator

The ECS is an electro-hydraulically, proportionally controlled, spring-centred spool actuator. The PS25 cartridge valve is used as its remote control valve.

The ECS spool actuator is best controlled by means of a Parker electric remote-control system (see separate brochure). The electrical connector must be ordered separately (see page 31).

Voltage	<b>12 V</b>	<b>24 V</b>
Breakaway current:*	max. 500 mA	max. 260 mA
Final current:*	min. 1010 mA	min. 510 mA
Solenoid (PS25):	max. 1450 mA 100% ED	max. 730 mA 100% ED

Coil resistance at +20 °C:	5.4 Ω	21.7 Ω
Inductance:	27.7 mH	7.0 mH
Tank pressure:	max. 15 bar	max. 15 bar

**ECH** As above, but with possibility of stepless operation by means of a hand lever. Valve is delivered with lever bracket, but lever itself must be ordered separately (see page 33).

\* The breakaway current refers to the current needed for the directional valve to open the connection "pump to work port". The final current is the lowest current needed to effect full actuation of a spool in the directional valve. This data must be taken into consideration when choosing control units, since the opening current of the control unit must be lower than the breakaway current of the spool actuator in order to avoid jerky starting and stopping. However, the control unit's final current must be higher than the final current of the directional valve in order to ensure that the spools can be fully actuated. This is important for the P70CF because, if the spool is not actuated fully, the free-flow gallery will not close, with the result that a certain amount of flow will go directly to tank.

**Connector Type [56]**

- A** AMP Junior-Timer type C
- D** Deutsch type OTOG-2S

See page 31

**Solenoid variant [59]**

**A027** The A027 spool actuator has the same data as the ECS, the difference being that the Solenoid valve in the A027 is equipped with both manual-override and air bleed functions. This option must be chosen in position [59] and with ECS or ECH in position [50].

**Remote controlled proportional spool actuators with closed spool end**

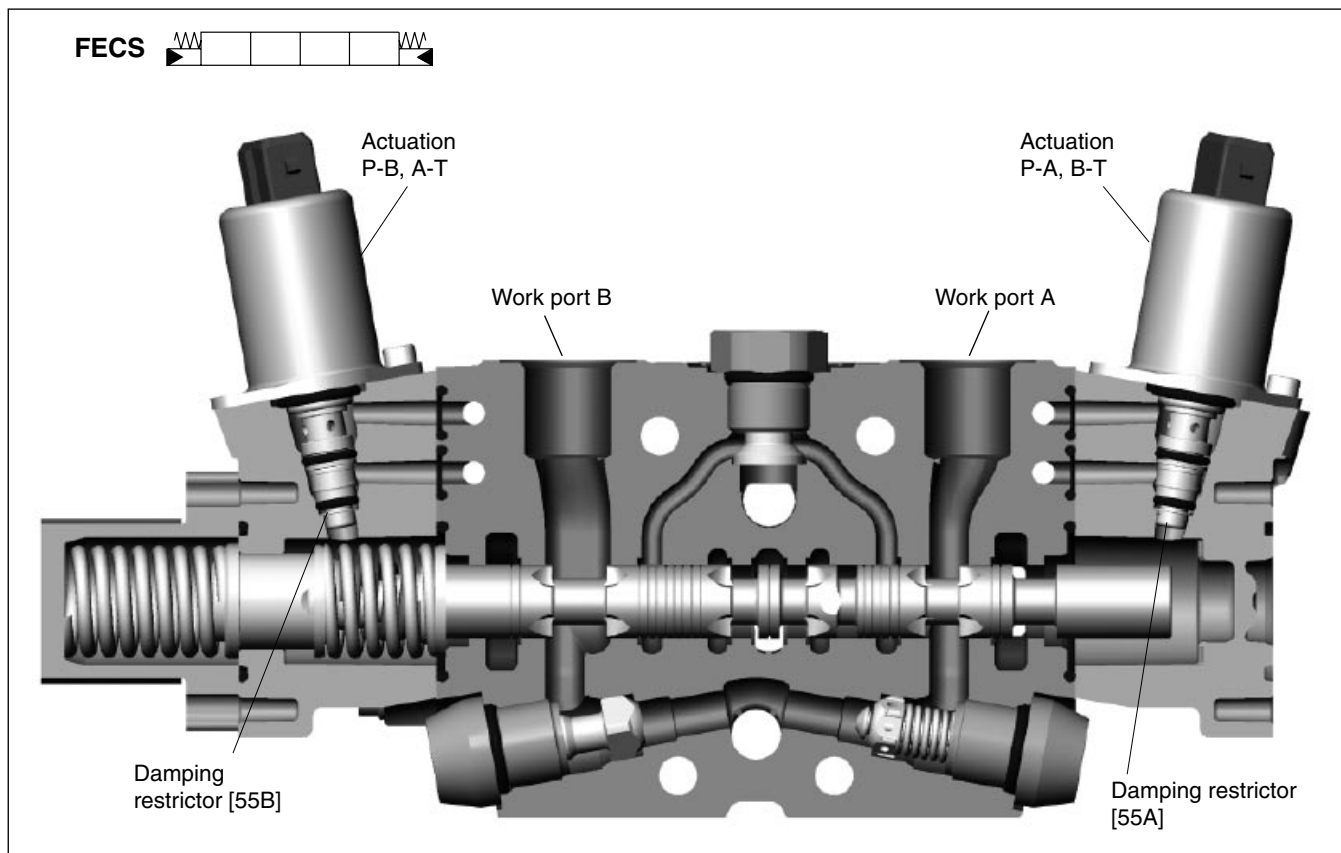

**FECS** Electro-hydraulic, proportionally controlled, spring-centered spool actuator with a fourth position for shifting the spool into the float position. The PS25 cartridge valve is used as its remote control valve.

**Valves with FECS have to be feeded with external pilot pressure in open centre systems (Not in CP/LS).**

The FECS spool actuator is best controlled by means of a Parker electric remote-control system (see separate brochure). The electrical connector must be ordered separately (see page 31).

Voltage	<b>12 V</b>	<b>24 V</b>
Breakaway current:*	max. 500 mA	max. 260 mA
Final current:*	min. 1010 mA	min. 510 mA
Float position current:	max. 1450 mA min. 1410 mA	max. 730 mA min. 690 mA
Solenoid (PS25):	max. 1450 mA 100% ED	max. 730 mA 100% ED
Coil resistance at +20 °C:	5.4 Ω	21.7 Ω
Inductance:	27.7 mH	7.0 mH
Tank pressure:	max. 15 bar	max. 15 bar

\* The breakaway current refers to the current needed for the directional valve to open the connection "pump to work port". The final current is the lowest current needed to effect full actuation of a spool in the directional valve. With the FECS spool actuator, the float position is obtained by further increasing the final current, see table. The foregoing data must be taken into consideration when choosing control units, since the opening current of the control unit must be lower than the breakaway current of the spool actuator in order to avoid jerky starting and stopping. However, the control unit's final current must be higher than the final current of the directional valve in order to ensure that the spools can be fully actuated. This is important for the P70CF because, if the spool is not actuated fully, the free-flow gallery will not close, with the result that a certain amount of flow will go directly to tank.

**Connector Type [56]**

- A** AMP Junior-Timer type C
  - D** Deutsch type OTOG-2S
- See page 31

**Spool position indicator [52]**

The spool actuators type C, C140 ECS and ECH can be equipped with an electric spool position indicator. It has one analog signal output linear, proportional to position of the spool between -1.5 and +1.5 mm of spool stroke according to the diagram below.

**SI** Spool position indicator (SSP2)

Connector must be ordered separately (see page 31)

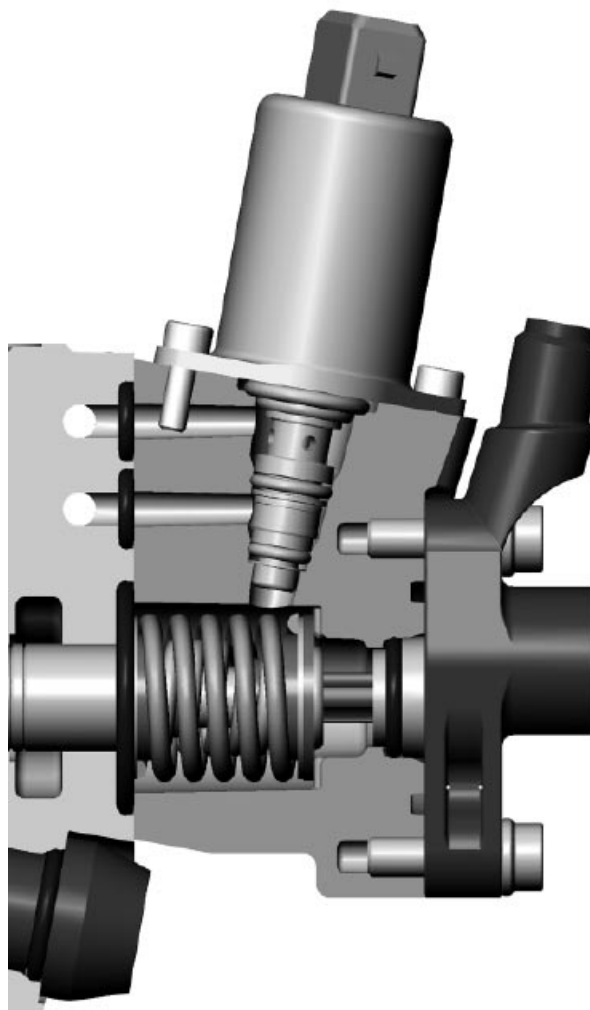
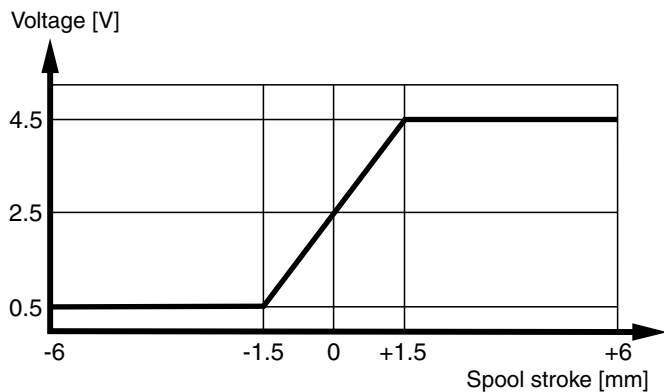

*ECS cap with spool position indicator (SSP2)*

The spool is the most important link between the actions of the operator and the movement of the controlled function. Parker therefore goes to great lengths to optimise spools for different flows, load conditions, functions and applications. Since this is a process of continuous development work, new spools are being introduced all the time. For this reason, the many different spools available are not detailed in this catalogue. Parker's computerised specification program will generate proposals for suitable spools for the application and functions of the hydraulic system in your machine.

**Spool function [60]**

Spools are divided into different groups, depending on their basic function.

- D** Double-acting spool. Blocked in the neutral position.
- EA** Single-acting spool. Blocked in the neutral position and work port B blocked.
- EB** Single-acting spool. Blocked in the neutral position and work port A blocked.
- M** Double-acting spool. Work ports connected to tank (float position) in neutral.
- F** Double-acting spool with fourth position in which both work ports are connected to tank (float position). Blocked in neutral position.
- CA** Regenerative spool for rapid feeding of a cylinder, or for flow saving. The large side of the cylinder is always connected to work port A.

Certain spools have been equipped with drainage from work port to tank when the spool is in neutral. Drainage (approx. 2 mm<sup>2</sup>) serves to prevent pressure build-up in the work port. Such drainage is used primarily in combination with different types of external overcentre valve. The spool designation is affected as follows: A lower-case letter is suffixed to the usual spool designation indicating function, e.g. the D-spool becomes a Da-spool to indicate drainage from service-port A to tank.

- a** Drainage of service-port A to tank
- b** Drainage of service-port B to tank
- m** Drainage of work ports A and B to tank

Please note that LS spools have a different coding system.

All LS spool have "ls" after the spool codes leading letter e.g. a double acting spool, normal code D, would become Dls and for a single acting spool, normal code EA, would become EAls.

For spool selection including drainage, the drainage letter is placed at the end of the code e.g. for a single acting spool with drainage from work port A, the code would be EAlsa.

**Spool designation [69]**

Each spool version is imprinted with an alphabetical code to facilitate identification during tuning or servicing in the field.

**Pressure gallery [66]**

- N** Load-hold check valve to prevent undesirable sinking of a heavy load while a light load is in operation. (Standard)

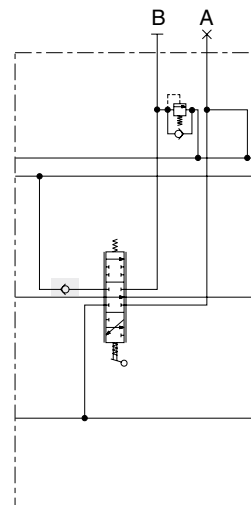
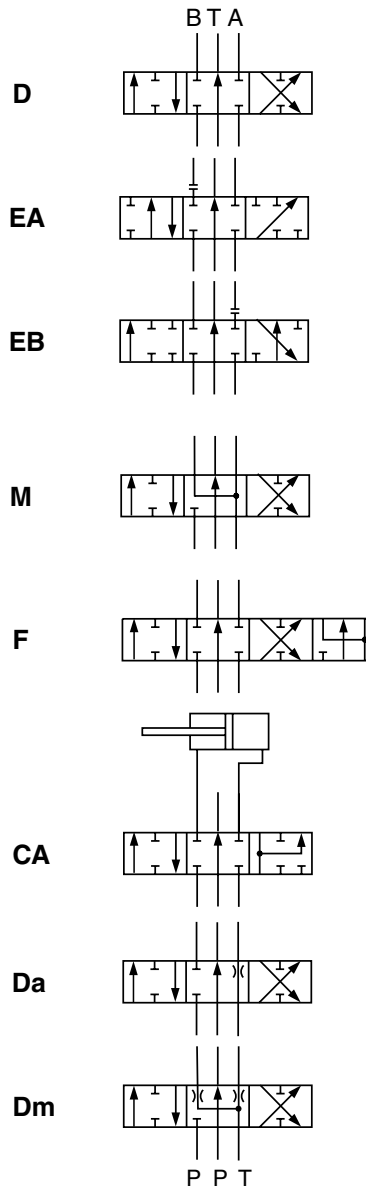

*Pressure gallery always fitted with check valve (N).*

**Pressure limiters in work ports [76A/B]  
 (Port relief valves)**

The work ports can be equipped with individual port-relief and/or anti-cavitation valves.

PLC cartridge valves are used as port relief valves. They are renowned for their long service life, tightness, fast opening sequence and good characteristics over the entire flow range.

**Port relief valve [76]**

- /** Hole for port relief valve not machined.
- X2** Work port connected with valve's tank gallery.
- Y2** Connection between work port and tank gallery blocked. (Cavity plug)
- N2** Anti-cavitation valve fitted. The anti-cavitation valve serves to ensure that, in the event of a lower pressure in the work port than in the tank, oil can be sucked from the system oil tank to the consumer. To improve the anti-cavitation function, the oil tank can be pressurised. Note that the counter pressure valve PT [33] does not influence the pressure in the anti-cavitation valve's tank line.
- PA** PLC combined port-relief and anti-cavitation valve fitted. Valve is factory-set at the specified pressure. Optional pressure settings: 50, 63, 80, 100, 125, 140, 160, 175, 190, 210, 230, 240, 250, 260, 280, 300, 320 and 350 bar.

Since the cavities for X2, Y2, N2 and PA have the same machining, it is easy to change the function of an existing valve.

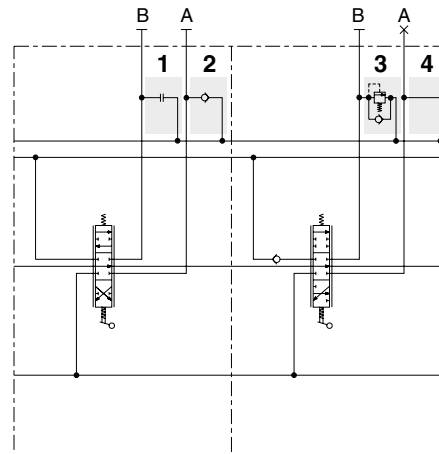

In the diagram above:

Section 1, work port B, is fitted with a Y2-plug (1) to block the connection to tank.

Section 1, work port A, is fitted with an anti-cavitation valve N2 (2).

Section 2, work port B, is equipped with a combined port-relief and anti-cavitation valve (3) to limit the pressure and prevent cavitation.

Section 2, work port A, is connected to tank - X2 variant - in the case of EB spools (4).

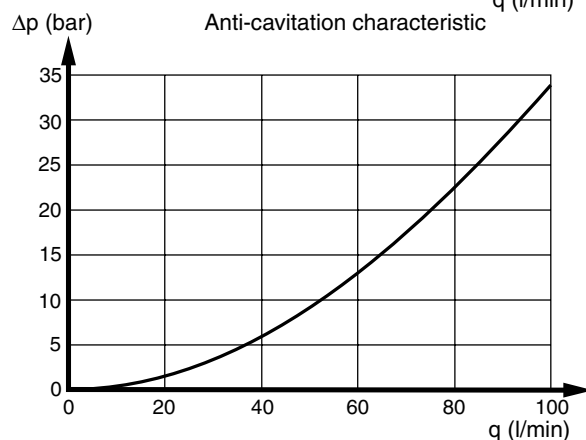
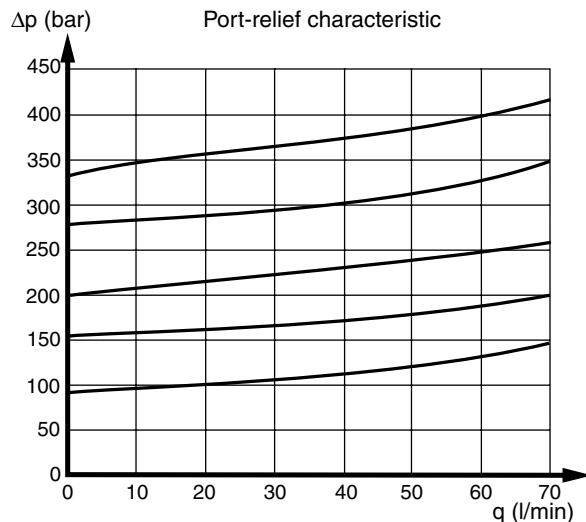

The curve shows the pressure drop between the tank connection and work port when port relief valve (PA) or anti-cavitation valve (N2) without port-relief function is used as an anti-cavitation valve.

**Function blocks (manifolds)**

P70 valves can be equipped with manifold-type function blocks that enable total system solutions to be integrated into the valve.

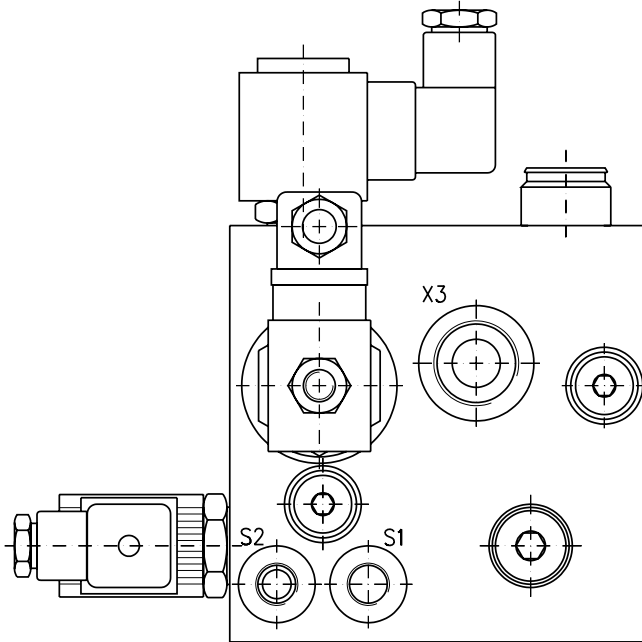

Please contact your Parker representative for more information about integral system solutions. In addition to standard function blocks, special function blocks can be designed by our experienced product and system designers to exactly meet your needs.

The function block above was specially adapted for a customer. Like most of our function blocks, it was constructed with the aid of cartridge valves. Only the housing itself is a unique component.

**Connectors**

Connectors are not included with spool actuators, and should be ordered separately as per the lists below or ordered from your local connector supplier.

**Spool actuators ECS, ECH, FECS and inlet section with pump-unloading**

Suitable connectors for option A in pos [56] are:  
 AMP Junior-Timer type C, 963040-3,  
 Bosch 1 928 402 404

Assembly kits complete with pins and seals can be ordered on following kit numbers:

1 off	<b>393000K822</b>
10 off	<b>393000K825</b>
50 off	<b>393000K826</b>
100 off	<b>393000K827</b>

Suitable connectors for option D in pos [56] are:  
 Deutsch type OTOG-2S

**Spool actuator ACE**

Suitable connector kit is:  
 Hirschman.

Complete connector sets can be ordered on following kit numbers:

1 off	<b>9125 9551 00</b>
10 off	<b>9125 9551 10</b>
25 off	<b>9125 9551 25</b>
50 off	<b>9125 9551 50</b>
100 off	<b>9125 9551 99</b>

**Spool position indicator SI**

Suitable connector is:  
 Binder Sensor connector Series 736 (M12x1) 3 contacts female.

**Hand levers**

Levers are not supplied with the valve and must therefore be ordered separately.

They are furnished with window-type knobs, so that machine builders can insert the appropriate function symbol beneath a transparent cap to indicate the function of the lever. Levers are supplied complete with mounting kits.

Lever:	Length L mm	Length L (inch)	Ordering No. 1 piece	Ordering No. 25 pieces
<b>MP1</b>	179	(7.05)	<b>8234 9390 21</b>	<b>8234 9390 21 25</b>
<b>MP3</b>	202	(7.95)	<b>8234 9390 23</b>	<b>8234 9390 23 25</b>
<b>MP6</b>	122	(4.80)	<b>8234 9390 26</b>	<b>8234 9390 26 25</b>
<b>MP11</b>	302	(11.89)	<b>8234 9390 31</b>	<b>8234 9390 31 25</b>
<b>MP12</b>	194	(7.95)	<b>8234 9390 32</b>	<b>8234 9390 32 25</b>
<b>MP8</b>	171	(9.84)	<b>8234 9390 28</b>	<b>8234 9390 28 25</b>
<b>MP13</b>	246	(9.69)	<b>8234 9390 33</b>	<b>8234 9390 33 25</b>
<b>MP14</b>	165	(6.50)	<b>8234 9390 34</b>	<b>8234 9390 34 25</b>
<b>MP15*</b>	165	(6.50)	<b>8234 9390 35</b>	<b>8234 9390 35 25</b>

\* Red knob

**Hand levers for open spool-actuators**

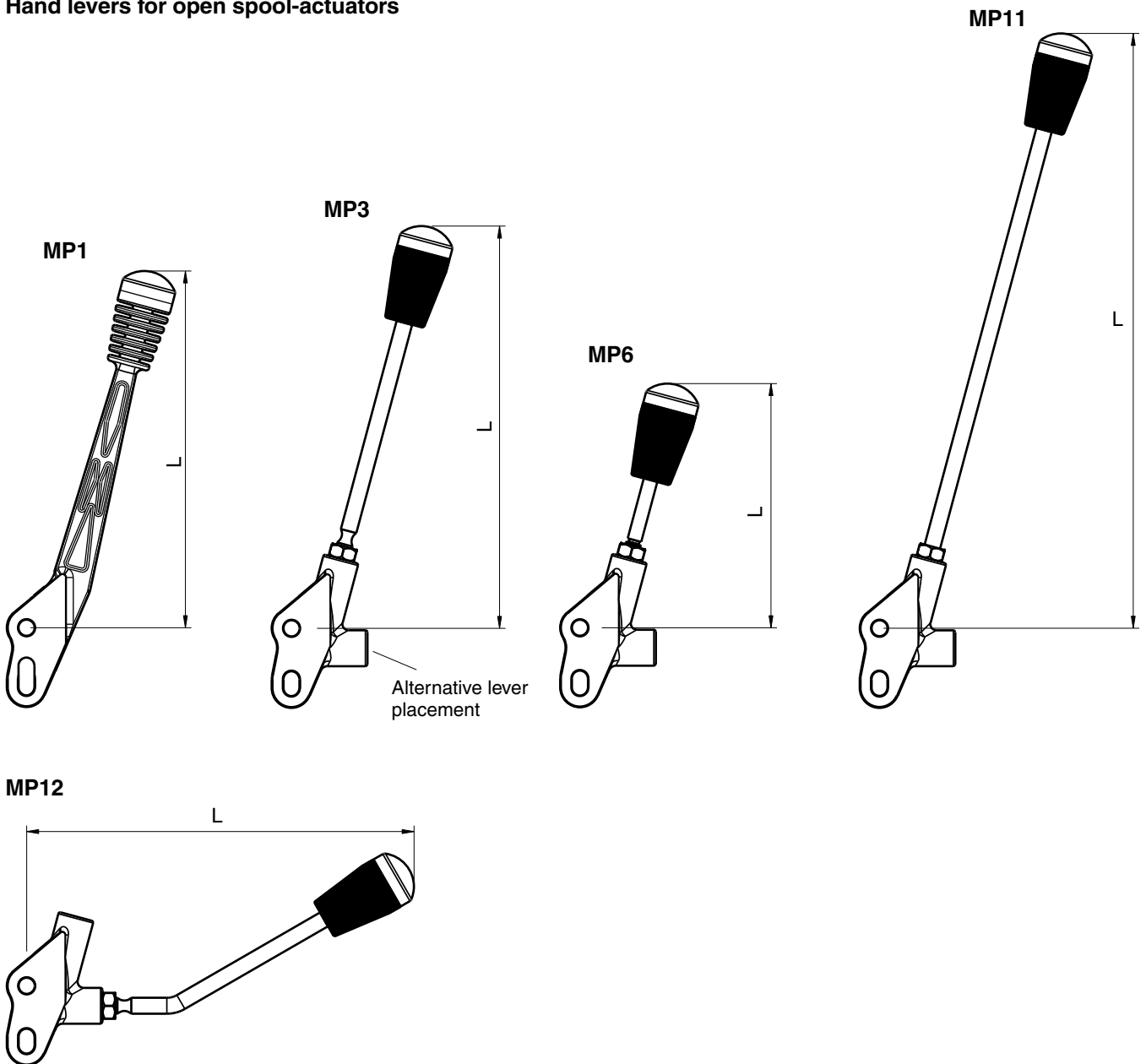



**Hand levers for mechanical co-ordinate control for open spool-actuators**

**MP8**

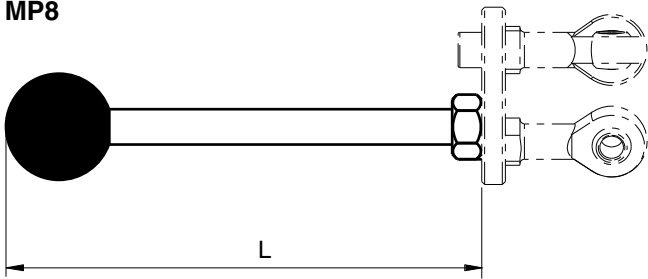

**Hand levers for closed spool-actuators**

**MP13**

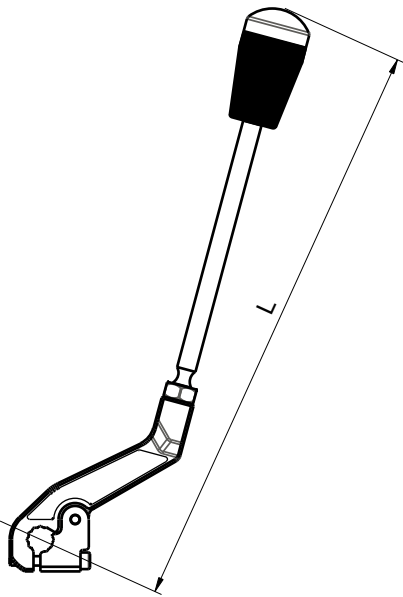

**MP14  
MP15**

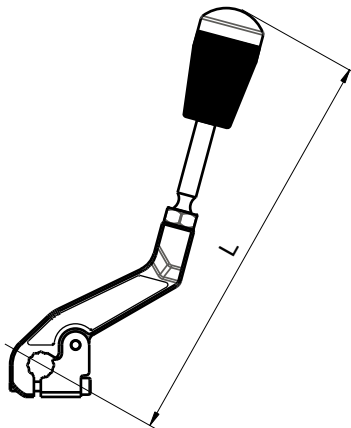

**Standard valve**

For connection dimensions, please see page 10.

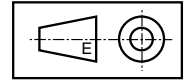

(inch)

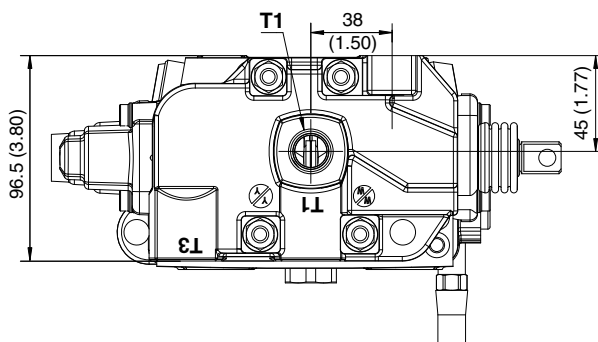
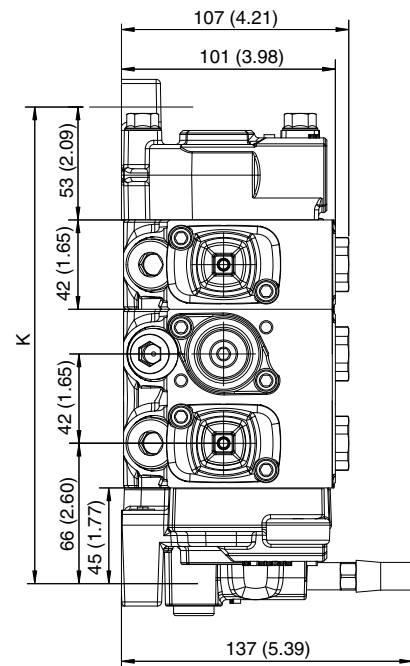
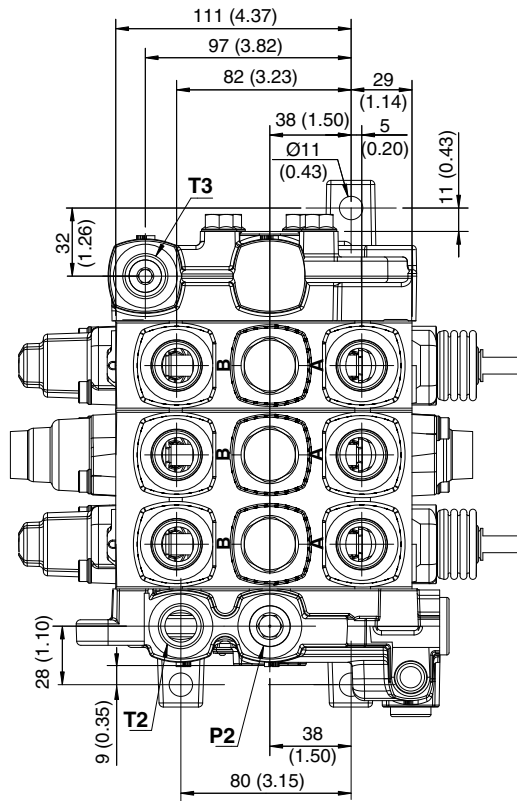
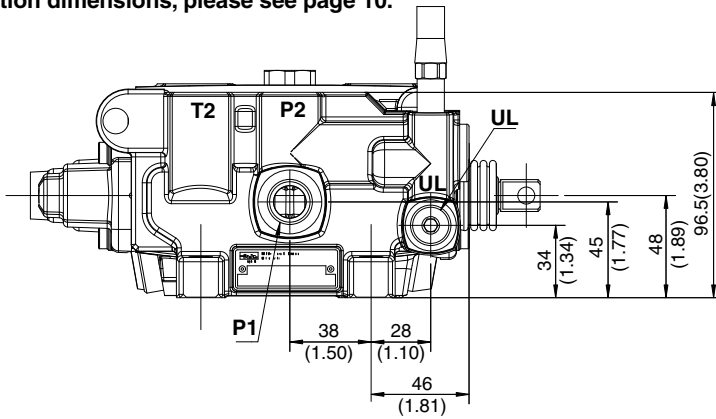

No. of sections	K mm	K inch
1	140	(5.51)
2	182	(7.17)
3	224	(8.82)
4	266	(10.47)
5	308	(12.13)
6	350	(13.78)
7	392	(15.43)
8	434	(17.09)
9	476	(18.74)
10	518	(20.39)

**Model with closed spool end**

For connection dimensions, please see page 10.

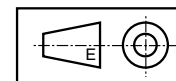

(inch)

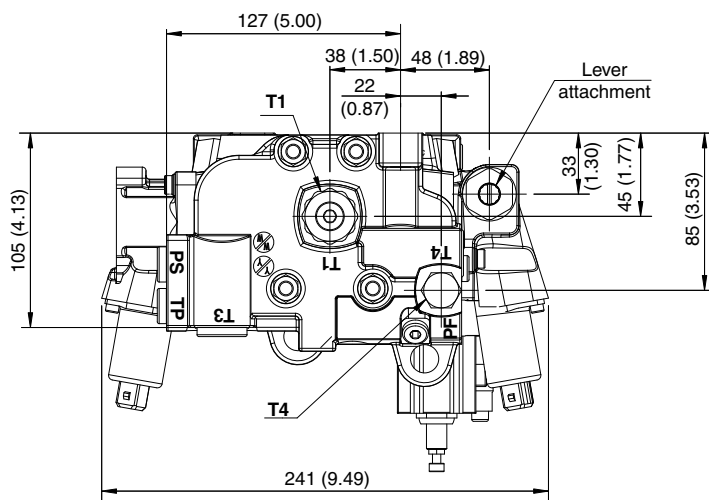
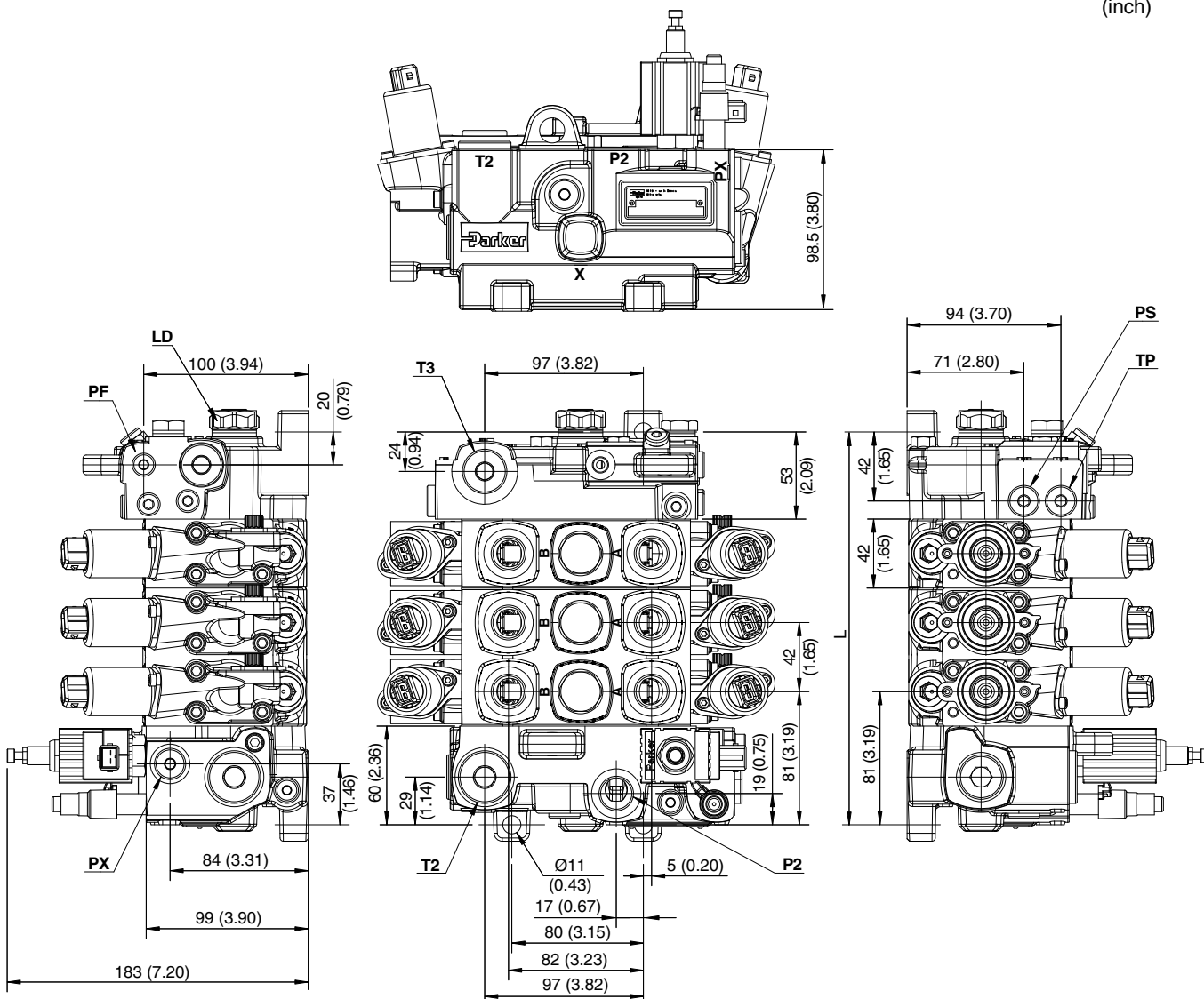

No. of sections	L mm	L inch
1	155	(6.10)
2	197	(7.76)
3	239	(9.41)
4	281	(11.06)
5	323	(12.72)
6	365	(14.37)
7	407	(16.02)
8	449	(17.68)
9	491	(19.33)
10	533	(20.98)

**Spool actuators**

(inch)

**LMB**

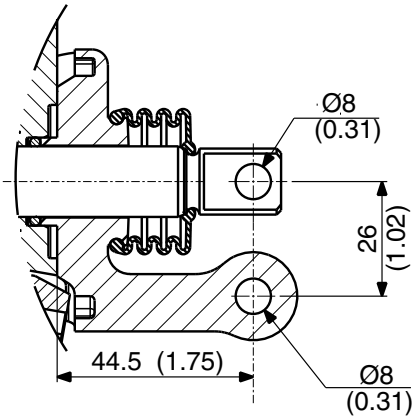

**LU**

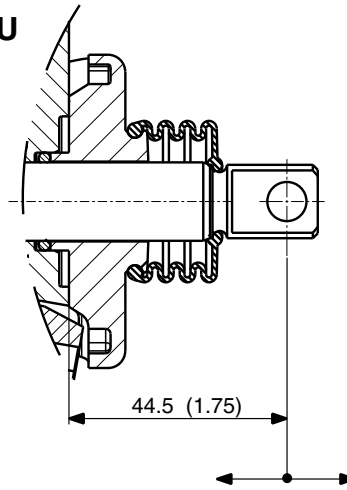

Spool stroke 12.5 mm (0.49) for spool function F [60]. Others 6.0 mm (0.24). Opens pump to work port A.

Spool stroke 6.0 mm (0.24); opens pump to work port B.

**C/C140**

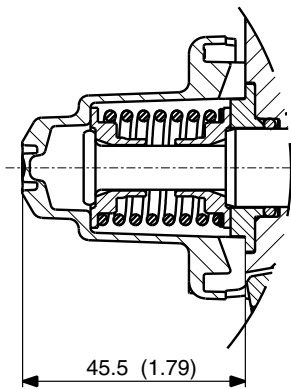

**B2C**

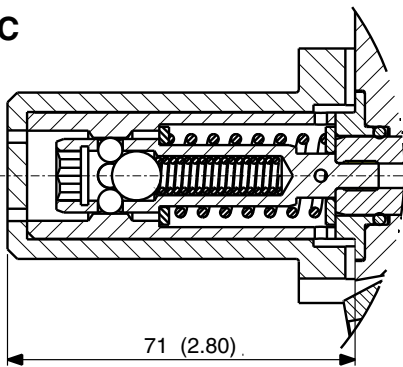

**CB**

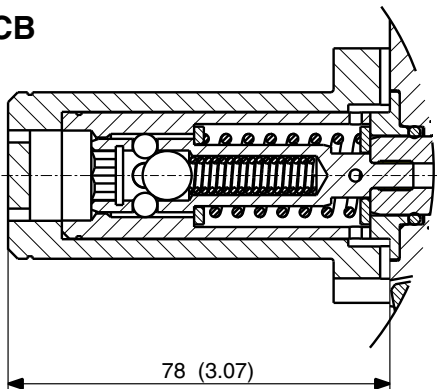

**Spool actuators**

(inch)

**ACE**

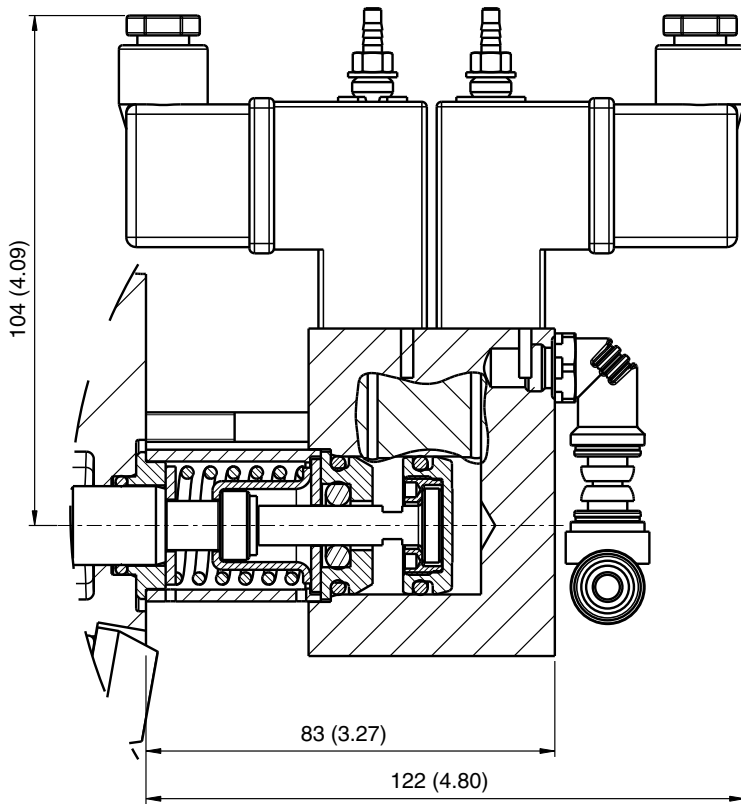

**ACP**

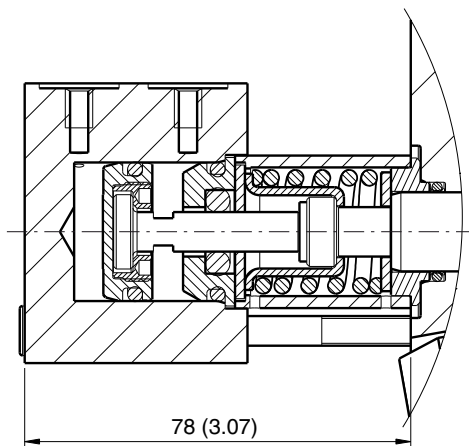

**Spool actuators**

(inch)

**ECS**  
**ECH**

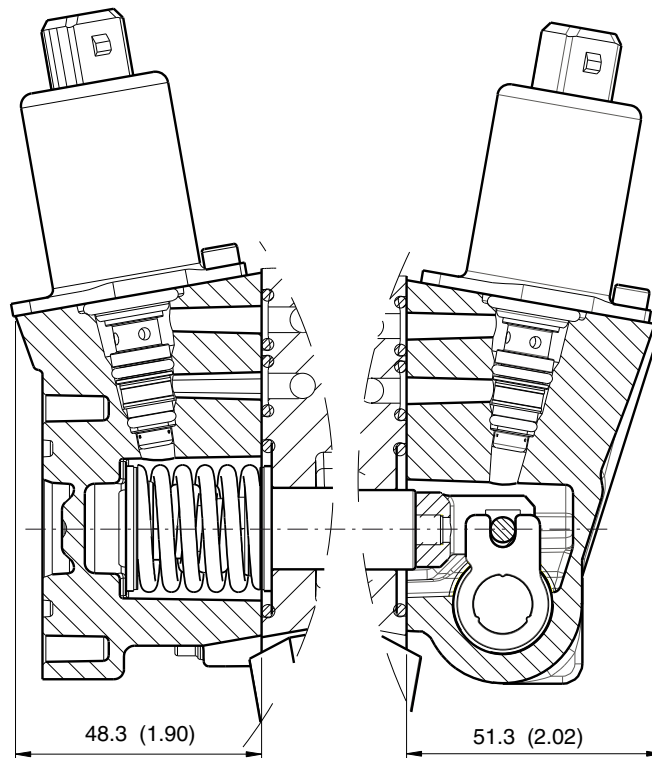

**PC**

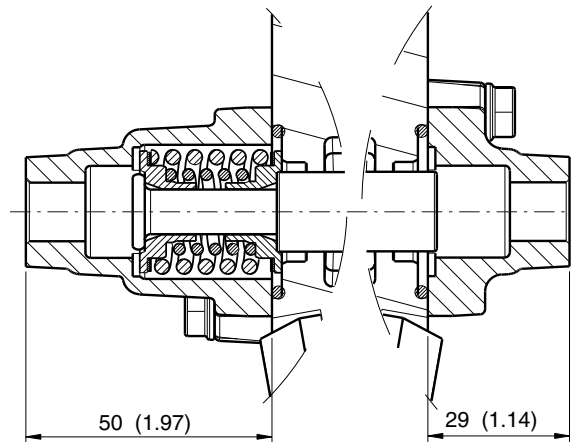

**FPC**

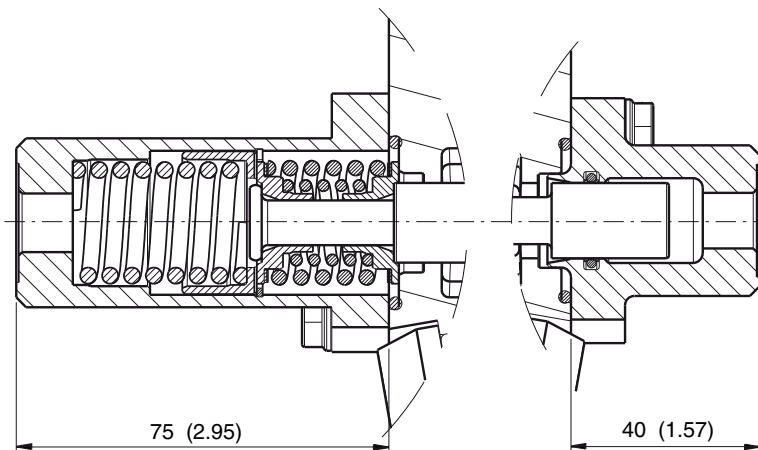



## **WARNING**

**FAILURE OR IMPROPER SELECTION OR IMPROPER USE OF THE PRODUCTS AND/OR SYSTEMS DESCRIBED HEREIN OR RELATED ITEMS CAN CAUSE DEATH, PERSONAL INJURY AND PROPERTY DAMAGE.**

This document and other information from Parker Hannifin Corporation, its subsidiaries and authorized distributors provide product and/or system options for further investigation by users having technical expertise. It is important that you analyze all aspects of your application, including consequences of any failure, and review the information concerning the product or system in the current product catalogue. Due to the variety of operating conditions and applications for these products or systems, the user, through its own analysis and testing, is solely responsible for making the final selection of the products and systems and assuring that all performance, safety and warning requirements of the application are met.

The products described herein, including without limitation, product features, specifications, designs, availability and pricing, are subject to change by Parker Hannifin Corporation and its subsidiaries at any time without notice.

## **Offer of Sale**

Please contact your Parker representation for a detailed "Offer of Sale".

# Hydraulics Group Sales Offices

## Europe

### **Austria**

#### **Wiener Neustadt**

Tel: +43 (0)2622 23501  
Fax: +43 (0)2622 66212

### **Austria**

#### **Wiener Neustadt**

#### **(Resp for East Europe)**

Tel: +43 (0)2622 23501-970  
Fax: +43 (0)2622 23501-977

### **Belgium**

#### **Nivelles**

Tel: +32 (0)67 280 900  
Fax: +32 (0)67 280 999

### **Czech Republic**

#### **Klecany**

Tel: +420 284 083 111  
Fax: +420 284 083 112

### **Denmark**

#### **Ballerup**

Tel: +45 4356 0400  
Fax: +45 4373 3107

### **Finland**

#### **Vantaa**

Tel: +358 20 753 2500  
Fax: +358 20 753 2200

### **France**

#### **Contamine-sur-Arve**

Tel: +33 (0)450 25 80 25  
Fax: +33 (0)450 25 24 25

### **Germany**

#### **Kaarst**

Tel: +49 (0)2131 4016 0  
Fax: +49 (0)2131 4016 9199

### **Ireland**

#### **Dublin**

Tel: +353 (0)1 466 6370  
Fax: +353 (0)1 466 6376

### **Italy**

#### **Corsico (MI)**

Tel: +39 02 45 19 21  
Fax: +39 02 4 47 93 40

### **The Netherlands**

#### **Oldenzaal**

Tel: +31 (0)541 585000  
Fax: +31 (0)541 585459

### **Norway**

#### **Ski**

Tel: +47 64 91 10 00  
Fax: +47 64 91 10 90

### **Poland**

#### **Warsaw**

Tel: +48 (0)22 573 24 00  
Fax: +48 (0)22 573 24 03

### **Portugal**

#### **Leca da Palmeira**

Tel: +351 22 9997 360  
Fax: +351 22 9961 527

### **Slovakia**

#### **Ref. Czech Republic**

### **Spain**

#### **Madrid**

Tel: +34 91 675 73 00  
Fax: +34 91 675 77 11

### **Sweden**

#### **Spånga**

Tel: +46 (0)8 597 950 00  
Fax: +46 (0)8 597 951 10

### **United Kingdom**

#### **Warwick**

Tel: +44 (0)1926 317 878  
Fax: +44 (0)1926 317 855

## International

### **Australia**

#### **Castle Hill**

Tel: +61 (0)2-9634 7777  
Fax: +61 (0)2-9842 5111

### **Canada**

#### **Milton, Ontario**

Tel: +1 905-693-3000  
Fax: +1 905-876-0788

### **China**

#### **Shanghai**

Tel: +86 21 5031 2525  
Fax: +86 21 5834 8975

### **Asia Pacific Group**

#### **Hong Kong**

Tel: +852 2428 8008  
Fax: +852 2425 6896

### **India**

#### **Mumbai**

Tel: +91 22 5613 7081/82-85  
Fax: +91 22 2768 6841/6618

### **Japan**

#### **Tokyo**

Tel: +(81) 3 6408 3900  
Fax: +(81) 3 5449 7201

### **Latin America Group**

#### **Brazil**

Tel: +55 51 3470 9144  
Fax: +55 51 3470 9281

### **South Africa**

#### **Kempton Park**

Tel: +27 (0)11-961 0700  
Fax: +27 (0)11-392 7213

### **USA**

#### **Cleveland (industrial)**

Tel: +1 216-896-3000  
Fax: +1 216-896-4031

#### **Lincolnshire (mobile)**

Tel: +1 847-821-1500  
Fax: +1 847-821-7600

**Parker Hannifin is the world's premier supplier of motion and control systems and solutions, with sales and manufacturing facilities throughout the world. For product information and details of your nearest Parker sales office, visit us at [www.parker.com](http://www.parker.com) or call free on 00800 2727 5374.**



Catalogue HY17-8546/UK  
2M 01/2007 RT

© Copyright 2007  
Parker Hannifin Corporation  
All rights reserved.